

CATALOG · CATALOGO · CATALOGUE

CATÁLOGO

v20251031



 **MR**
ASSA ABLOY

www.mr.pt

Experience a safer
and more open world

www.mr.pt

CATALOG · CATALOGO · CATALOGUE

CATÁLOGO



ASSA ABLOY

06-07

MR | ASSA ABLOY: QUEM SOMOS

ABOUT US · SOBRE NOSOTROS · À PROPOS DE NOUS

08-13

SISTEMAS ANTIPÂNICO

ANTIPANIC SYSTEMS · SISTEMAS ANTIPÁNICO · SYSTÈMES ANTI-PANIQUE

14-25

OSCILOBATENTE

TILT AND TURN · OSCILOBATIENTE · OSCILLO-BATTANT

26-45

LINHA QUAD

QUAD LINE · LÍNEA QUAD · LIGNE QUAD

46-57

LINHA MONDIAL

MONDIAL LINE · LÍNEA MONDIAL · LIGNE MONDIAL

58-73

LINHA PRESTIGE

PRESTIGE LINE · LÍNEA PRESTIGE · LIGNE PRESTIGE

74-83

LINHA MR

MR LINE · LÍNEA MR · LIGNE MR

84-93

KITS E FECHOS

KITS AND LOCKS · KITS Y CIERRES · KITS ET LOQUETEUX

94-99

COMPASSOS E FECHOS

STAYS AND ITS LOCKING · COMPASES Y CIERRES · COMPAS ET VERROUILLAGE

100-115

DOBRADIÇAS

HINGES · BISAGRAS · PAUMELLES

116-129

SISTEMA ELEVÁVEL

LIFT & SLIDE · CORREDEIRA ELEVABLE · COULISSANT ELEVABLE

130-145

SISTEMAS DE CORRER

SLIDING SYSTEMS · SISTEMAS DE CORRER · SYSTÈME COULISSANT

146-157

ASAS E PUXADORES DE PORTA

HANDLES AND DOOR HANDLES · ASAS Y TIRADORES DE PUERTA
POIGNÉES ET POIGNÉES DE PORTE

158-161

PUXADORES CORTA-FOGO

FIRESTOP DOOR HANDLES · MANILLAS PARA PUERTAS CORTA-FUEGO
POIGNÉE COUPE FEU

162-167

DIVERSOS MR

DIVERSE · DIVERSOS · DIVERS

168-211

FECHADURAS

LOCKS · CERRADURAS · SERRURES

212-223

CILINDROS

CYLINDERS · CYLINDRES · ZYLINDER

224-225

ASSA ABLOY: APRESENTAÇÃO

PRESENTATION · PRESENTACIÓN · PRÉSENTATION

O conteúdo dos desenhos técnicos é apenas informativo.
A mecanização e instalação são feitas com total responsabilidade do instalador.
The contents of the drawings technicians is only informative.
Mechanization and installation are made with full responsibility of the installer.



ASSA ABLOY

26-45

QUAD

46-57

MONDIAL

58-73

PRESTIGE

74-83

MR



www.mr.pt

UMA VISÃO CLARA FOCADA NA INOVAÇÃO

A CLEAR VISION FOCUSED ON INNOVATION

PASSADO E PRESENTE

A MR ASSA ABLOY é o principal fabricante português na produção de ferragens e acessórios para sistemas de alumínio.

Fundada em 1975, a MR iniciou a sua atividade, com cerca de 10 colaboradores, no fabrico de ferragens tradicionais para serralharia de ferro e mobiliário de madeira.

No final dos anos 80, a MR foi pioneira em Portugal ao especializar-se na produção de ferragens e acessórios para janelas e portas de alumínio, tendo consolidado, ao longo dos anos, a sua posição de liderança no mercado nacional.

Em 2021, a MR integrou o grupo ASSA ABLOY.

Com sede e instalações industriais na cidade de Águeda, no centro de Portugal, a MR ASSA ABLOY emprega mais de 160 colaboradores e desenvolve a sua atividade comercial, a nível global, em mais de 40 países.

PRODUTOS E INOVAÇÃO

Graças ao forte investimento em R&D e ao constante acompanhamento das principais tendências do mercado, a MR ASSA ABLOY conta com uma extensa gama produtos que permite responder às necessidades dos clientes através do fornecimento de soluções completas.

- Soluções para portas e janelas em alumínio e pvc;
- Soluções para janelas de abrir e de correr;
- Fechaduras monoponto e multiponto para portas de comunicação e segurança;
- Puxadores, dobradiças e acessórios em inox e alumínio.



THE PAST & TODAY

MR ASSA ABLOY is the Portuguese leading manufacturer of hardware and accessories for aluminum systems.

Founded in 1975, MR began its activities with about 10 employees in the production of traditional hardware for ironmongery and wooden furniture.

In the late 1980s, MR was a pioneer in Portugal by specializing in the production of hardware and accessories for aluminum windows and doors, having consolidated, over the years, its leading position in the Portuguese market.

In 2021, MR became part of the ASSA ABLOY Group.

With headquarters and industrial facilities in the city of Águeda, in the center of Portugal, MR ASSA ABLOY has more than 160 employees and develops its commercial and sales operations globally in more than 40 countries.

PRODUCTS & INNOVATION

Thanks to the continued high investment in R&D and the constant follow-up of key market trends, MR ASSA ABLOY has a wide range of products to effectively meet customer needs by offering complete hardware solutions.

- Solutions for aluminum and pvc doors and windows;
- Solutions for casement and sliding windows;
- Single-point and multi-point locks for communication and security doors;
- Handles, hinges and accessories in stainless steel and aluminum.



ASSA ABLOY



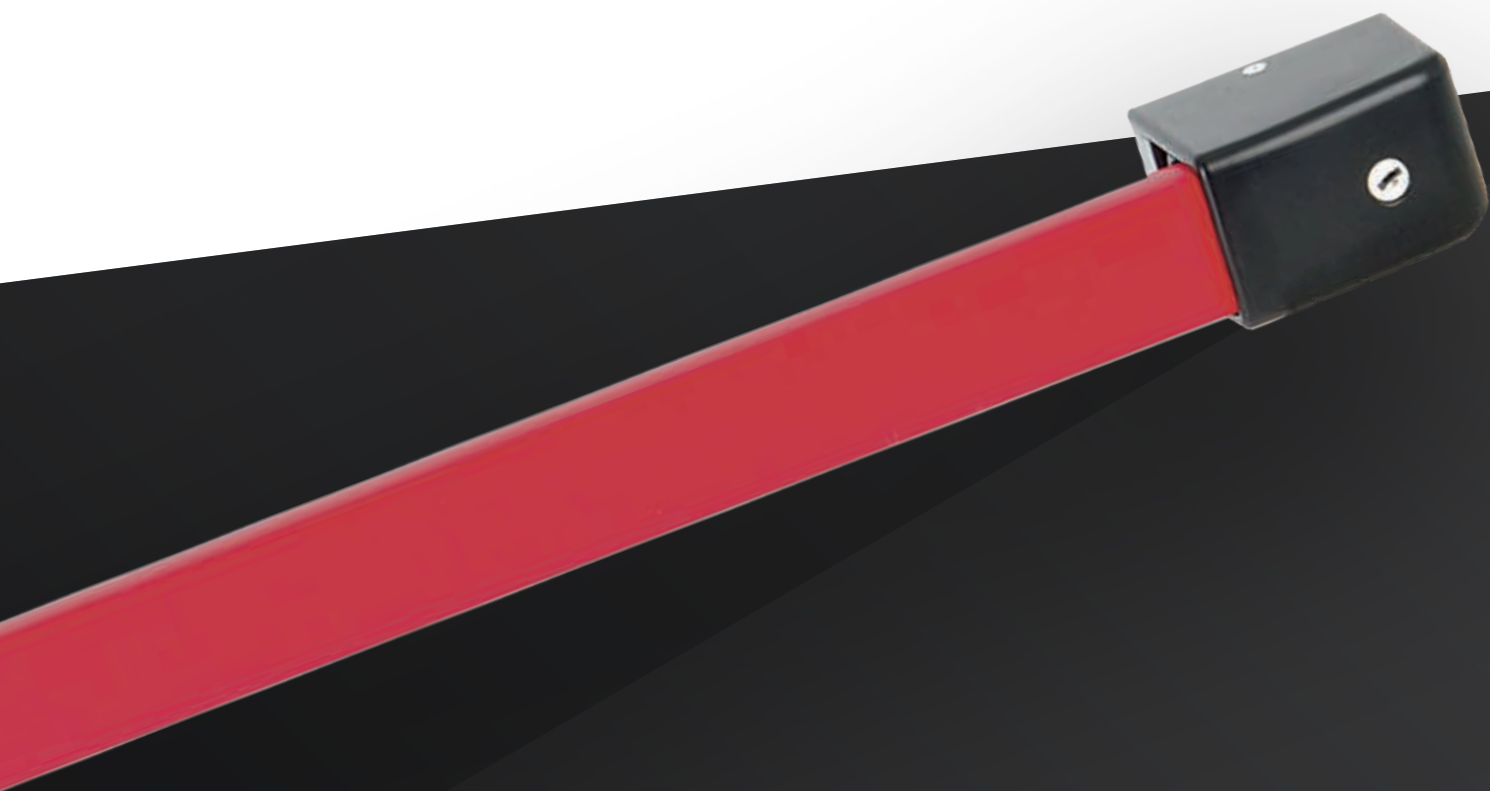

SISTEMAS ANTIPÂNICO

ANTIPANIC SYSTEMS

SISTEMAS ANTIPÁNICO

SYSTÈMES ANTI-PANIQUE

ESCAPE 1



EMBALAGEM - PACKAGING
EMPAQUETADO - EMBALLAGE

1 unidade por caixa
 1 unit per box
 1 unidade por caja
 1 unité par boîte

MATERIAIS - MATERIALS
MATERIALES - MATERIAUX

Alumínio - Zamak - Inox
 Aluminium - Zamak - Stainless steel
 Aluminio - Zamak - Acero inox
 Aluminium - Zamak - Inox

FIXAÇÃO - FIXING
FIJACIÓN - FIXATION

Parafusos incluídos
 Screws included
 Tornillos incluidos
 Vis inclus

ACABAMENTO - FINISHING
ACABADOS - FINITION

Lacado
 Powder painting
 Lacado
 Laqué

NORMA - STANDARD
NORMA - NORME

EN 1125

 0333



JOLLY

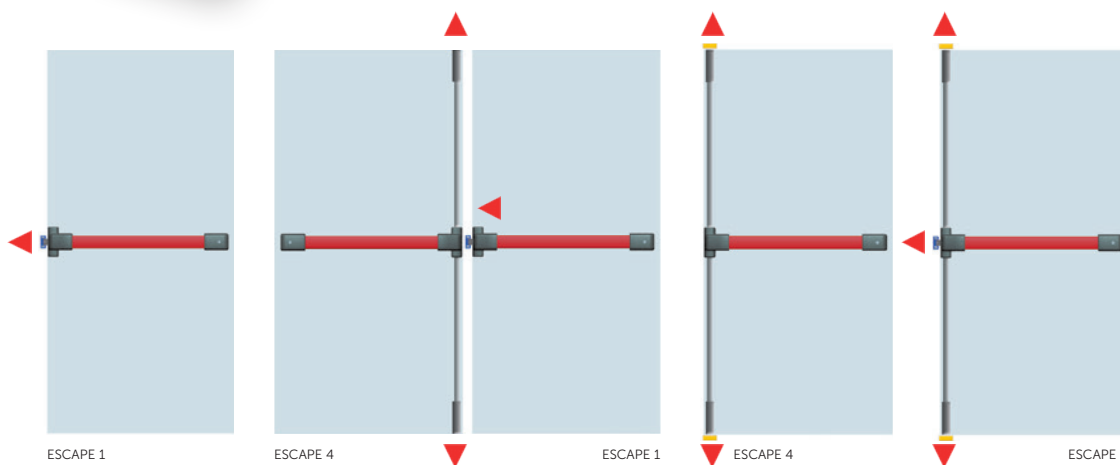

ESCAPE 1

ESCAPE 4

ESCAPE 1

ESCAPE 4

ESCAPE 3

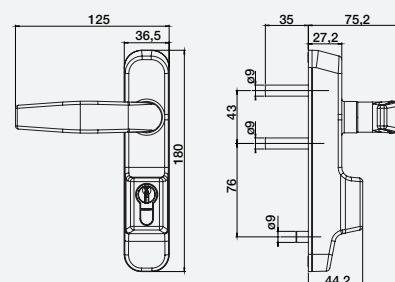
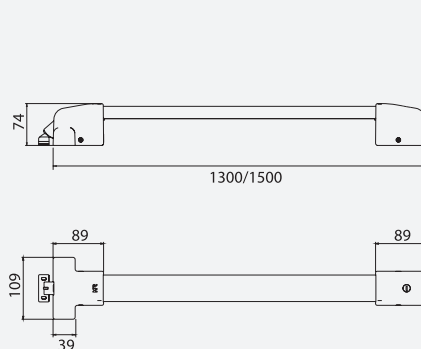
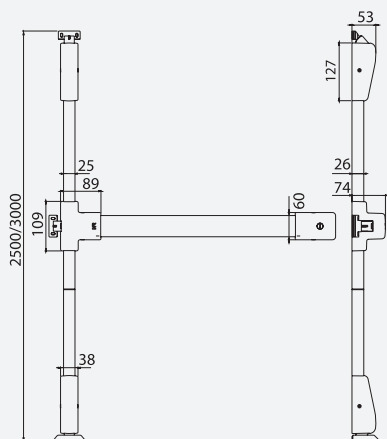

ESCAPE 5
 MODULAR / PUSH BAR

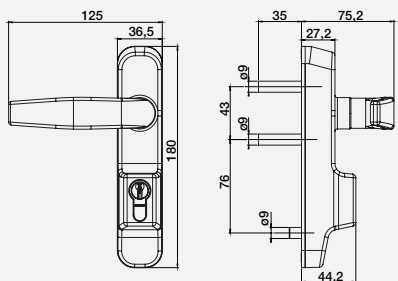
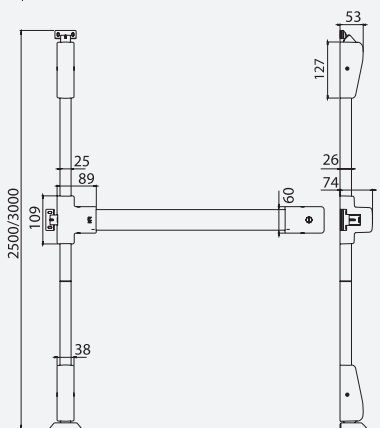
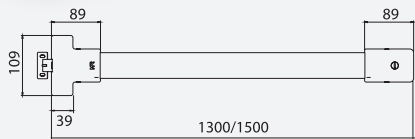

JOLLY



EMBALAGEM - PACKAGING
EMPAQUETADO - EMBALLAGE

1 unidade por caixa
 1 unit per box
 1 unidade por caja
 1 unité par boîte

ACABAMENTO - FINISHING
ACABADOS - FINITION

Lacado
 Powder painting
 Lacado
 Laqué

MATERIAIS - MATERIALS
MATERIALES - MATERIAUX

Alumínio - Zamak - Inox
 Aluminium - Zamak - Stainless steel
 Aluminio - Zamak - Acero inox
 Aluminium - Zamak - Inox

NORMA - STANDARD
NORMA - NORME

EN 1125



FIXAÇÃO - FIXING
FIJACIÓN - FIXATION

Parafusos incluídos
 Screws included
 Tornillos incluidos
 Vis inclus

PEÇAS · PARTS
PIEZAS · PIECES DE RECHANGE

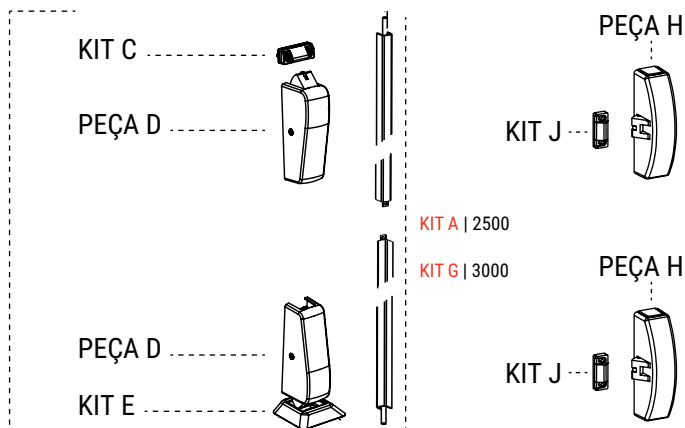
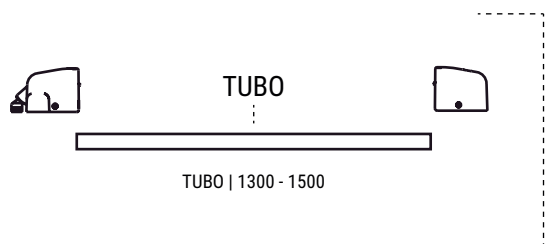

ESCAPE 10

MODULAR / CROSS BAR



JOLLY

**EMBALAGEM - PACKAGING
EMPAQUETADO - EMBALLAGE**

1 unidade por caixa
1 unit per box
1 unidade por caja
1 unité par boîte

**ACABAMENTO - FINISHING
ACABADOS - FINITION**

Lacado
Powder painting
Lacado
Laqué

**MATERIAIS - MATERIALS
MATERIALES - MATERIAUX**

Alumínio - Zamak - Inox
Aluminium - Zamak - Stainless steel
Aluminio - Zamak - Acero inox
Aluminium - Zamak - Inox

**NORMA - STANDARD
NORMA - NORME**

EN 1125



**FIXAÇÃO - FIXING
FIJACIÓN - FIXATION**

Parafusos incluídos
Screws included
Tornillos incluidos
Vis inclus

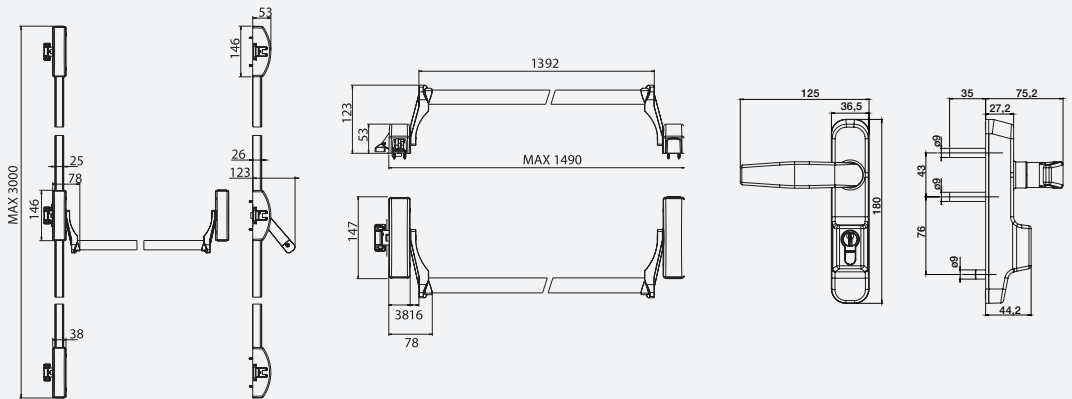

PEÇAS · PARTS
PIEZAS · PIECES DE RECHANGE

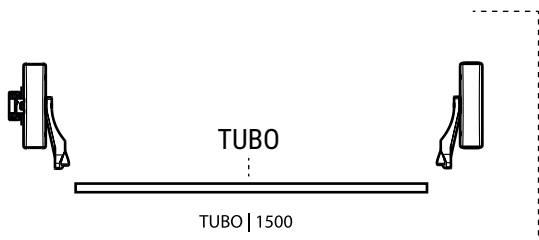

KIT C

PEÇA D

PEÇA D

KIT E

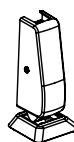

KIT A | 2500

KIT G | 3000

PEÇA H

KIT J

PEÇA H

KIT J



ESCAPE 5 / ESCAPE 10

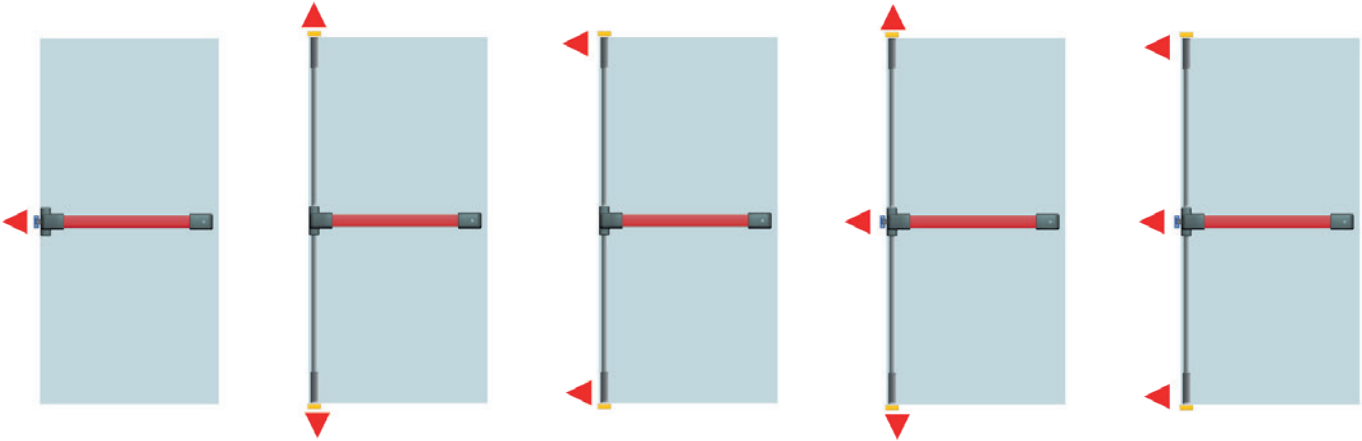

ESCAPE 5; 10

ESCAPE 5; 10

ESCAPE 5; 10

ESCAPE 5; 10

ESCAPE 5; 10

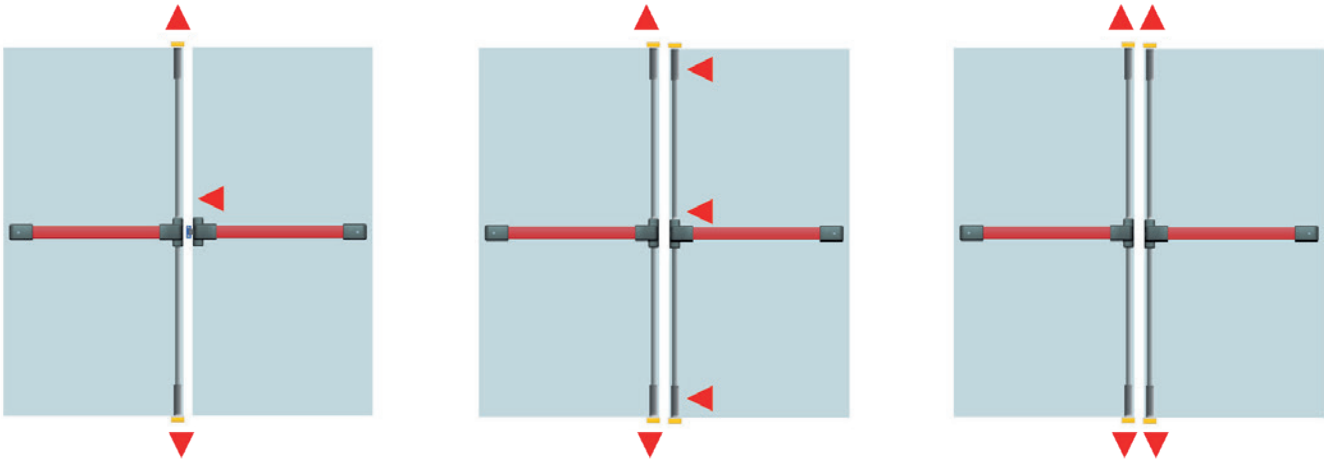

ESCAPE 5; 10

ESCAPE 5; 10

ESCAPE 5; 10

ESCAPE 5; 10

* ESCAPE 5; 10

* ESCAPE 5; 10

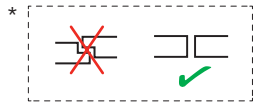



ASSA ABLOY



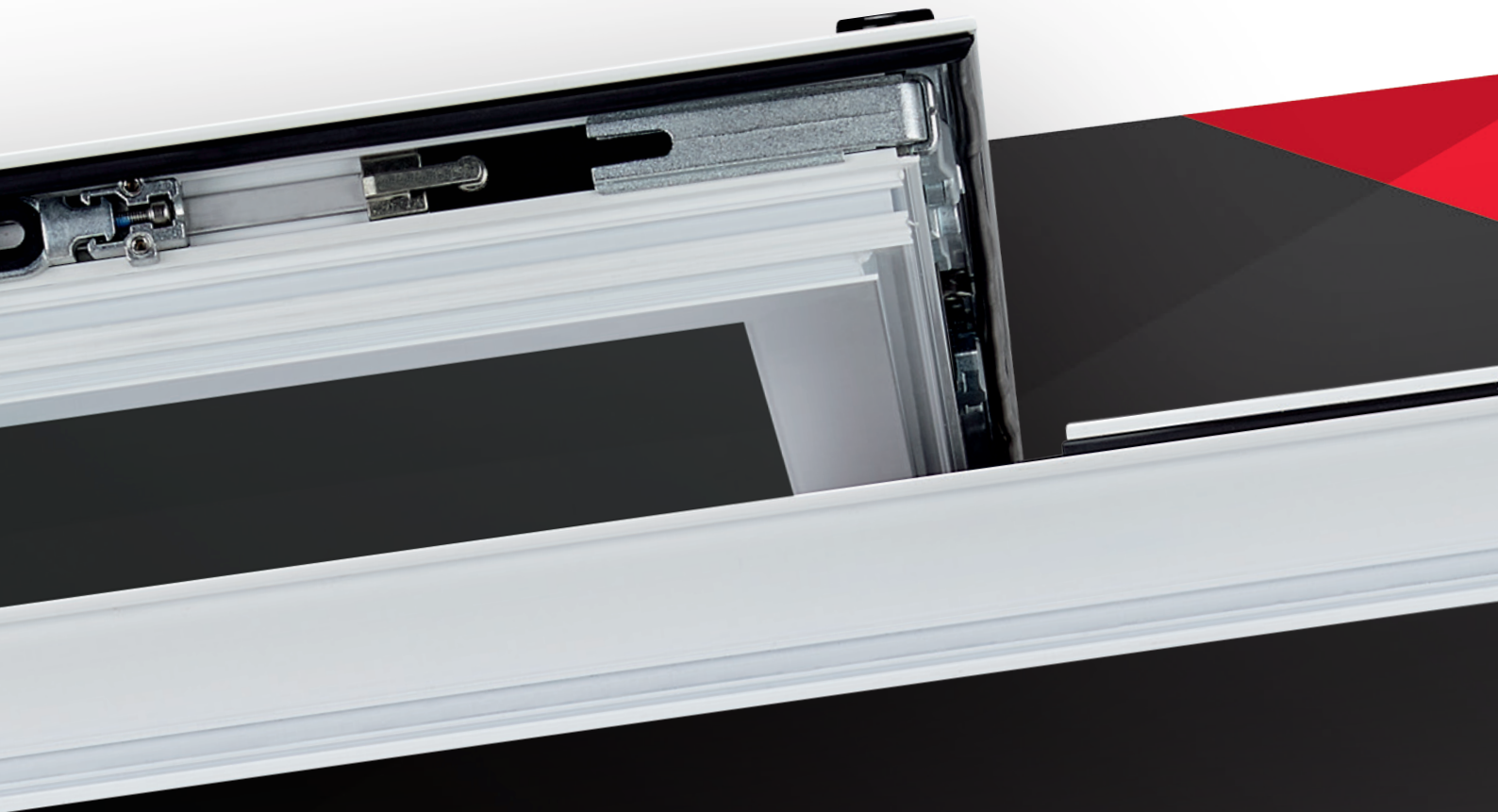

OSCILOBATENTES

TILT AND TURN

OSCILOBATIENTE

OSCILLO-BATTANT

M100
M100 C/C
5100 (Lac.)
5100 C/C
7000
9590
9590 C/C
9590 P



AFINAÇÃO ARO FIXO
 FIXED ARM SETTING
 AFINACIÓN ARO FIJO
 REGLAGE DE BRAS FIXE



M100

5100

7000

9590

OPÇÕES · OPTIONS
OPCIONES · OPTIONS

KIT VERTICAL
 KIT HORIZONTAL
 COMPASSO ADICIONAL
 OB 09701/ 09707 P. FECHO COM AF
 OB 1013 SUPLEMENTO P. FECHO
 MICRO
 COMPASSO MINI 34/45
 COMPASSO 38/55
 COMPASSO 55/90
 COMPASSO 90/120

NORMA - STANDARD
NORMA - NORME

EN 13126

M101
M101 C/C
5101 (Lac.)
5101 C/C
9591
9591 C/C
9591 P

AM



OPÇÕES · OPTIONS
OPCIONES · OPTIONS

KIT VERTICAL
COMPASSO ADICIONAL
OB 09701/ 09707 P. FECHO COM AF
OB 1013 SUPLEMENTO P. FECHO
MICRO
COMPASSO MINI 34/45
COMPASSO 38/55
COMPASSO 55/90
COMPASSO 90/120

NORMA · STANDARD
NORMA · NORME
EN 13126

AL - ABERTURA LÓGICA

9592 C/C



OPÇÕES · OPTIONS
OPCIONES · OPTIONS

KIT VERTICAL
COMPASSO ADICIONAL
OB 09701/ 09707 P. FECHO COM AF
OB 1013 SUPLEMENTO P. FECHO
MICRO
COMPASSO 38/55 AL
COMPASSO 55/90 AL
COMPASSO 90/120 AL

NORMA - STANDARD
NORMA - NORME

EN 13126

2ª FOLHA



COMPLEMENTOS · COMPLEMENTS · COMPLEMENTOS · COMPLÉMENTS

REF.ª	DESIGNAÇÃO	EMB.
9203	FECHOS ALUMÍNIO	24 cj
9204	FECHOS ZAMAK	12 cj
9205	KIT DOBRADIÇAS + FECHOS ZAMAK	4 cj
9206	KIT DOBRADIÇAS C/ AFINAÇÃO + FECHOS ZAMAK	4 cj
9207	DOBRADIÇAS 2ª FOLHA	6 cj
9210	DOBRADIÇA 2ª FOLHA C/ AFINAÇÃO	6 cj
9212	BIDIRECCIONAL	24 un.
9213	BIDIRECCIONAL	AM/ AL 24 un.

NORMA - STANDARD
NORMA - NORME
EN 13126

OPÇÕES · KIT



OPÇÕES / KITS

DESIGNAÇÃO	EMB.
KIT VERTICAL	12 un.
KIT HORIZONTAL	12 un.
COMPASSO ADICIONAL	12 un.
OB 09701/009707 P. FECHO COM AF	200 un.
MICRO	150 un.
MR 9208 - AJUSTADOR INVISÍVEL MR 9208	100 un.
MR 9209 - PONTO FECHO 2ª FOLHA C/ AFINAÇÃO MR 9209	100 un.
SUPLEMENTO OBO 1013	200 un.
CALÇO DE APOIO	200 un.

NORMA - STANDARD
NORMA - NORME
 EN 13126

SISTEMA OCULTO

CONCEALED TILT AND TURN SYSTEM
SISTEMA OSЦИLOBATENTE OCULTO
SYSTÈME CACHÉ OSЦИLOBATENTE



DOBRADIÇA INFERIOR
LOWER HINGED HINGE
DOBLADIACIÓN INFERIOR
CHARNIÈRE INFÉRIEURE



ESTILO MINIMALISTA
MINIMALIST STYLE
ESTILO MINIMALISTA
STYLE MINIMALISTE



REGULAÇÃO EM 3D
3D ADJUSTMENT
REGULACIÓN EN 3D
AJUSTEMENT 3D



ABERTURA ATÉ 180°
OPENING UP TO 180°
APERTURA HASTA 180°
OUVERTURE JUSQU'À 180°



INSTALAÇÃO FÁCIL
EASY INSTALLATION
INSTALACIÓN FÁCIL
INSTALLATION FACILE



MICRO VENTILAÇÃO
MICRO VENTILATION
MICRO VENTILACIÓN
MICRO VENTILATION



DOBRADIÇA SUPERIOR
UPPER HINGE
DOBLADIACIÓN SUPERIOR
CHARNIÈRE SUPERIEURE



OSCILOBATENTE OCULTO

CONCEALED TILT AND TURN
 OSCIOBATIENTE OCULTO
 CACHÉ OSCILLO-BATTANT



NORMA - STANDARD
 NORMA - NORME
 EN 13126

5103	OSCILO OCULTO 5103
5103 C/C	OSCILO OCULTO 5103 C/ CHAVE
9595	OSCILO OCULTO 9595
9595 C/C	OSCILO OCULTO 9595 C/ CHAVE
9595 S/P	OSCILO OCULTO 9595 S/ PEGA
KIT 9215 DTA	KIT DOB OSCILO OCULTA TAM 1 DTA 470/700
KIT 9215 ESQ	KIT DOB OSCILO OCULTA TAM 1 ESQ 470/700
KIT 9216 DTA	KIT DOB OSCILO OCULTA TAM 2 DTA 600/1500
KIT 9216 ESQ	KIT DOB OSCILO OCULTA TAM 2 ESQ 600/1500

5104 AM	OSCILO OCULTO 5104 AM
5104 AM C/C	OSCILO OCULTO 5104 AM C/ CHAVE
9596 AM	OSCILO OCULTO 9596 AM
9596 AM C/C	OSCILO OCULTO 9596 AM C/ CHAVE
9596 AM S/P	OSCILO OCULTO 9596 AM S/ PEGA
9597 AL C/C	OSCILO OCULTO 9597 AB. LÓGICA C/ CHAVE
K.V	KIT VERTICAL OCULTO
C.A	COMPASSO ADICIONAL (+1000)

2ª FOLHA



KIT 9218 DTA	KIT DOB 2A FOLHA / BATENTE OCULTA DTA	10 cj
KIT 9218 ESQ	KIT DOB 2A FOLHA / BATENTE OCULTA ESQ	10 cj
9203	FECHOS ALUMÍNIO	24 cj
9204	FECHOS ZAMAK	12 cj
9212	BIDIRECCIONAL	24 un.
9213	BIDIRECCIONAL - AM/AL	24 un.

NORMA - STANDARD
NORMA - NORME
EN 13126

5160
5160 C/C
5165
9999
MR100LA



AFINAÇÃO ARO FIXO
 FIXED ARM SETTING
 AFINACIÓN ARO FIJO
 REGLAGE DE BRAS FIXE



5160
 PUXADORES · HANDLES
 MANILLAS · BÉQUILLES

Opcional · Optional
 Option · Optionen

5165
 PUXADORES · HANDLES
 MANILLAS · BÉQUILLES

Opcional · Optional
 Option · Optionen

5160 C/C
 PUXADORES · HANDLES
 MANILLAS · BÉQUILLES

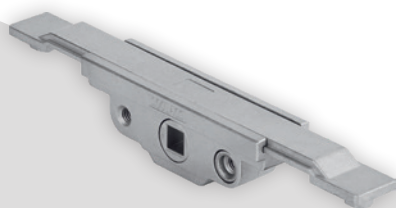

MR100LA

OSCIOBATENTE | a=A-227,5
 b=B-201,5

OPÇÕES · OPTIONS
OPCIONES · OPTIONS

- KIT VERTICAL
- KIT HORIZONTAL
- COMPASSO ADICIONAL
- OB 09701/ 09707 P. FECHO COM AF
- OB 1013 SUPLEMENTO P. FECHO
- MICRO
- COMPASSO MINI 34/45
- COMPASSO 38/55
- COMPASSO 55/90
- COMPASSO 90/120

NORMA - STANDARD
NORMA - NORME

EN 13126

OSCILOBATENTE OCULTO

CONCEALED TILT AND TURN
OSCILOBATIENTE OCULTO
CACHÉ OSCILLO-BATTANT



5165
PUXADORES · HANDLES
MANILLAS · BÉQUILLES



Opcional · Optional
Option · Optionen
5160
PUXADORES · HANDLES
MANILLAS · BÉQUILLES



Opcional · Optional
Option · Optionen
5160 C/C
PUXADORES · HANDLES
MANILLAS · BÉQUILLES

NORMA - STANDARD
NORMA - NORME
EN 13126

5103	OSCILO OCULTO 5103
5103 C/C	OSCILO OCULTO 5103 C/ CHAVE
5160	OSCILO OCULTO 5160
5160 C/C	OSCILO OCULTO 5160 C/ CHAVE
5165	OSCILO OCULTO 5165
MR100LA	CASSETTE UNIDIR. MR100LA.19MM BLQ90°

KIT 9215 DTA	KIT DOB OSCILO OCULTA TAM 1 DTA 470/700
KIT 9215 ESQ	KIT DOB OSCILO OCULTA TAM 1 ESQ 470/700
KIT 9216 DTA	KIT DOB OSCILO OCULTA TAM 2 DTA 600/1500
KIT 9216 ESQ	KIT DOB OSCILO OCULTA TAM 2 ESQ 600/1500
K.V	KIT VERTICAL OCULTO
C.A	COMPASSO ADICIONAL (+1000)



ASSA ABLOY





QUAD

5110



5110 C/C
5120 1P C/C



kit patilhas
esquerda 5110

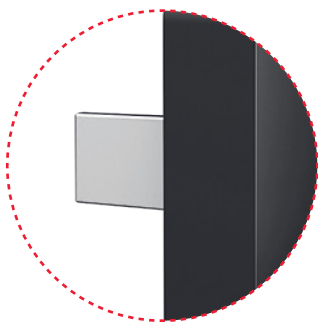

5120 1P

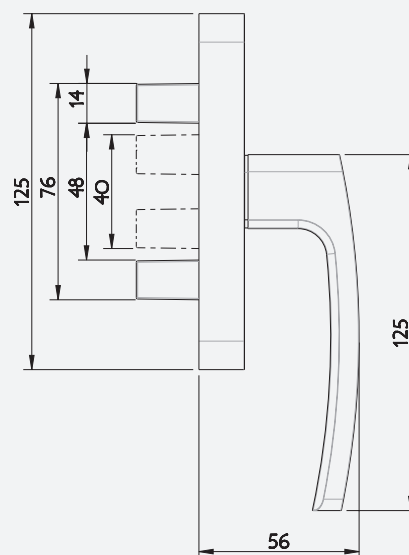
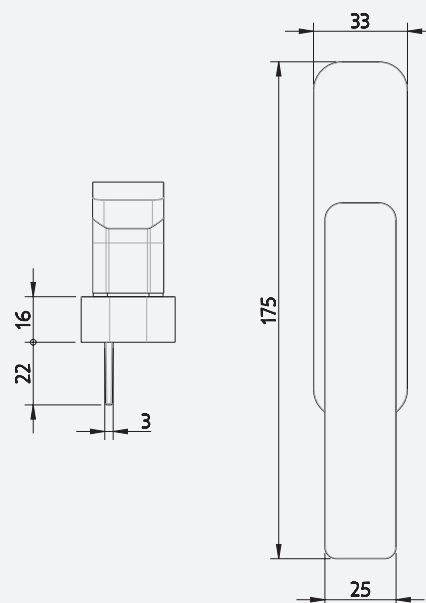

EMBALAGEM - PACKAGING
EMPAQUETADO - EMBALLAGE

12 unidades por caixa
12 pieces per box
12 unidades por caja
12 pieces par boîte

MATERIAIS - MATERIALS
MATERIALES - MATERIAUX

Alumínio - Zamak - Inox
Aluminium - Zamak - Stainless steel
Aluminio - Zamak - Acero inox
Aluminium - Zamak - Inox

FIXAÇÃO - FIXING
FIJACIÓN - FIXATION

Parafusos incluídos
Screws included
Tornillos incluidos
Vis inclus

ACABAMENTO - FINISHING
ACABADOS - FINITION

Lacado
Powder painting
Lacado
Laqué

NORMA - STANDARD
NORMA - NORME

EN 1670
EN 13126

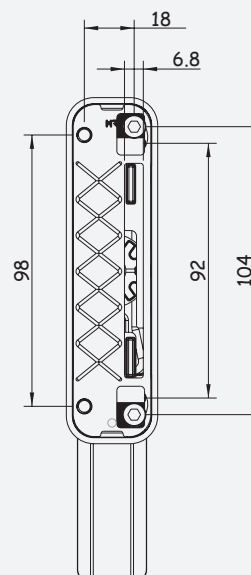

5260

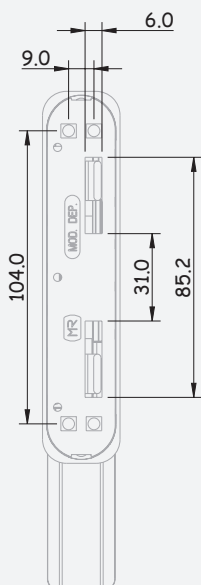
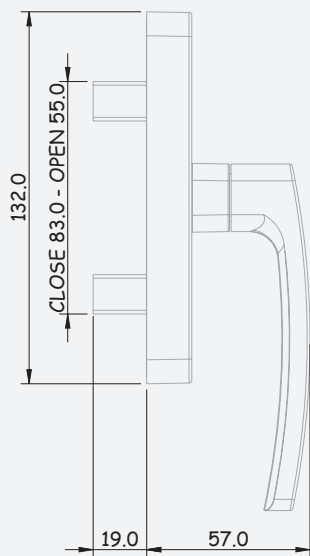
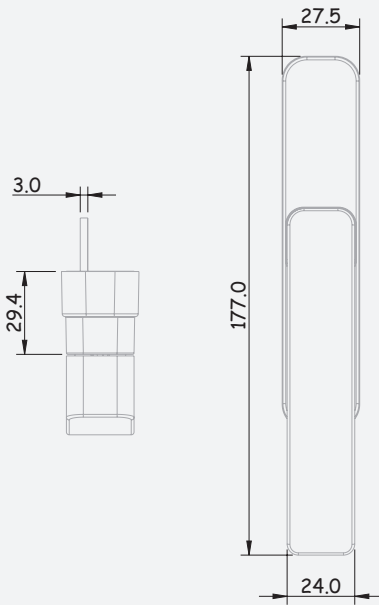

5260 C/C

EMBALAGEM - PACKAGING
EMPAQUETADO - EMBALLAGE

12 unidades por caixa
12 pieces per box
12 unidades por caja
12 pieces par boîte

ACABAMENTO - FINISHING
ACABADOS - FINITION

Lacado
Powder painting
Lacado
Laqué

MATERIAIS - MATERIALS
MATERIALES - MATERIAUX

Alumínio - Zamak - Inox
Aluminium - Zamak - Stainless steel
Aluminio - Zamak - Acero inox
Aluminium - Zamak - Inox

NORMA - STANDARD
NORMA - NORME

EN 1670
EN 13126

FIXAÇÃO - FIXING
FIJACIÓN - FIXATION

Parafusos incluídos
Screws included
Tornillos incluidos
Vis inclus

5115

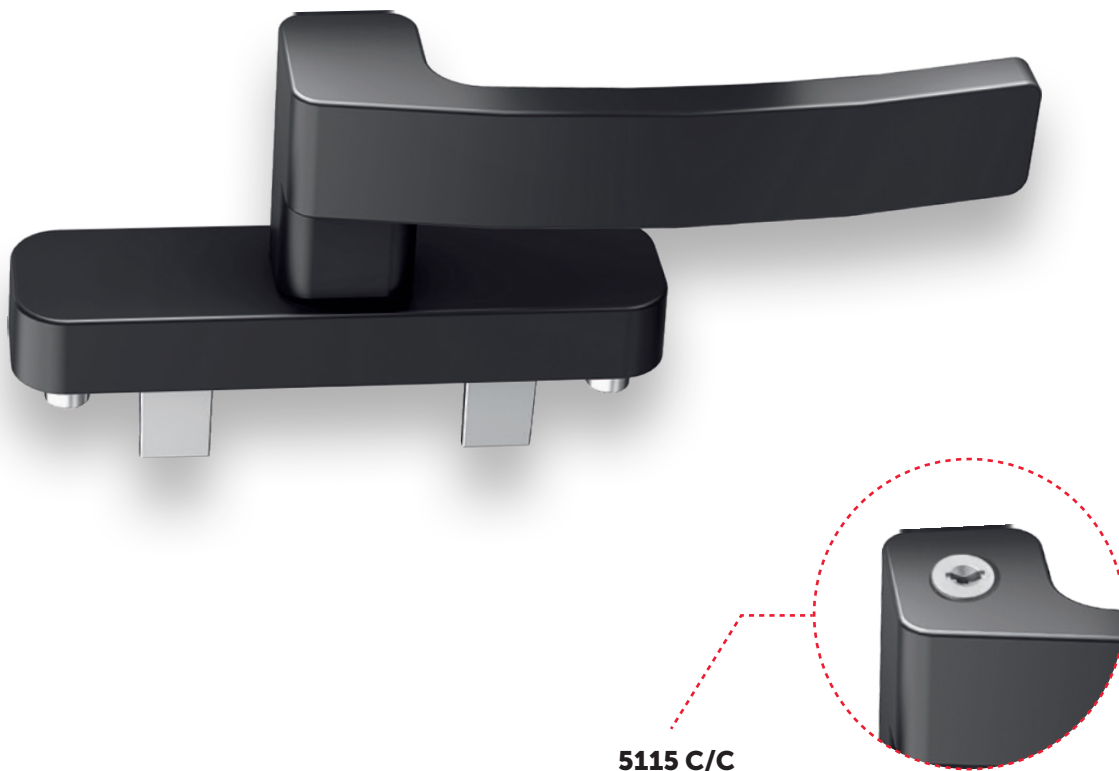

**EMBALAGEM - PACKAGING
EMPAQUETADO - EMBALLAGE**

12 unidades por caixa

12 pieces per box
12 unidades por caja
12 pieces par boîte

**MATERIAIS - MATERIALS
MATERIALES - MATERIAUX**

Alumínio - Zamak - Inox

Aluminium - Zamak - Stainless steel
Aluminio - Zamak - Acero inox
Aluminium - Zamak - Inox

**FIXAÇÃO - FIXING
FIJACIÓN - FIXATION**

Parafusos incluídos

Screws included
Tornillos incluidos
Vis inclus

**ACABAMENTO - FINISHING
ACABADOS - FINITION**

Lacado

Powder painting
Lacado
Laqué

**NORMA - STANDARD
NORMA - NORME**

EN 1670
EN 13126

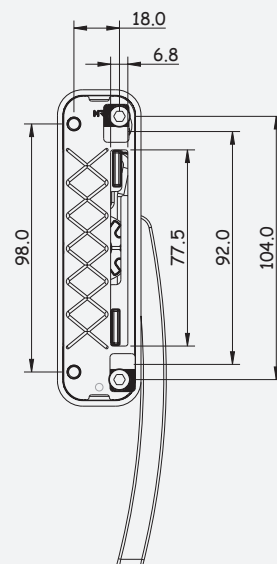
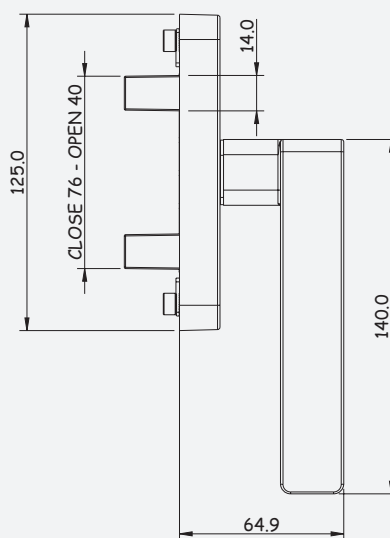
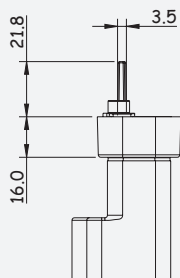
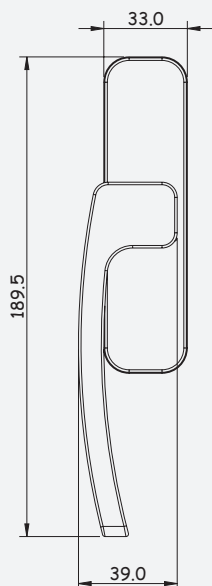

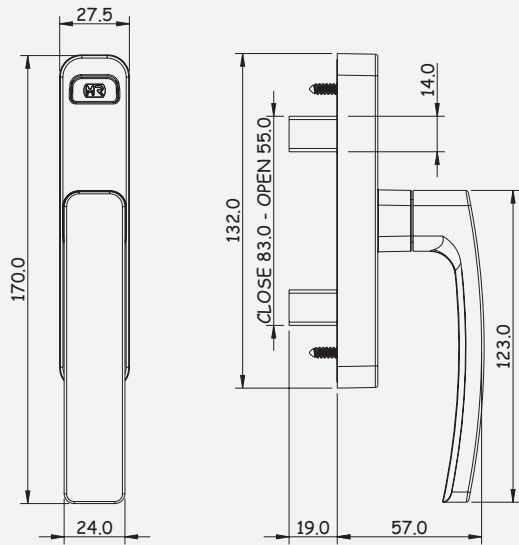

5200

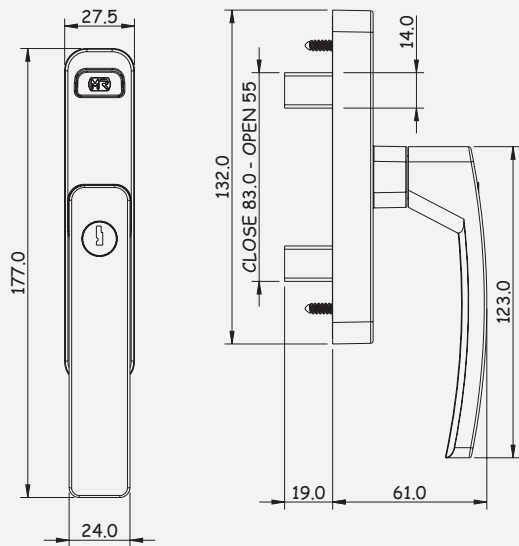

5200 C/C

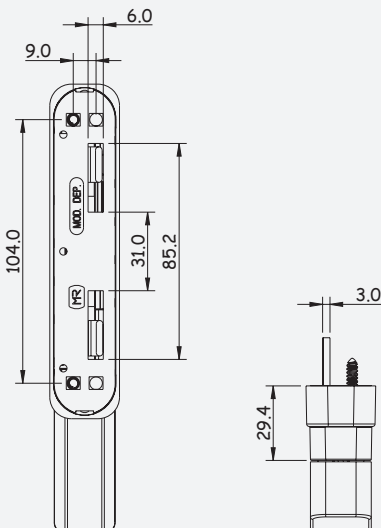

5200



5200 C/C

**EMBALAGEM - PACKAGING
EMPAQUETADO - EMBALLAGE**

12 unidades por caixa
12 pieces per box
12 unidades por caja
12 pieces par boîte

**MATERIAIS - MATERIALS
MATERIALES - MATERIAUX**

Alumínio - Zamak - Inox
Aluminium - Zamak - Stainless steel
Aluminio - Zamak - Acero inox
Aluminium - Zamak - Inox

**FIXAÇÃO - FIXING
FIJACIÓN - FIXATION**

Parafusos incluídos
Screws included
Tornillos incluidos
Vis inclus

**ACABAMENTO - FINISHING
ACABADOS - FINITION**

Lacado
Powder painting
Lacado
Laqué

**NORMA - STANDARD
NORMA - NORME**

EN 1670
EN 13126

5215
5216



5215 C/C
5216 C/C
5220 C/C



5220

EMBALAGEM - PACKAGING
EMPAQUETADO - EMBALLAGE

12 unidades por caixa
12 pieces per box
12 unidades por caja
12 pieces par boîte

MATERIAIS - MATERIALS
MATERIALES - MATERIAUX

Alumínio - Zamak - Inox
Aluminium - Zamak - Stainless steel
Aluminio - Zamak - Acero inox
Aluminium - Zamak - Inox

FIXAÇÃO - FIXING
FIJACIÓN - FIXATION

Parafusos incluídos
Screws included
Tornillos incluidos
Vis inclus

ACABAMENTO - FINISHING
ACABADOS - FINITION

Lacado
Powder painting
Lacado
Laqué

NORMA - STANDARD
NORMA - NORME

EN 1670
EN 13126

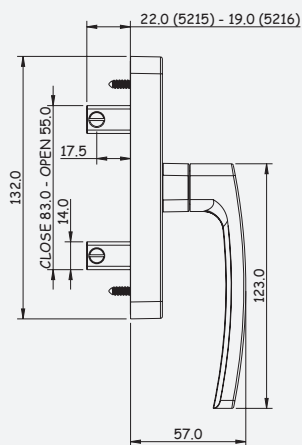
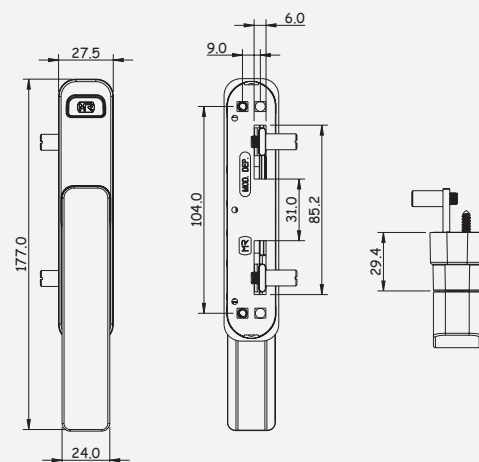

5215 / 5216

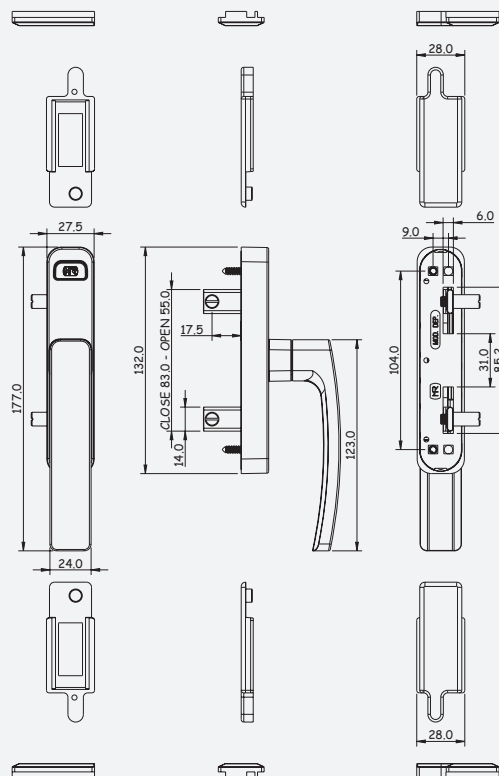

5220

5230



**Ponto fecho CE
MR2008**

**EMBALAGEM - PACKAGING
EMPAQUETADO - EMBALLAGE**

12 unidades por caixa
12 pieces per box
12 unidades por caja
12 pieces par boîte

**MATERIAIS - MATERIALS
MATERIALES - MATERIAUX**

Alumínio - Zamak - Inox
Aluminium - Zamak - Stainless steel
Aluminio - Zamak - Acero inox
Aluminium - Zamak - Inox

**FIXAÇÃO - FIXING
FIJACIÓN - FIXATION**

Parafusos incluídos
Screws included
Tornillos incluidos
Vis inclus

**ACABAMENTO - FINISHING
ACABADOS - FINITION**

Lacado
Powder painting
Lacado
Laqué

**NORMA - STANDARD
NORMA - NORME**

EN 1670
EN 13126

**OBSERVAÇÕES - COMMENTS
OBSERVACIONES - OBSERVATIONS**

**Ponto fecho CE
MR2008**
50 unidades por caixa
50 pieces per box
50 unidades por caja
50 pieces par boîte

CREMONE ABERTURA EXTERIOR · CREMONE OUTWARDS OPENING · CREMONA APERTURA EXTERIOR · CREMONE OUVERTURE EXTERIEUR

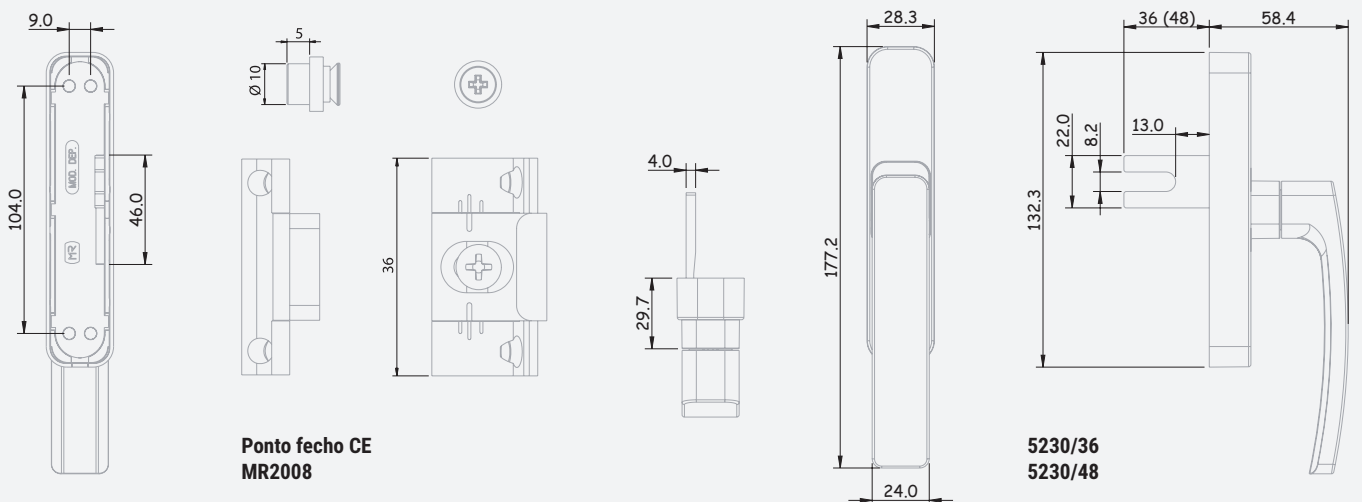

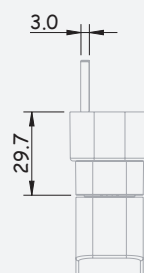
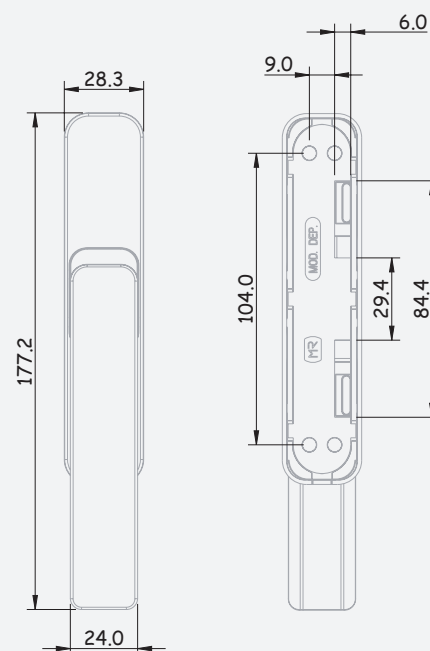

5231

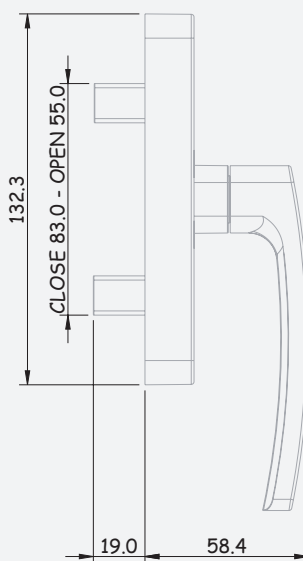

**EMBALAGEM - PACKAGING
EMPAQUETADO - EMBALLAGE**

12 unidades por caixa
12 pieces per box
12 unidades por caja
12 pieces par boîte

**MATERIAIS - MATERIALS
MATERIALES - MATERIAUX**

Alumínio - Zamak - Inox
Aluminium - Zamak - Stainless steel
Aluminio - Zamak - Acero inox
Aluminium - Zamak - Inox

**FIXAÇÃO - FIXING
FIJACIÓN - FIXATION**

Parafusos incluídos
Screws included
Tornillos incluidos
Vis inclus

**ACABAMENTO - FINISHING
ACABADOS - FINITION**

Lacado
Powder painting
Lacado
Laqué

**NORMA - STANDARD
NORMA - NORME**

EN 1670
EN 13126

**OBSERVAÇÕES - COMMENTS
OBSERVACIONES - OBSERVATIONS**

5232
pat. transmissão grande = 22mm

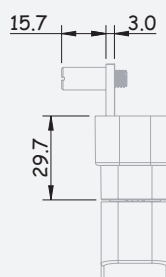

5232

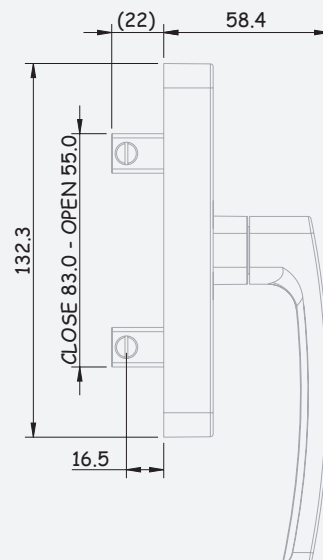



5250



**5251
5252**

**EMBALAGEM - PACKAGING
EMPAQUETADO - EMBALLAGE**

12 unidades por caixa
12 pieces per box
12 unidades por caja
12 pieces par boîte

**MATERIAIS - MATERIALS
MATERIALES - MATERIAUX**

Alumínio - Zamak - Inox
Aluminium - Zamak - Stainless steel
Aluminio - Zamak - Acero inox
Aluminium - Zamak - Inox

**FIXAÇÃO - FIXING
FIJACIÓN - FIXATION**

Parafusos incluídos
Screws included
Tornillos incluidos
Vis inclus

**ACABAMENTO - FINISHING
ACABADOS - FINITION**

Lacado
Powder painting
Lacado
Laqué

**NORMA - STANDARD
NORMA - NORME**

EN 1670
EN 13126

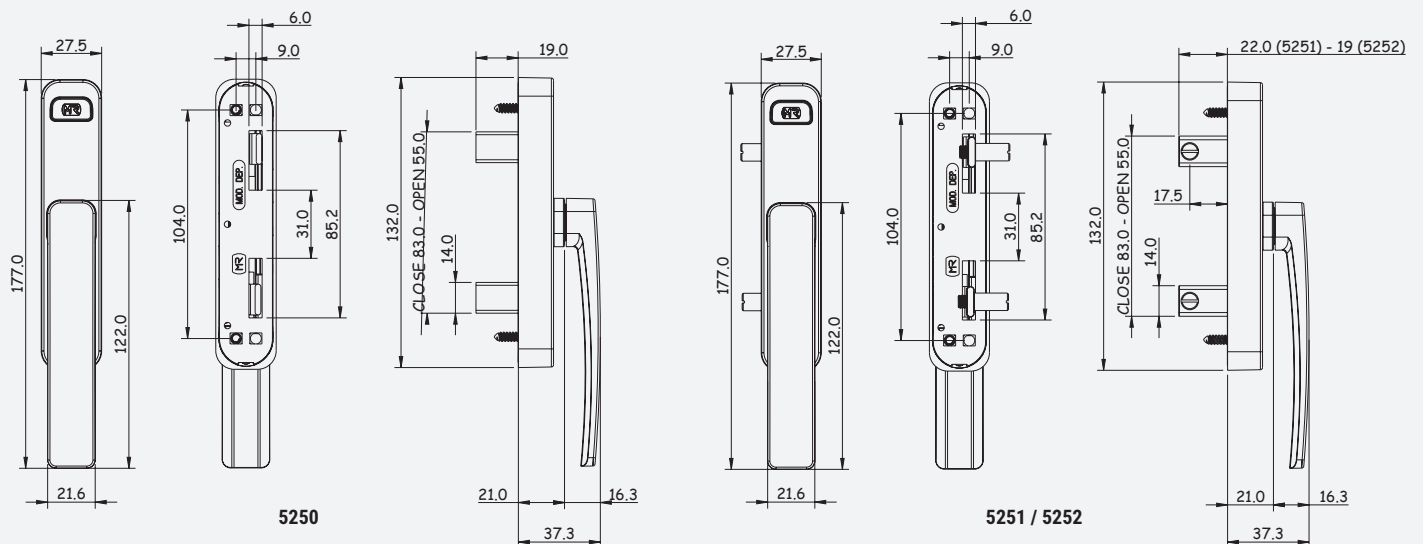

5135



EMBALAGEM - PACKAGING
EMPAQUETADO - EMBALLAGE

12 pares por caixa
12 pairs per box
12 pares por caja
12 paires par boîte

MATERIAIS - MATERIALS
MATERIALES - MATERIAUX

Alumínio - Zamak - Inox
Aluminium - Zamak - Stainless steel
Aluminio - Zamak - Acero inox
Aluminium - Zamak - Inox

FIXAÇÃO - FIXING
FIJACIÓN - FIXATION

Parafusos incluídos
Screws included
Tornillos incluidos
Vis inclus

ACABAMENTO - FINISHING
ACABADOS - FINITION

Lacado
Powder painting
Lacado
Laqué

NORMA - STANDARD
NORMA - NORME

EN 1670
EN 1906

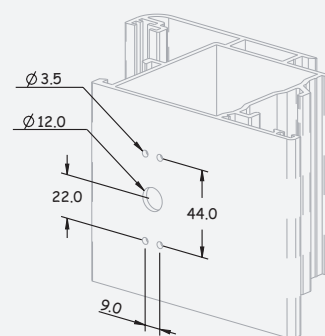
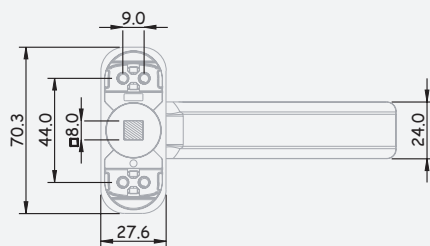
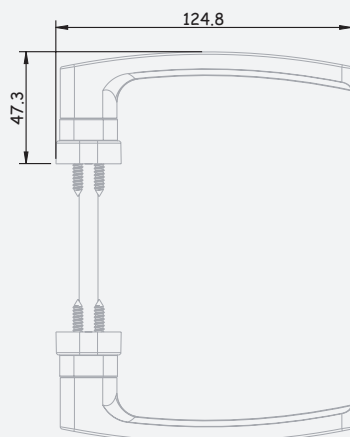

5140



5000

EMBALAGEM - PACKAGING
EMPAQUETADO - EMBALLAGE

12 pares por caixa
12 pairs per box
12 pares por caja
12 paires par boîte

MATERIAIS - MATERIALS
MATERIALES - MATERIAUX

Alumínio - Zamak - Inox
Aluminium - Zamak - Stainless steel
Aluminio - Zamak - Acero inox
Aluminium - Zamak - Inox

FIXAÇÃO - FIXING
FIJACIÓN - FIXATION

Parafusos incluídos
Screws included
Tornillos incluidos
Vis inclus

ACABAMENTO - FINISHING
ACABADOS - FINITION

Lacado
Powder painting
Lacado
Laqué

NORMA - STANDARD
NORMA - NORME

EN 1670
EN 1906

OBSERVAÇÕES - COMENTS
OBSERVACIONES - OBSERVATIONS

5000
100 unidades por caixa
100 pieces per box
100 unidades por caja
100 pieces par boîte

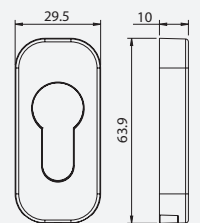
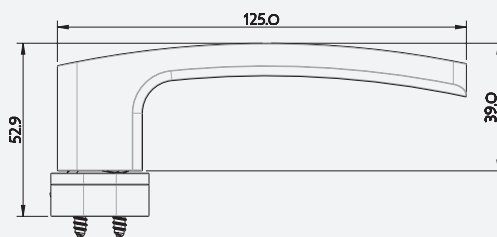
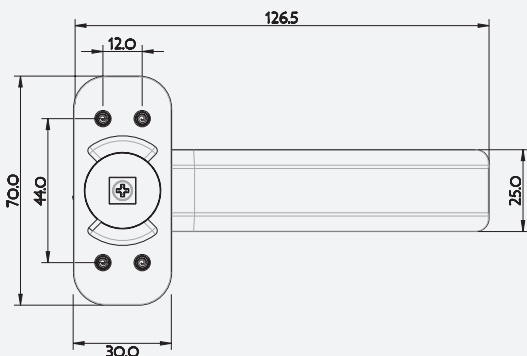

5000

5150



5151

EMBALAGEM - PACKAGING
EMPAQUETADO - EMBALLAGE

6 pares por caixa
6 pairs per box
6 pares por caja
6 paires par boîte

MATERIAIS - MATERIALS
MATERIALES - MATERIAUX

Alumínio - Zamak - Inox
Aluminium - Zamak - Stainless steel
Aluminio - Zamak - Acero inox
Aluminium - Zamak - Inox

FIXAÇÃO - FIXING
FIJACIÓN - FIXATION

Parafusos incluídos
Screws included
Tornillos incluidos
Vis inclus

ACABAMENTO - FINISHING
ACABADOS - FINITION

Lacado
Powder painting
Lacado
Laqué

NORMA - STANDARD
NORMA - NORME

EN 1670
EN 1906

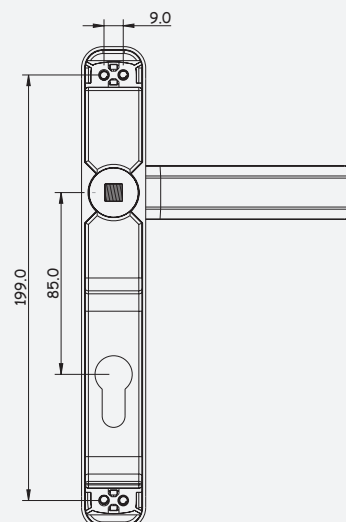
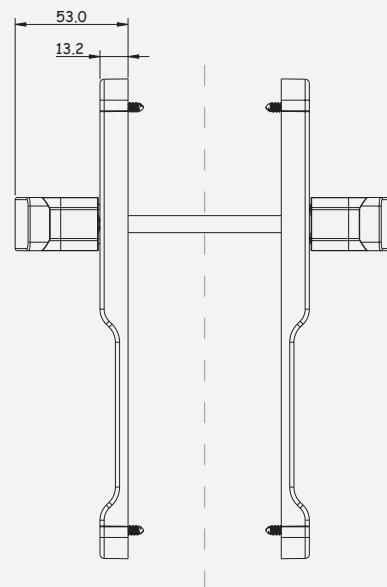
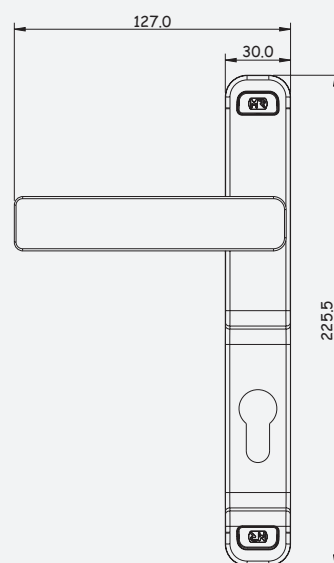

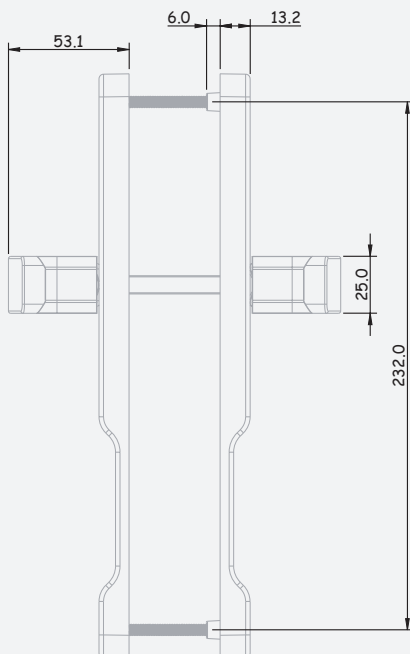
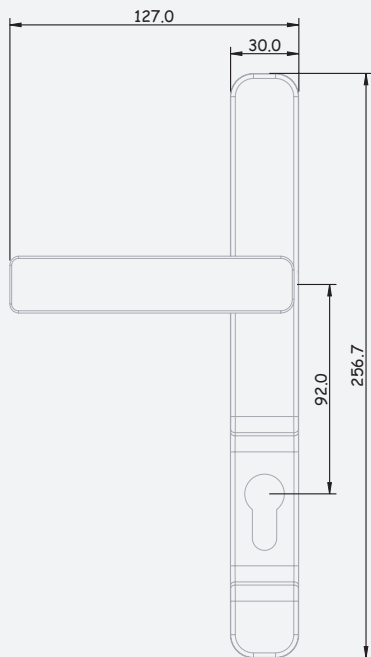

5152/92 (ESQ.)
5152/92 (DIR.)



EMBALAGEM - PACKAGING
EMPAQUETADO - EMBALLAGE

6 pares por caixa
6 pairs per box
6 pares por caja
6 paires par boîte

MATERIAIS - MATERIALS
MATERIALES - MATERIAUX

Alumínio - Zamak - Inox
Aluminium - Zamak - Stainless steel
Aluminio - Zamak - Acero inox
Aluminium - Zamak - Inox

FIXAÇÃO - FIXING
FIJACIÓN - FIXATION

Parafusos incluídos
Screws included
Tornillos incluidos
Vis inclus

ACABAMENTO - FINISHING
ACABADOS - FINITION

Lacado
Powder painting
Lacado
Laqué

NORMA - STANDARD
NORMA - NORME

EN 1670
EN 1906

5180 (ESQ.)



5180 C/C
5185 C/C

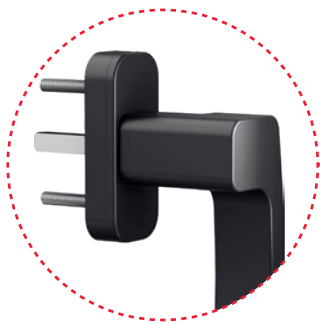

5185 (DIR.)

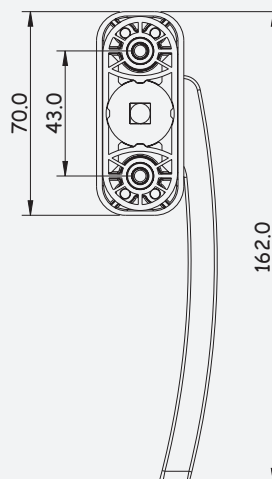
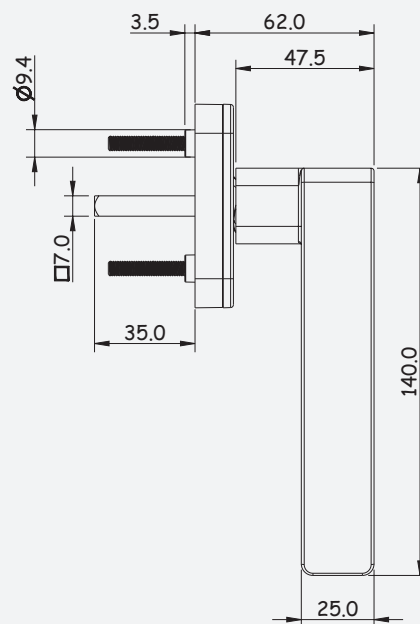
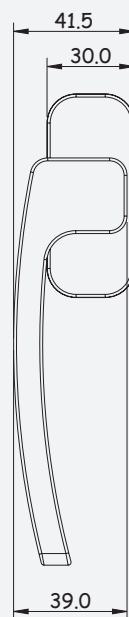

EMBALAGEM - PACKAGING
EMPAQUETADO - EMBALLAGE

12 unidades por caixa
12 pieces per box
12 unidades por caja
12 pieces par boîte

MATERIAIS - MATERIALS
MATERIALES - MATERIAUX

Alumínio - Zamak - Inox
Aluminium - Zamak - Stainless steel
Aluminio - Zamak - Acero inox
Aluminium - Zamak - Inox

FIXAÇÃO - FIXING
FIJACIÓN - FIXATION

Parafusos incluídos
Screws included
Tornillos incluidos
Vis inclus

ACABAMENTO - FINISHING
ACABADOS - FINITION

Lacado
Powder painting
Lacado
Laqué

NORMA - STANDARD
NORMA - NORME

EN 1670
EN 13126

5160

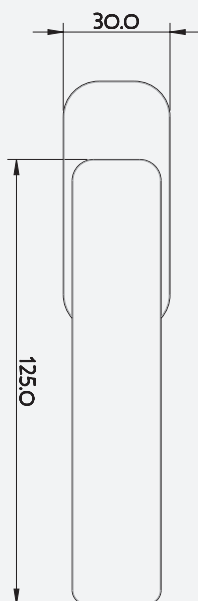
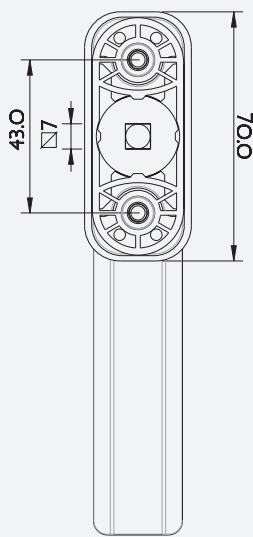

5160 C/C

EMBALAGEM - PACKAGING
EMPAQUETADO - EMBALLAGE

24 unidades por caixa
24 pieces per box
24 unidades por caja
24 pieces par boîte

ACABAMENTO - FINISHING
ACABADOS - FINITION

Lacado
Powder painting
Lacado
Laqué

MATERIAIS - MATERIALS
MATERIALES - MATERIAUX

Alumínio - Zamak - Inox
Aluminium - Zamak - Stainless steel
Aluminio - Zamak - Acero inox
Aluminium - Zamak - Inox

NORMA - STANDARD
NORMA - NORME

EN 1670
EN 13126

FIXAÇÃO - FIXING
FIJACIÓN - FIXATION

Parafusos incluídos
Screws included
Tornillos incluidos
Vis inclus

5165



**Reforço de
Fixação**

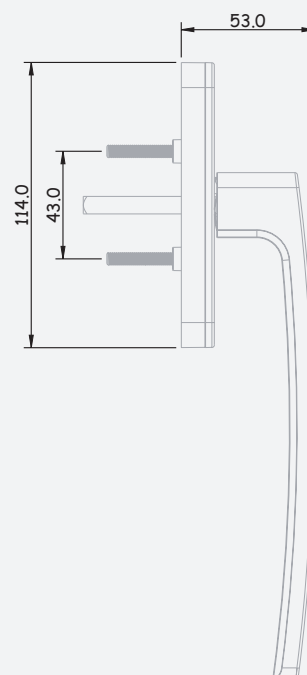
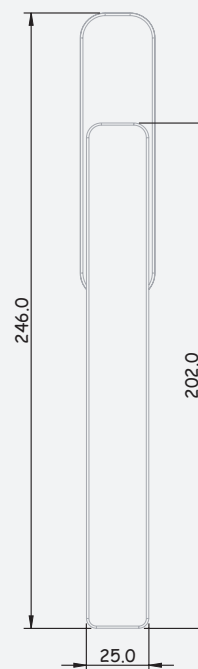

**EMBALAGEM - PACKAGING
EMPAQUETADO - EMBALLAGE**

6 unidades por caixa
6 pieces per box
6 unidades por caja
6 pieces par boîte

**MATERIAIS - MATERIALS
MATERIALES - MATERIAUX**

Alumínio - Zamak - Inox
Aluminium - Zamak - Stainless steel
Aluminio - Zamak - Acero inox
Aluminium - Zamak - Inox

**FIXAÇÃO - FIXING
FIJACIÓN - FIXATION**

Parafusos incluídos
Screws included
Tornillos incluidos
Vis inclus

**ACABAMENTO - FINISHING
ACABADOS - FINITION**

Lacado
Powder painting
Lacado
Laqué

**NORMA - STANDARD
NORMA - NORME**

EN 1670
EN 13126

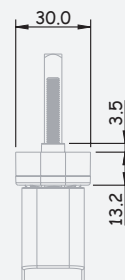

5280

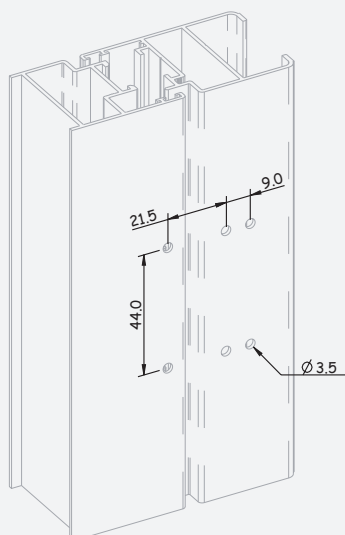
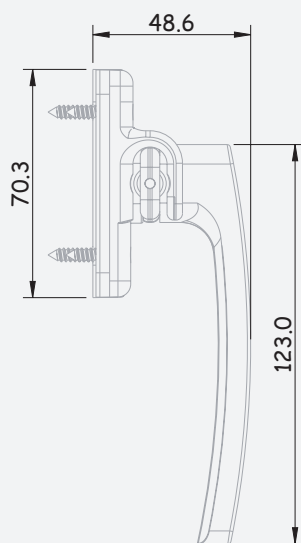
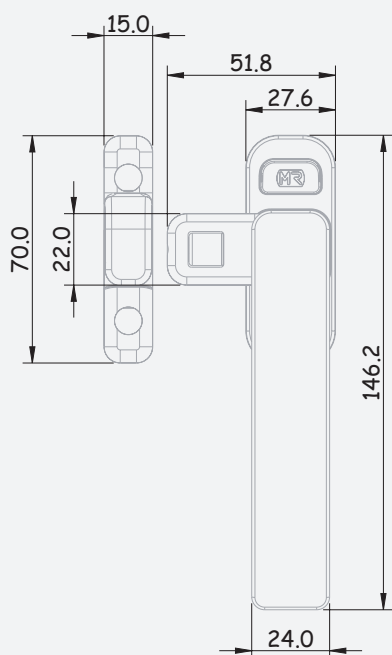

EMBALAGEM - PACKAGING
EMPAQUETADO - EMBALLAGE

24 unidades por caixa
 24 pieces per box
 24 unidades por caja
 24 pieces par boîte

MATERIAIS - MATERIALS
MATERIALES - MATERIAUX

Alumínio - Zamak - Inox
 Aluminium - Zamak - Stainless steel
 Aluminio - Zamak - Acero inox
 Aluminium - Zamak - Inox

FIXAÇÃO - FIXING
FIJACIÓN - FIXATION

Parafusos incluídos
 Screws included
 Tornillos incluídos
 Vis inclus

ACABAMENTO - FINISHING
ACABADOS - FINITION

Lacado
 Powder painting
 Lacado
 Laqué

NORMA - STANDARD
NORMA - NORME

EN 1670
 EN 13126

OBSERVAÇÕES - COMMENTS
OBSERVACIONES - OBSERVATIONS

Inclui Ressonância Batente
 1,2mm e 3mm, não inclui
 calço de 3 e 5 mm

MR100LA

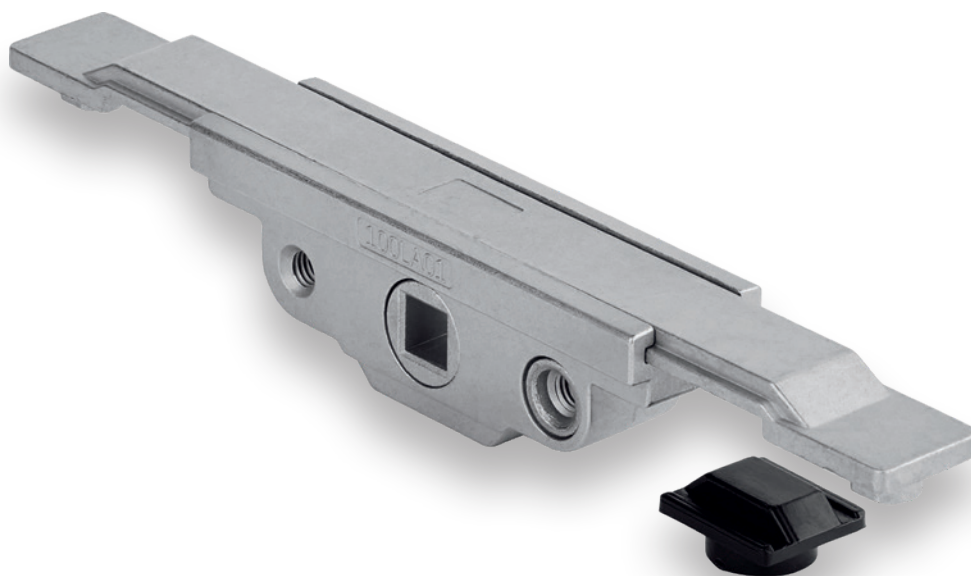

**EMBALAGEM - PACKAGING
 EMPAQUETADO - EMBALLAGE**

24 unidades por caixa
 24 pieces per box
 24 unidades por caja
 24 pieces par boîte

**MATERIAIS - MATERIALS
 MATERIALES - MATERIAUX**

Zamak
 Zamak
 Zamak
 Zamak

**FIXAÇÃO - FIXING
 FIJACIÓN - FIXATION**

Parafusos incluídos
 Screws included
 Tornillos incluidos
 Vis inclus

**NORMA - STANDARD
 NORMA - NORME**

EN 1670
 EN 13126

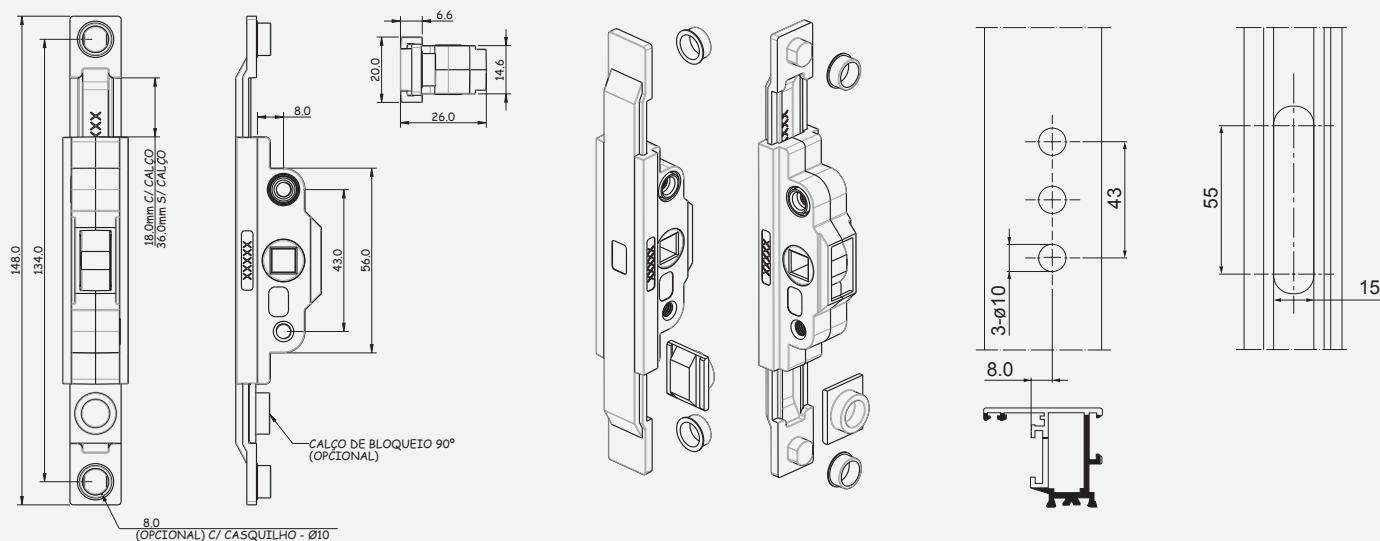

5110

CREMONES · CREMONES
CREMONAS · CREMONES

UMA LINHA INTEMPORAL

LINE TIMELESS · UNA LÍNEA ETERNO · UNE LIGNE INTEMPOREL

QUAD



ASSA ABLOY





MONDIAL



www.mr.pt

MONDIAL



**M41 U C/C/31
(JALOUSIE)***



M46 1P12 C/C

**EMBALAGEM - PACKAGING
EMPAQUETADO - EMBALLAGE**

12 unidades por caixa
12 pieces per box
12 unidades por caja
12 pieces par boîte

**MATERIAIS - MATERIALS
MATERIALES - MATERIAUX**

Alumínio - Zamak - Inox
Aluminium - Zamak - Stainless steel
Aluminio - Zamak - Acero inox
Aluminium - Zamak - Inox

**FIXAÇÃO - FIXING
FIJACIÓN - FIXATION**

Parafusos incluídos
Screws included
Tornillos incluidos
Vis inclus

**ACABAMENTO - FINISHING
ACABADOS - FINITION**

Lacado
Powder painting
Lacado
Laqué

**NORMA - STANDARD
NORMA - NORME**

EN 1670
EN 13126

* Jalousie corpo aberto, fixação frontal U=8

CREMONE 1 PALA · CREMONE 1 PALA · CREMONA 1 PALA · CREMONE 1 PALA

M40 / M41

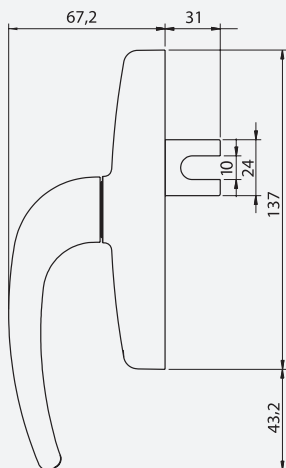
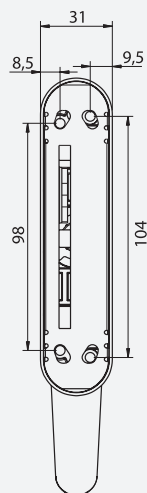

M45 / M46 / M50 / M51

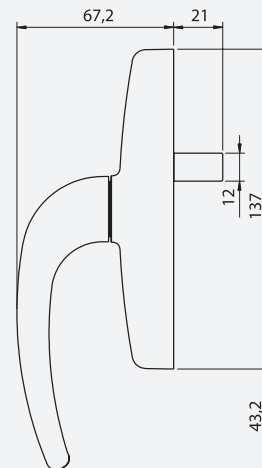

CREMONE PARA C. EUROPEIA · CREMONE FOR E.G. SERIES
CREMONA PARA C. EUROPEO · CREMONE POUR C. EUROPÉENNE

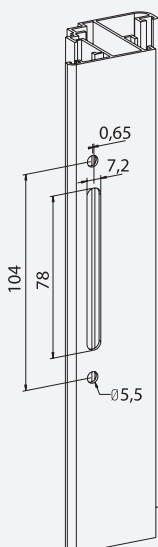
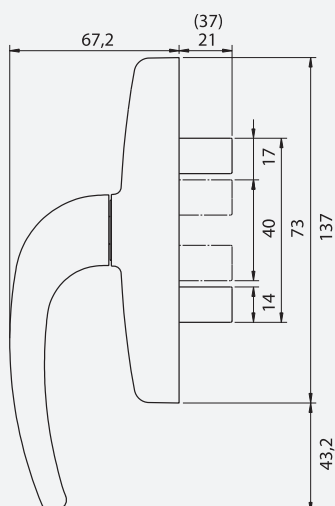
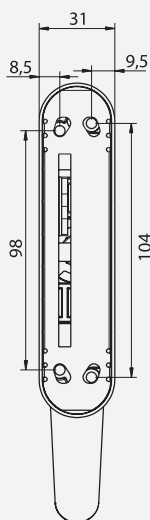

MONDIAL

M20 P21.14
M30 P37.14



M21 P21.14 C/C
M31 P37.14 C/C

EMBALAGEM - PACKAGING
EMPAQUETADO - EMBALLAGE

12 unidades por caixa
12 pieces per box
12 unidades por caja
12 pieces par boîte

MATERIAIS - MATERIALS
MATERIALES - MATERIAUX

Alumínio - Zamak - Inox
Aluminium - Zamak - Stainless steel
Aluminio - Zamak - Acero inox
Aluminium - Zamak - Inox

FIXAÇÃO - FIXING
FIJACIÓN - FIXATION

Parafusos incluídos
Screws included
Tornillos incluidos
Vis inclus

ACABAMENTO - FINISHING
ACABADOS - FINITION

Lacado
Powder painting
Lacado
Laqué

NORMA - STANDARD
NORMA - NORME

EN 1670
EN 13126

MONDIAL

M23 F P21.14
M33 F P37.14



CREMONE PARA FACHADAS
CREMONE FOR CURTAIN WALL
CREMONA PARA MURO DE CORTINA
CREMONE FOUR FAÇADE

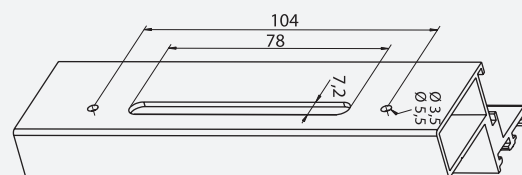
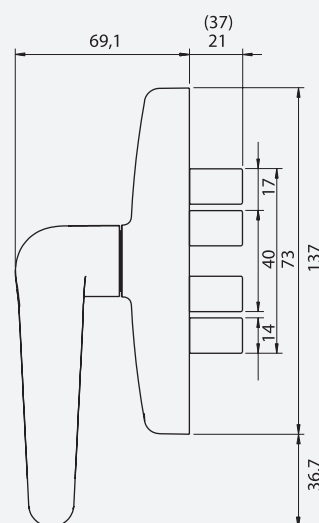
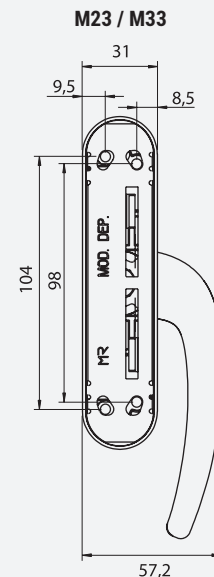

EMBALAGEM - PACKAGING
EMPAQUETADO - EMBALLAGE

12 unidades por caixa
12 pieces per box
12 unidades por caja
12 pieces par boîte

MATERIAIS - MATERIALS
MATERIALES - MATERIAUX

Alumínio - Zamak - Inox
Aluminium - Zamak - Stainless steel
Aluminio - Zamak - Acero inox
Aluminium - Zamak - Inox

FIXAÇÃO - FIXING
FIJACIÓN - FIXATION

Parafusos incluídos
Screws included
Tornillos incluidos
Vis inclus

ACABAMENTO - FINISHING
ACABADOS - FINITION

Lacado
Powder painting
Lacado
Laqué

NORMA - STANDARD
NORMA - NORME

EN 1670
EN 13126

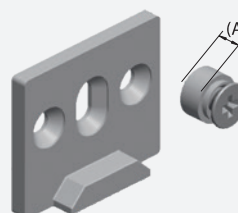

PONTO DE FECHO - CLOSED POINT
PUNTO DE CIELO - POINT FERMÉ

REF. ^a	Tam. (A)
33532	8,5 mm
33533	6,5 mm
	10,5 mm

MONDIAL

MULETA C/ MOLA RECUPERAÇÃO
SPRING-LOADED HANDLE FOR DOORS
MANILLA C/ MUELLE DE RECUPERACIÓN · BEQUILLE AVEC
RESORT DE RAPPEL POUR PORTES

M60 $\varnothing 8$

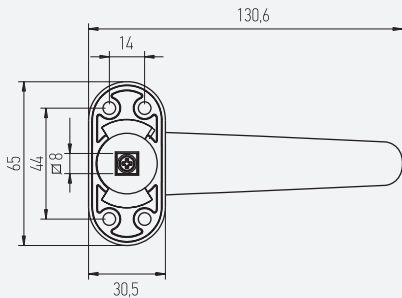

M60 FR $\varnothing 8$

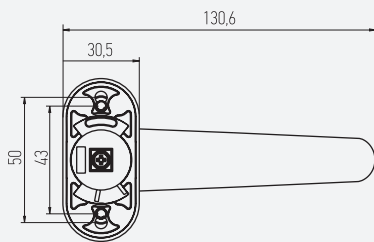

Altura - 62,1 mm

M69

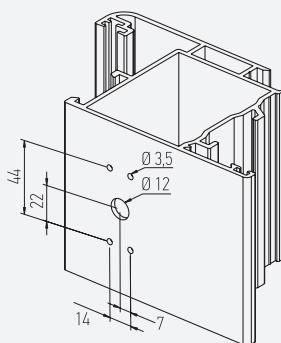
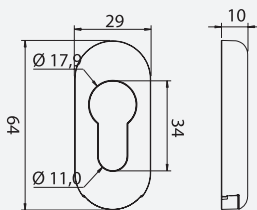

M60 $\varnothing 8$
M60 FR $\varnothing 8$



M69

EMBALAGEM - PACKAGING
EMPAQUETADO - EMBALLAGE

M60 $\varnothing 8$
12 pares por caixa
12 pairs per box
12 pares por caja
12 paires par boîte

ACABAMENTO - FINISHING
ACABADOS - FINITION

Lacado
Powder painting
Lacado
Laqué

MATERIAIS - MATERIALS
MATERIALES - MATERIAUX

Alumínio - Zamak - Inox
Aluminium - Zamak - Stainless steel
Aluminio - Zamak - Acero inox
Aluminium - Zamak - Inox

NORMA - STANDARD
NORMA - NORME

EN 1670
EN 1906

OBSERVAÇÕES - COMMENTS
OBSERVACIONES - OBSERVATIONS

M69
100 unidades por caixa
100 pieces per box
100 unidades por caja
100 pieces par boîte

FIXAÇÃO - FIXING
FIJACIÓN - FIXATION

Parafusos incluídos
Screws included
Tornillos incluidos
Vis inclus

MONDIAL

M63 \square 8



MULETA C/ MOLA RECUPERAÇÃO
SPRING-LOADED HANDLE FOR DOORS
MANILLA C/ MUELLE DE RECUPERACIÓN · BEQUILLE AVEC
RESORT DE RAPPEL POUR PORTES

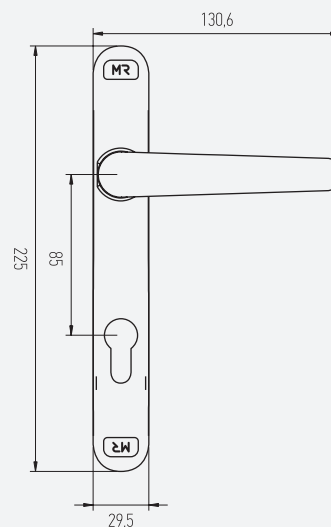
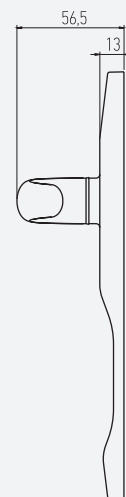

EMBALAGEM - PACKAGING
EMPAQUETADO - EMBALLAGE

M63 \square 8
6 pares por caixa
6 pairs per box
6 pares por caixa
6 paires par boîte

ACABAMENTO - FINISHING
ACABADOS - FINITION

Lacado
Powder painting
Lacado
Laqué

MATERIAIS - MATERIALS
MATERIALES - MATERIAUX

Alumínio - Zamak - Inox
Aluminium - Zamak - Stainless steel
Aluminio - Zamak - Acero inox
Aluminium - Zamak - Inox

NORMA - STANDARD
NORMA - NORME

EN 1670
EN 1906

FIXAÇÃO - FIXING
FIJACIÓN - FIXATION

Parafusos incluídos
Screws included
Tornillos incluidos
Vis inclus

OBSERVAÇÕES - COMENTS
OBSERVACIONES - OBSERVATIONS

Placa M64/92

MONDIAL



M64/92 (ESQ.)
M64/92 (DRT.)

EMBALAGEM - PACKAGING
EMPAQUETADO - EMBALLAGE

6 pares por caixa
6 pairs per box
6 pares por caja
6 paires par boîte

MATERIAIS - MATERIALS
MATERIALES - MATERIAUX

Alumínio - Zamak - Inox
Aluminium - Zamak - Stainless steel
Aluminio - Zamak - Acero inox
Aluminium - Zamak - Inox

FIXAÇÃO - FIXING
FIJACIÓN - FIXATION

Parafusos incluídos
Screws included
Tornillos incluidos
Vis inclus

ACABAMENTO - FINISHING
ACABADOS - FINITION

Lacado
Powder painting
Lacado
Laqué

NORMA - STANDARD
NORMA - NORME

EN 1670
EN 1906

MULETA C/ MOLA RECUPERAÇÃO · SPRING-LOADED HANDLE FOR DOORS · **MANILLA C/ MUELLE DE RECUPERACIÓN** · BEQUILLE AVEC RESORT DE RAPPEL POUR PORTES

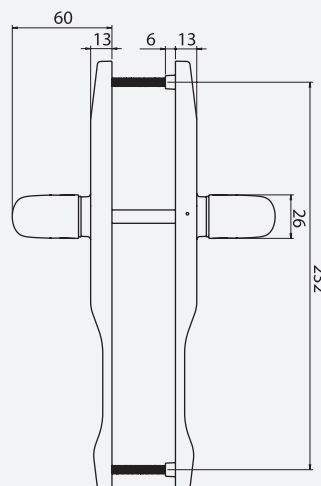
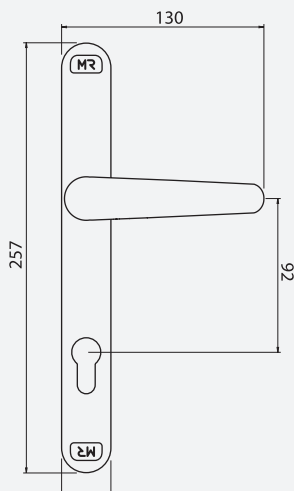

MONDIAL



M64/92 B/B

**M64/92 D/D (ESQ.)
M64/92 D/D (DRT.)**

**EMBALAGEM - PACKAGING
EMPAQUETADO - EMBALLAGE**

6 pares por caixa
6 pairs per box
6 pares por caja
6 paires par boîte

**MATERIAIS - MATERIALS
MATERIALES - MATERIAUX**

Alumínio - Zamak - Inox
Aluminium - Zamak - Stainless steel
Aluminio - Zamak - Acero inox
Aluminium - Zamak - Inox

**FIXAÇÃO - FIXING
FIJACIÓN - FIXATION**

Parafusos incluídos
Screws included
Tornillos incluidos
Vis inclus

**ACABAMENTO - FINISHING
ACABADOS - FINITION**

Lacado
Powder painting
Lacado
Laqué

**NORMA - STANDARD
NORMA - NORME**

EN 1670
EN 1906

MULETA C/ MOLA RECUPERAÇÃO · SPRING-LOADED HANDLE FOR DOORS · MANILLA C/ MUELLE DE RECUPERACIÓN · BEQUILLE AVEC RESORT DE RAPPEL POUR PORTES

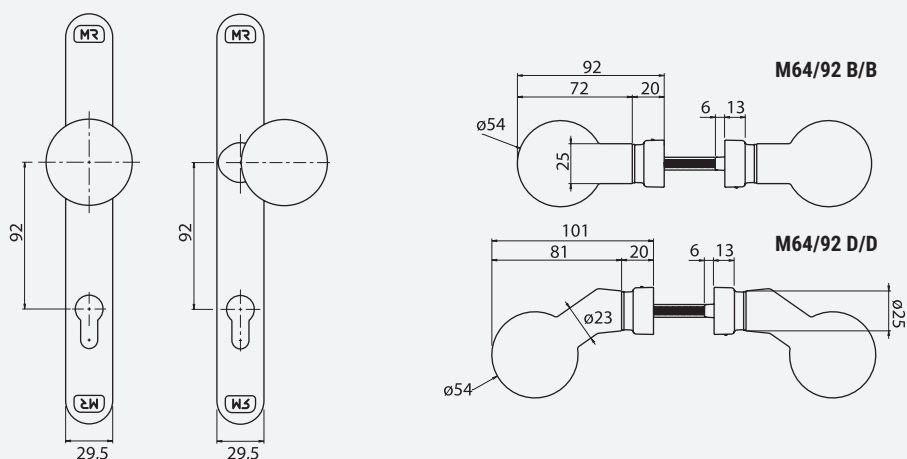

MONDIAL



M70 4POS



M73 4POS

**EMBALAGEM - PACKAGING
EMPAQUETADO - EMBALLAGE**

24 unidades por caixa
24 pieces per box
24 unidades por caja
24 pieces par boîte

**MATERIAIS - MATERIALS
MATERIALES - MATERIAUX**

Alumínio - Zamak - Inox
Aluminium - Zamak - Stainless steel
Aluminio - Zamak - Acero inox
Aluminium - Zamak - Inox

**FIXAÇÃO - FIXING
FIJACIÓN - FIXATION**

Parafusos incluídos
Screws included
Tornillos incluidos
Vis inclus

**ACABAMENTO - FINISHING
ACABADOS - FINITION**

Lacado
Powder painting
Lacado
Laqué

**NORMA - STANDARD
NORMA - NORME**

EN 1670
EN 13126

PUXADOR 4 POSIÇÕES · 4 POSITIONS HANDLE · MANNILLA 4 POSICIONES · BÉQUILLE 4 POSITIONS

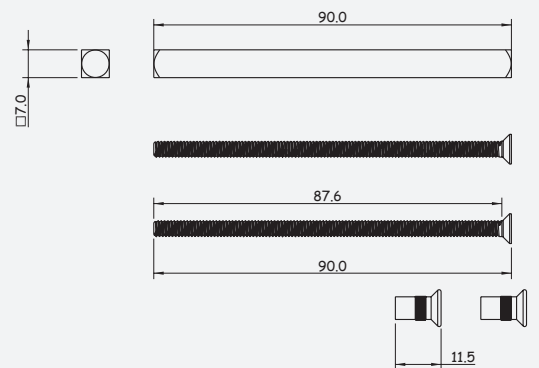
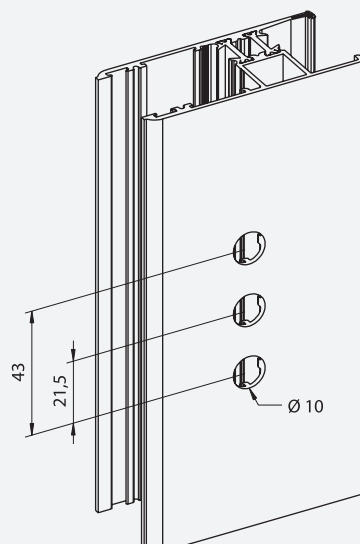
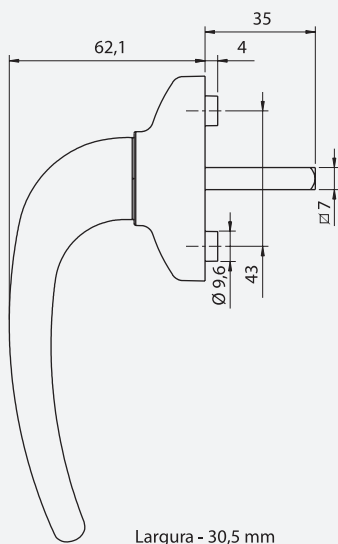

kit duplo M70/M73

5120 1P
5120 C 1P
7100 1P
9530 1P
9530 C 1P
M45
M46

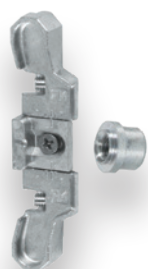

Microventilação Abrir

(cx. 150)

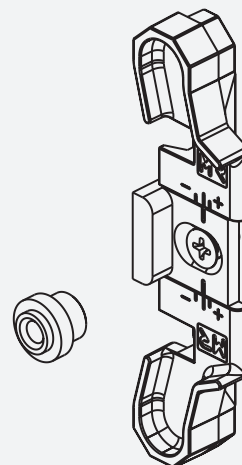

Acionador de Cremone OB 0401

(cx. 250)



MATERIAIS - MATERIALS
MATERIALES - MATERIAUX

Zamak
Zamak
Zamak
Zamak

FIXAÇÃO - FIXING
FIJACIÓN - FIXATION

Parafusos incluídos
Screws included
Tornillos incluidos
Vis inclus

ACABAMENTO - FINISHING
ACABADOS - FINITION

Zincado
Zinc plated
Zincado
Zingué

NORMA - STANDARD
NORMA - NORME

EN 1670
EN 13126

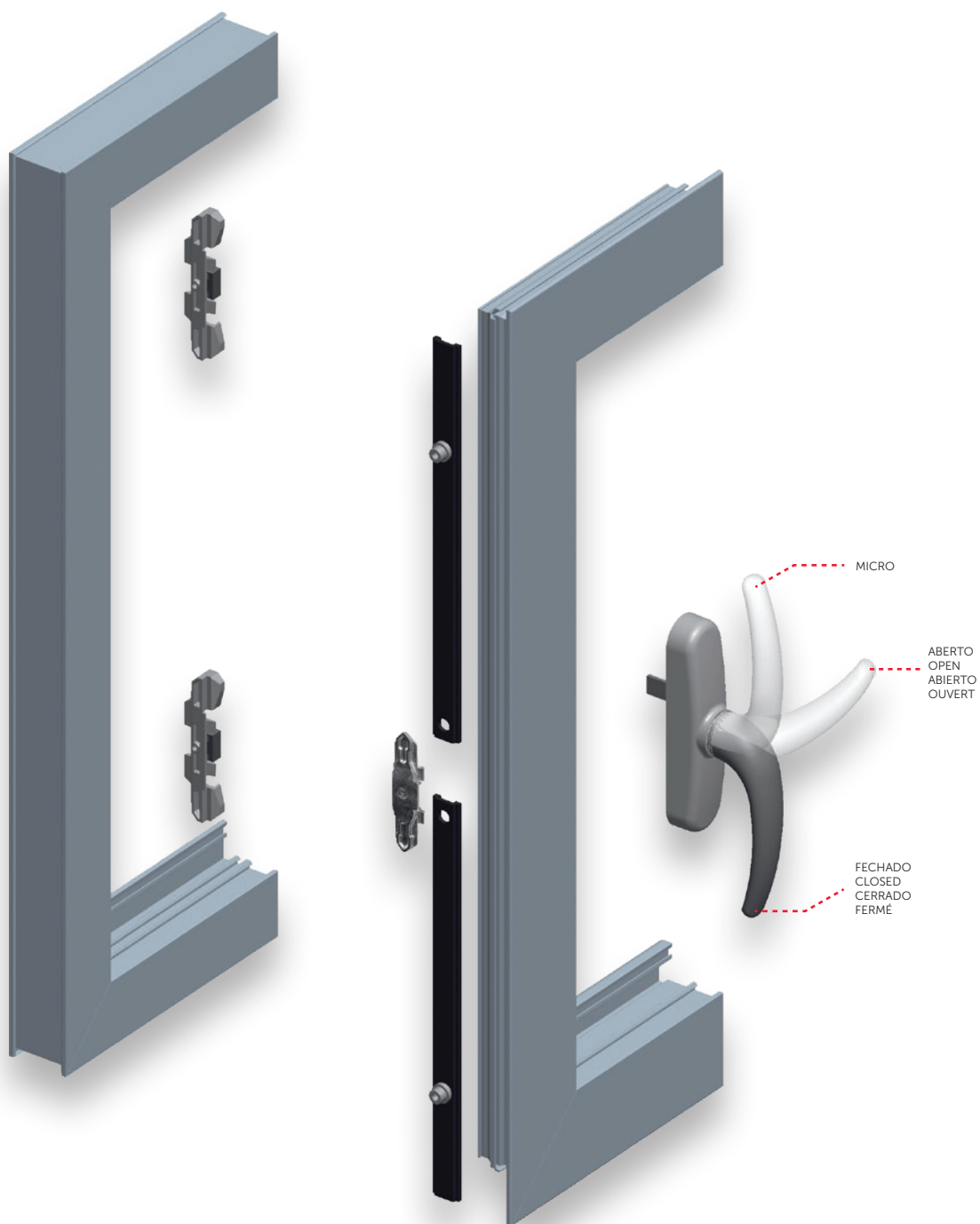



ASSA ABLOY





PRESTIGE



www.mr.pt

PRESTIGE

9530 1P



9530 U



**9530 C 1P
9530 C U**

**EMBALAGEM - PACKAGING
EMPAQUETADO - EMBALLAGE**

12 unidades por caixa
12 pieces per box
12 unidades por caja
12 pieces par boîte

**MATERIAIS - MATERIALS
MATERIALES - MATERIAUX**

Alumínio - Zamak - Inox
Aluminium - Zamak - Stainless steel
Aluminio - Zamak - Acero inox
Aluminium - Zamak - Inox

**FIXAÇÃO - FIXING
FIJACIÓN - FIXATION**

Parafusos incluídos
Screws included
Tornillos incluidos
Vis inclus

**ACABAMENTO - FINISHING
ACABADOS - FINITION**

Lacado
Powder painting
Lacado
Laqué

**NORMA - STANDARD
NORMA - NORME**

EN 1670
EN 13126

**OBSERVAÇÕES - COMMENTS
OBSERVACIONES - OBSERVATIONS**

9530 U
Roleta incluído
Roller included
Rodillo incluido
Rouleaux inclus

CREMONE PARA C. EUROPEIA · CREMONE FOR E.G. SERIES
CREMONA PARA C. EUROPEO · CREMONE POUR C. EUROPÉENNE

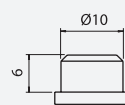
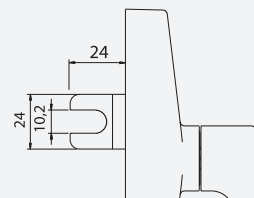
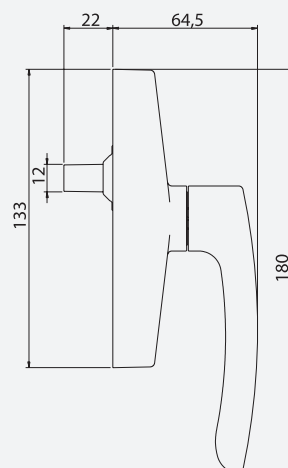
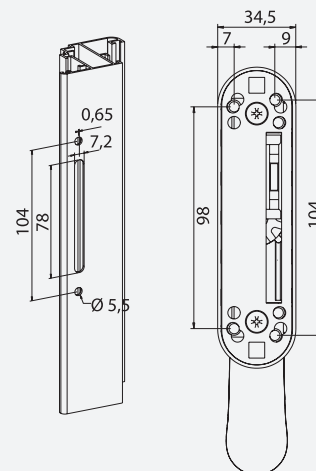

ROLETO

PRESTIGE



9530 D (22)
9530 DC (27)
9530 DC (37)



9530 P1P



9530 P

Pega 9530

EMBALAGEM - PACKAGING
EMPAQUETADO - EMBALLAGE

12 unidades por caixa
12 pieces per box
12 unidades por caja
12 pieces par boîte

MATERIAIS - MATERIALS
MATERIALES - MATERIAUX

Alumínio - Zamak - Inox
Aluminium - Zamak - Stainless steel
Aluminio - Zamak - Acero inox
Aluminium - Zamak - Inox

FIXAÇÃO - FIXING
FIJACIÓN - FIXATION

Parafusos incluídos
Screws included
Tornillos incluidos
Vis inclus

ACABAMENTO - FINISHING
ACABADOS - FINITION

Lacado
Powder painting
Lacado
Laqué

NORMA - STANDARD
NORMA - NORME

EN 1670
EN 13126

OBSERVAÇÕES - COMMENTS
OBSERVACIONES - OBSERVATIONS

PEGA 9530
12 unidades por caixa
12 pieces per box
12 unidades por caja
12 pieces par boîte

CREMONE PARA C. EUROPEIA · CREMONE FOR E.G. SERIES · CREMONA PARA C. EUROPEO · CREMONE POUR C. EUROPÉENNE

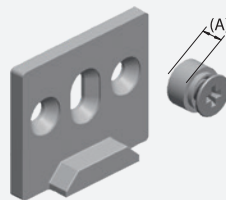
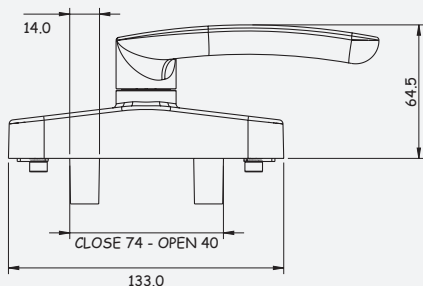
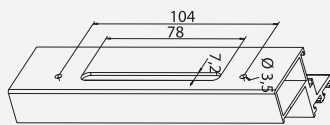
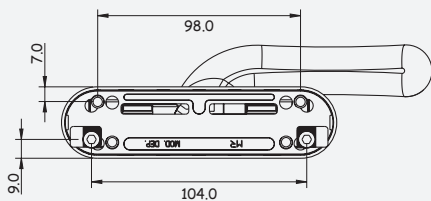

PONTO DE FECHO · CLOSED POINT
PUNTO DE CIELO · POINT FERMÉ

REF. ^a	Tam. (A)
33532	8,5 mm
33533	6,5 mm
	10,5 mm

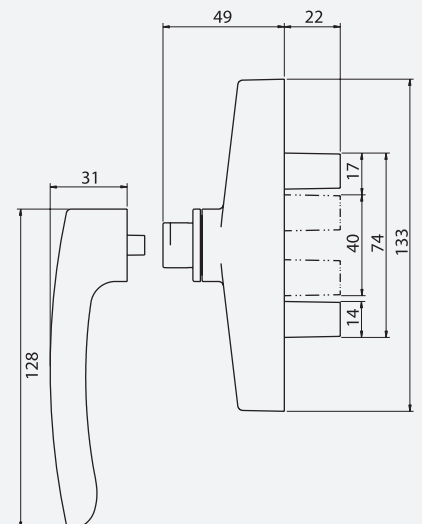

PRESTIGE

9530
9530 (37)(27)



9530 C
9530 C (37)(27)

CREMONE PARA C. EUROPEIA · CREMONE FOR E.G. SERIES
CREMONA PARA C. EUROPEO · CREMONE POUR C. EUROPÉENNE

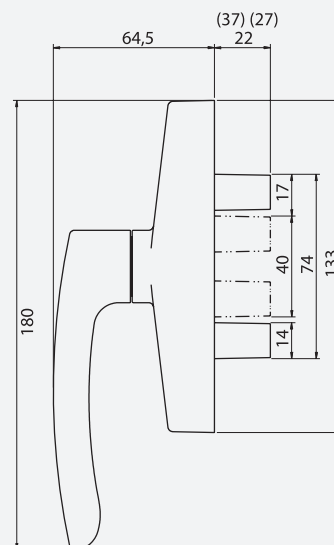
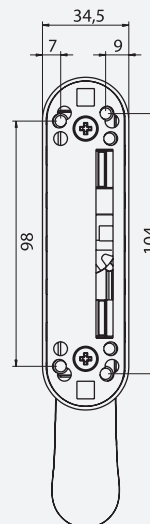

EMBALAGEM - PACKAGING
EMPAQUETADO - EMBALLAGE

12 unidades por caixa
12 pieces per box
12 unidades por caja
12 pieces par boîte

MATERIAIS - MATERIALS
MATERIALES - MATERIAUX

Alumínio - Zamak - Inox
Aluminium - Zamak - Stainless steel
Aluminio - Zamak - Acero inox
Aluminium - Zamak - Inox

FIXAÇÃO - FIXING
FIJACIÓN - FIXATION

Parafusos incluídos
Screws included
Tornillos incluidos
Vis inclus

ACABAMENTO - FINISHING
ACABADOS - FINITION

Lacado
Powder painting
Lacado
Laqué

NORMA - STANDARD
NORMA - NORME

EN 1670
EN 13126

PRESTIGE

9500



9520 P



**Pega
9520**

9520



9520 C

**EMBALAGEM - PACKAGING
EMPAQUETADO - EMBALLAGE**

12 unidades por caixa
12 pieces per box
12 unidades por caja
12 pieces par boîte

**MATERIAIS - MATERIALS
MATERIALES - MATERIAUX**

Alumínio - Zamak - Inox
Aluminium - Zamak - Stainless steel
Aluminio - Zamak - Acero inox
Aluminium - Zamak - Inox

**FIXAÇÃO - FIXING
FIJACIÓN - FIXATION**

Parafusos incluídos
Screws included
Tornillos incluidos
Vis inclus

**ACABAMENTO - FINISHING
ACABADOS - FINITION**

Lacado
Powder painting
Lacado
Laqué

**NORMA - STANDARD
NORMA - NORME**

EN 1670
EN 13126

**OBSERVAÇÕES - COMMENTS
OBSERVACIONES - OBSERVATIONS**

PEGA 9520
12 unidades por caixa
12 pieces per box
12 unidades por caja
12 pieces par boîte

CREMONE COM FIXAÇÃO FRONTAL · CREMONE WITH FRONTAL · FIXATION CREMONA DE FIJACIÓN FRONTAL · CREMONE AVEC FIXATION FRONTALE

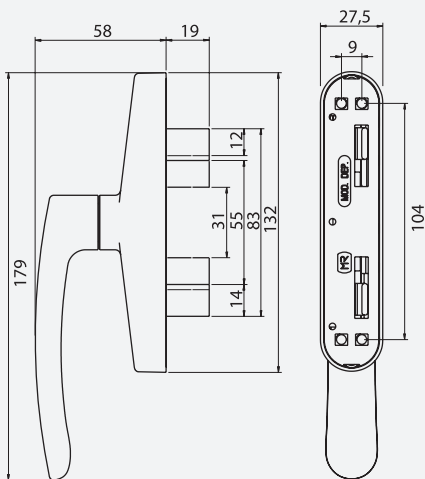

9500

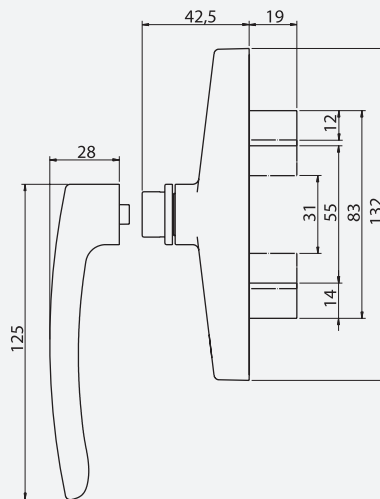

9520 P

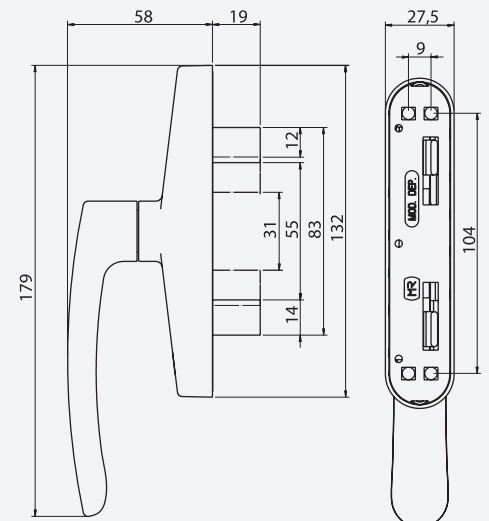

9520 / 9520 C

PRESTIGE

9515



9510



9550



**EMBALAGEM - PACKAGING
EMPAQUETADO - EMBALLAGE**

12 unidades por caixa
12 pieces per box
12 unidades por caja
12 pieces par boite

**MATERIAIS - MATERIALS
MATERIALES - MATERIAUX**

Alumínio - Zamak - Inox
Aluminium - Zamak - Stainless steel
Aluminio - Zamak - Acero inox
Aluminium - Zamak - Inox

**FIXAÇÃO - FIXING
FIJACIÓN - FIXATION**

Parafusos incluídos
Screws included
Tornillos incluidos
Vis inclus

**ACABAMENTO - FINISHING
ACABADOS - FINITION**

Lacado
Powder painting
Lacado
Laqué

**NORMA - STANDARD
NORMA - NORME**

EN 1670
EN 13126

**OBSERVAÇÕES - COMENTS
OBSERVACIONES - OBSERVATIONS**

9515
pat. transm. pequena = 19mm
pat. transm. grande = 22mm

CREMONE COM FIXAÇÃO FRONTAL · CREMONE WITH FRONTAL · FIXATION CREMONA DE FIJACIÓN FRONTAL · CREMONE AVEC FIXATION FRONTALE

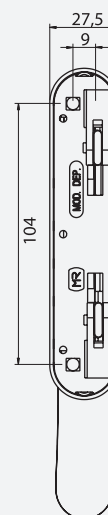
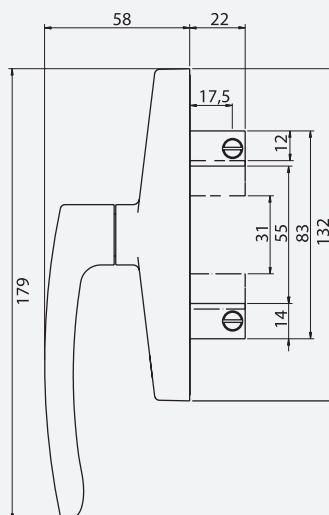
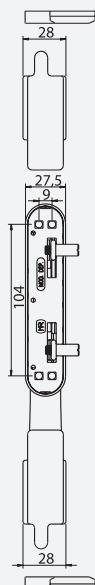

CREMONE ABERTURA EXTERIOR
CREMONE OUTWARDS OPENING
CREMONA APERTURA EXTERIOR
CREMONE OUVERTURE EXTERIEUR

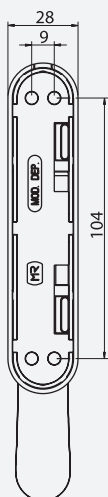
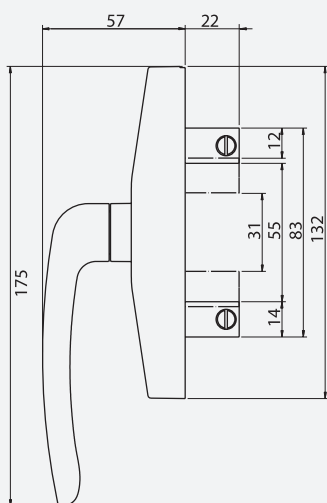
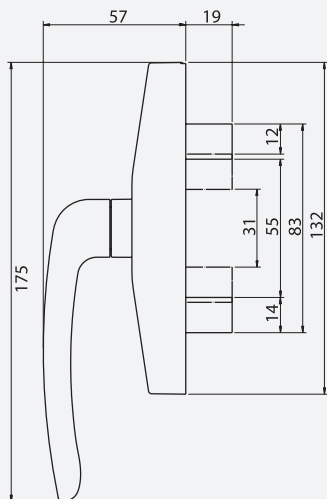

MR2006



MR2007

EMBALAGEM - PACKAGING
EMPAQUETADO - EMBALLAGE

12 unidades por caixa
12 pieces per box
12 unidades por caja
12 pieces par boîte

MATERIAIS - MATERIALS
MATERIALES - MATERIAUX

Alumínio - Zamak - Inox
Aluminium - Zamak - Stainless steel
Aluminio - Zamak - Acero inox
Aluminium - Zamak - Inox

FIXAÇÃO - FIXING
FIJACIÓN - FIXATION

Parafusos incluídos
Screws included
Tornillos incluidos
Vis inclus

ACABAMENTO - FINISHING
ACABADOS - FINITION

Lacado
Powder painting
Lacado
Laqué

NORMA - STANDARD
NORMA - NORME

EN 1670
EN 13126

OBSERVAÇÕES - COMMENTS
OBSERVACIONES - OBSERVATIONS

MR2007
pat. transmissão grande = 22mm

PRESTIGE

MR2008



**Ponto fecho CE
MR2008**

**EMBALAGEM - PACKAGING
EMPAQUETADO - EMBALLAGE**

12 unidades por caixa
12 pieces per box
12 unidades por caja
12 pieces par boîte

**MATERIAIS - MATERIALS
MATERIALES - MATERIAUX**

Alumínio - Zamak - Inox
Aluminium - Zamak - Stainless steel
Aluminio - Zamak - Acero inox
Aluminium - Zamak - Inox

**FIXAÇÃO - FIXING
FIJACIÓN - FIXATION**

Parafusos incluídos
Screws included
Tornillos incluidos
Vis inclus

**ACABAMENTO - FINISHING
ACABADOS - FINITION**

Lacado
Powder painting
Lacado
Laqué

**NORMA - STANDARD
NORMA - NORME**

EN 1670
EN 13126

**OBSERVAÇÕES - COMMENTS
OBSERVACIONES - OBSERVATIONS**

**Ponto fecho CE
MR2008**
50 unidades por caixa
50 pieces per box
50 unidades por caja
50 pieces par boîte

CREMONE ABERTURA EXTERIOR · CREMONE OUTWARDS OPENING · CREMONA APERTURA EXTERIOR · CREMONE OUVERTURE EXTERIEUR

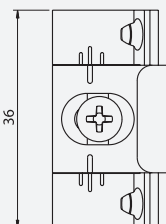
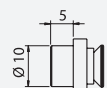
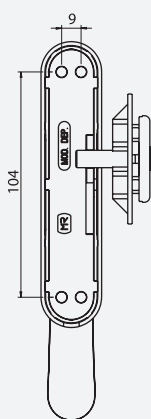

**Ponto fecho CE
MR2008**

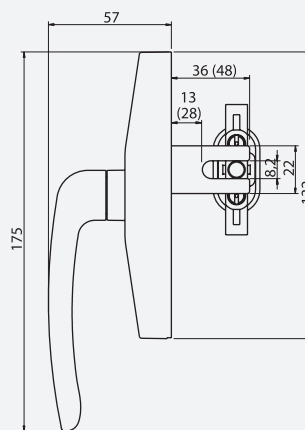

**MR2008/36
MR2008/48**

MULETA C/ MOLA RECUPERAÇÃO
SPRING-LOADED HANDLE FOR DOORS
MANILLA C/ MUELLE DE RECUPERACIÓN
BÉQUILLE AVEC RESORT DE RAPPEL POUR PORTES

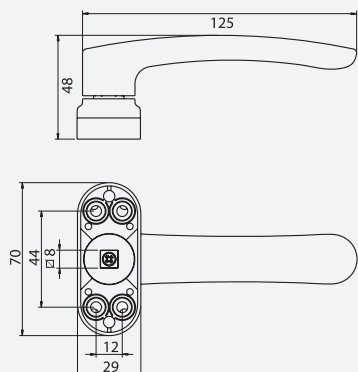

9570

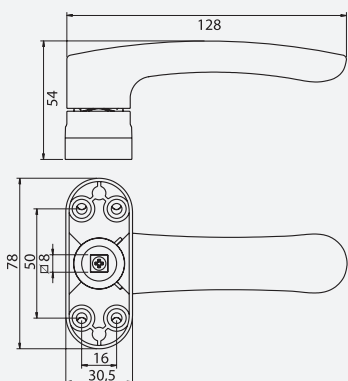

9580

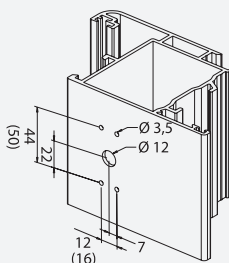

PRESTIGE

9570



9580



EMBALAGEM - PACKAGING
EMPAQUETADO - EMBALLAGE

12 pares por caixa
12 pairs per box
12 pares por caja
12 paires par boîte

MATERIAIS - MATERIALS
MATERIALES - MATERIAUX

Alumínio - Zamak - Inox
Aluminium - Zamak - Stainless steel
Aluminio - Zamak - Acero inox
Aluminium - Zamak - Inox

FIXAÇÃO - FIXING
FIJACIÓN - FIXATION

Parafusos incluídos
Screws included
Tornillos incluidos
Vis inclus

ACABAMENTO - FINISHING
ACABADOS - FINITION

Lacado
Powder painting
Lacado
Laqué

NORMA - STANDARD
NORMA - NORME

EN 1670
EN 1906

PRESTIGE

9575



MULETA C/ MOLA RECUPERAÇÃO
SPRING-LOADED HANDLE FOR DOORS
MANILLA C/ MUELLE DE RECUPERACIÓN
BÉQUILLE AVEC RESORT DE RAPPEL POUR PORTES

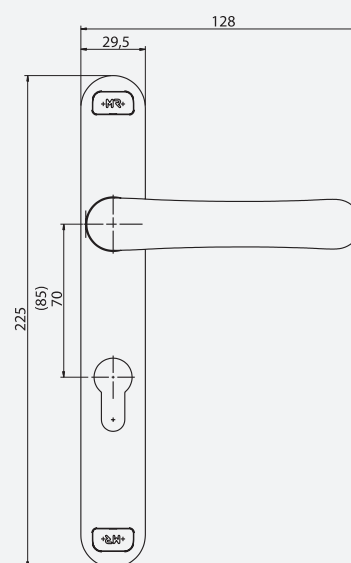
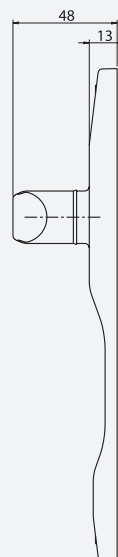

EMBALAGEM - PACKAGING
EMPAQUETADO - EMBALLAGE

6 pares por caixa
6 pairs per box
6 pares por caja
6 paires par boîte

MATERIAIS - MATERIALS
MATERIALES - MATERIAUX

Alumínio - Zamak - Inox
Aluminium - Zamak - Stainless steel
Aluminio - Zamak - Acero inox
Aluminium - Zamak - Inox

FIXAÇÃO - FIXING
FIJACIÓN - FIXATION

Parafusos incluídos
Screws included
Tornillos incluidos
Vis inclus

ACABAMENTO - FINISHING
ACABADOS - FINITION

Lacado
Powder painting
Lacado
Laqué

NORMA - STANDARD
NORMA - NORME

EN 1670
EN 1906

PRESTIGE



9576/92 (ESQ.)
9576/92 (DIR.)



9570 D/D



9570 B/B

EMBALAGEM - PACKAGING
EMPAQUETADO - EMBALLAGE

9570 D/D - B/B
12 pares por caixa
12 pairs per box
12 pares por caja
12 paires par boîte

MATERIAIS - MATERIALS
MATERIALES - MATERIAUX

Alumínio - Zamak - Inox
Aluminium - Zamak - Stainless steel
Aluminio - Zamak - Acero inox
Aluminium - Zamak - Inox

FIXAÇÃO - FIXING
FIJACIÓN - FIXATION

Parafusos incluídos
Screws included
Tornillos incluidos
Vis inclus

ACABAMENTO - FINISHING
ACABADOS - FINITION

Lacado
Powder painting
Lacado
Laqué

NORMA - STANDARD
NORMA - NORME

EN 1670
EN 1906

OBSERVAÇÕES - COMENTS
OBSERVACIONES - OBSERVATIONS

9576/92
6 pares por caixa
6 pairs per box
6 pares por caja
6 paires par boîte

MULETA C/ MOLA RECUPERAÇÃO · SPRING-LOADED HANDLE FOR DOORS · MANILLA C/ MUELLE DE RECUPERACIÓN · BÉQUILLE AVEC RESORT DE RAPPEL POUR PORTES

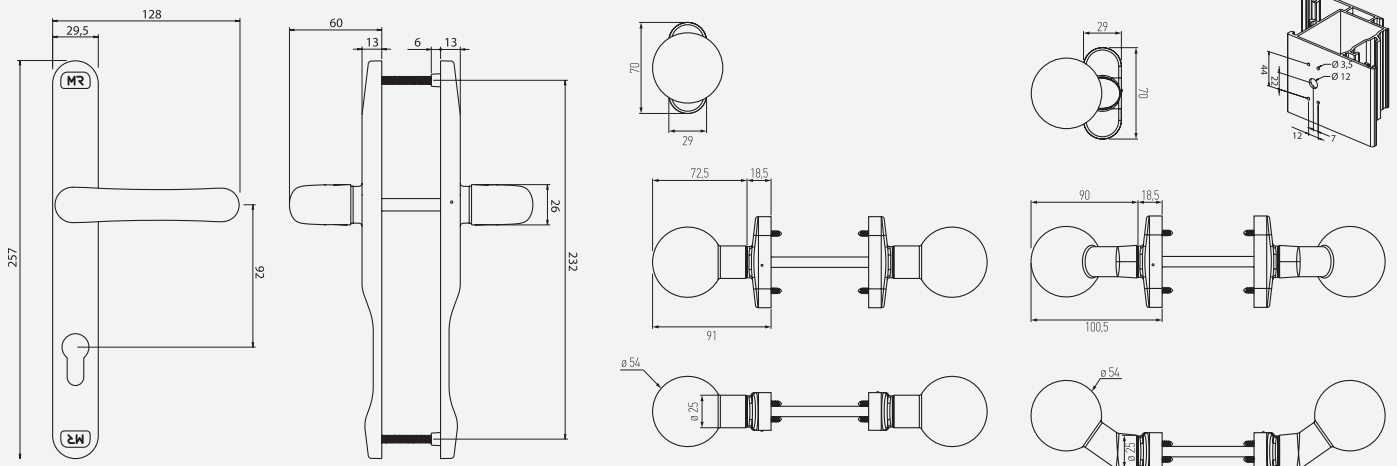

PRESTIGE

9630



9620



9600



9625



EMBALAGEM - PACKAGING
EMPAQUETADO - EMBALLAGE

24 unidades por caixa
24 pieces per box
24 unidades por caja
24 pieces par boîte

MATERIAIS - MATERIALS
MATERIALES - MATERIAUX

Alumínio - Zamak - Inox
Aluminium - Zamak - Stainless steel
Aluminio - Zamak - Acero inox
Aluminium - Zamak - Inox

FIXAÇÃO - FIXING
FIJACIÓN - FIXATION

Parafusos incluídos
Screws included
Tornillos incluidos
Vis inclus

ACABAMENTO - FINISHING
ACABADOS - FINITION

Lacado
Powder painting
Lacado
Laqué

NORMA - STANDARD
NORMA - NORME

EN 1670
EN 13126

PUXADOR 4 POSIÇÕES · 4 POSITIONS HANDLE · MANNILLA 4 POSICIONES · BÉQUILLE 4 POSITIONS

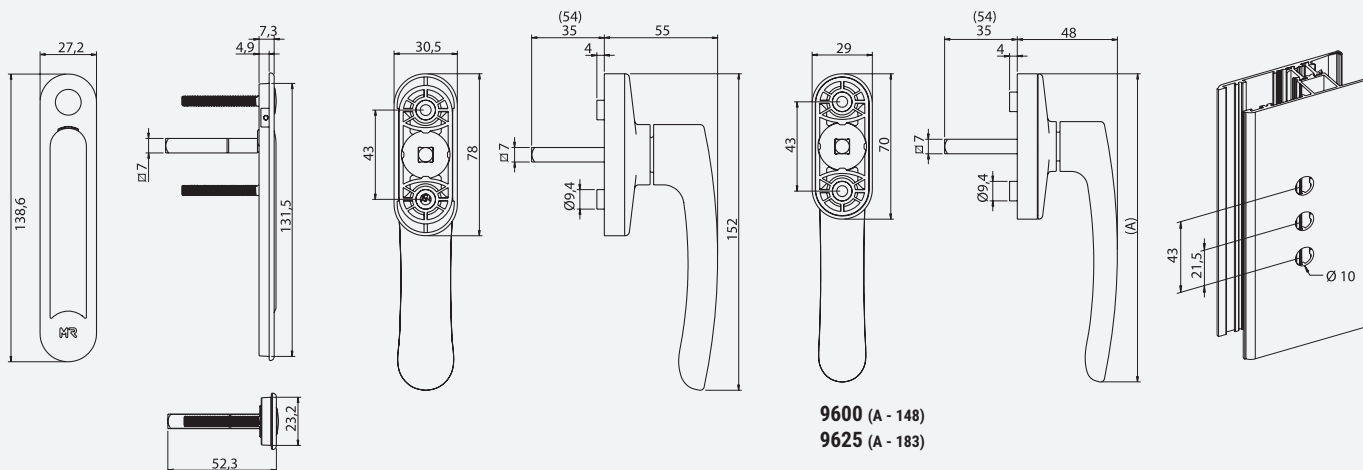

PRESTIGE

9636 ESQ



9635 DIR



**EMBALAGEM - PACKAGING
EMPAQUETADO - EMBALLAGE**

24 unidades por caixa
24 pieces per box
24 unidades por caja
24 pieces par boîte

**MATERIAIS - MATERIALS
MATERIALES - MATERIAUX**

Alumínio - Zamak - Inox
Aluminium - Zamak - Stainless steel
Aluminio - Zamak - Acero inox
Aluminium - Zamak - Inox

**FIXAÇÃO - FIXING
FIJACIÓN - FIXATION**

Parafusos incluídos
Screws included
Tornillos incluidos
Vis inclus

**ACABAMENTO - FINISHING
ACABADOS - FINITION**

Lacado
Powder painting
Lacado
Laqué

**NORMA - STANDARD
NORMA - NORME**

EN 1670
EN 13126

PUXADOR 4 POSIÇÕES · 4 POSITIONS HANDLE · MANNILLA 4 POSICIONES · BÉQUILLE 4 POSITIONS

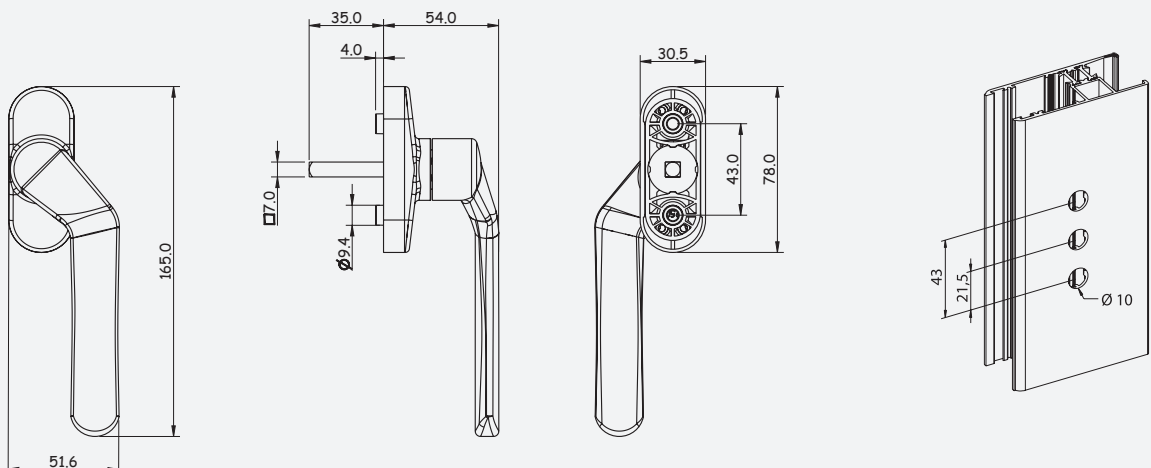

PRESTIGE

9565



9560



9561

EMBALAGEM - PACKAGING
EMPAQUETADO - EMBALLAGE

24 unidades por caixa
24 pieces per box
24 unidades por caixa
24 pieces par boîte

MATERIAIS - MATERIALS
MATERIALES - MATERIAUX

Alumínio - Zamak - Inox
Aluminium - Zamak - Stainless steel
Aluminio - Zamak - Acero inox
Aluminium - Zamak - Inox

FIXAÇÃO - FIXING
FIJACIÓN - FIXATION

Parafusos incluídos
Screws included
Tornillos incluidos
Vis inclus

ACABAMENTO - FINISHING
ACABADOS - FINITION

Lacado
Powder painting
Lacado
Laqué

NORMA - STANDARD
NORMA - NORME

EN 1670
EN 13126

OBSERVAÇÕES - COMMENTS
OBSERVACIONES - OBSERVATIONS

9561 = 66mm
9560/9561
Inclui Ressalto Batente
1,2mm e 3mm, não inclui
calço de 3 e 5 mm

TRINQUETA REVERSÍVEL · REVERSIBLE CLOSING HANDLE · CIERRE DE PRESIÓN · POIGNÉE ANGLAISE

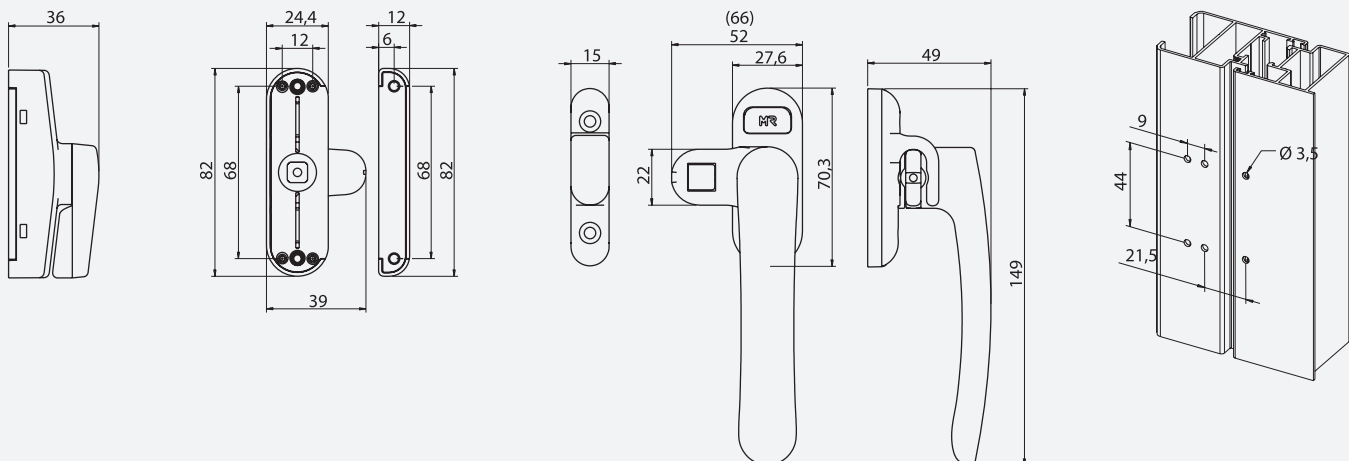

PRESTIGE

MR 480



**EMBALAGEM - PACKAGING
EMPAQUETADO - EMBALLAGE**

24 unidades por caixa
24 pieces per box
24 unidades por caja
24 pieces par boîte

**MATERIAIS - MATERIALS
MATERIALES - MATERIAUX**

Alumínio - Zamak - Inox
Aluminium - Zamak - Stainless steel
Aluminio - Zamak - Acero inox
Aluminium - Zamak - Inox

**FIXAÇÃO - FIXING
FIJACIÓN - FIXATION**

Parafusos incluídos
Screws included
Tornillos incluidos
Vis inclus

**ACABAMENTO - FINISHING
ACABADOS - FINITION**

Lacado
Powder painting
Lacado
Laqué

**NORMA - STANDARD
NORMA - NORME**

EN 1670
EN 13126

**OBSERVAÇÕES - COMMENTS
OBSERVACIONES - OBSERVATIONS**

Esquerdo / Direito
Left / Right
Izquierda / Derecha
Gauche / Droite

PUXADOR ESQ./DIR. · LEFT/RIGHT HANDLE · MANNILLA IZQUIERDA/DERECHA · BÉQUILLE GAUCHE/DROITE

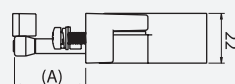
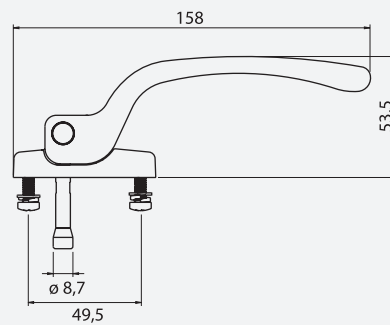
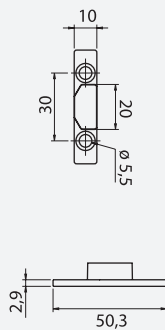
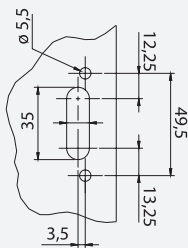

(A)
24,5
28,5
32



ASSA ABLOY





MR

www.mr.pt



7100 1P



7100

**EMBALAGEM - PACKAGING
EMPAQUETADO - EMBALLAGE**

12 unidades por caixa
12 pieces per box
12 unidades por caja
12 pieces par boîte

**MATERIAIS - MATERIALS
MATERIALES - MATERIAUX**

Alumínio - Zamak - Inox
Aluminium - Zamak - Stainless steel
Aluminio - Zamak - Acero inox
Aluminium - Zamak - Inox

**FIXAÇÃO - FIXING
FIJACIÓN - FIXATION**

Parafusos incluídos
Screws included
Tornillos incluidos
Vis inclus

**ACABAMENTO - FINISHING
ACABADOS - FINITION**

Lacado
Powder painting
Lacado
Laqué

**NORMA - STANDARD
NORMA - NORME**

EN 1670
EN 13126

**OBSERVAÇÕES - COMMENTS
OBSERVACIONES - OBSERVATIONS**

Roletó incluído
Roller included
Rodillo incluído
Rouleaux inclus

CREMONE PARA C. EUROPEIA · CREMONE FOR E.G. SERIES · CREMONA PARA C. EUROPEO · CREMONE POUR C. EUROPÉENNE

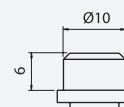
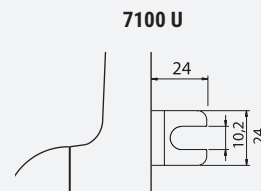
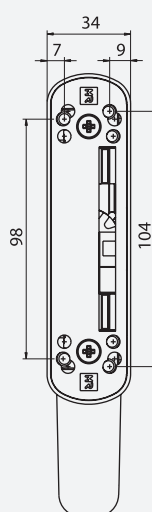
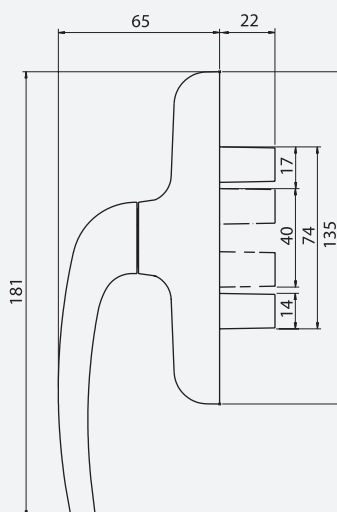
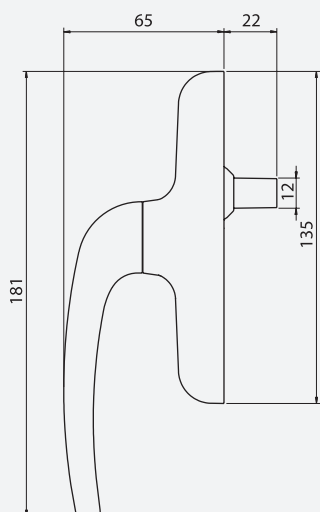

ROLETO

CREMONE PARA C. EUROPEIA
CREMONE FOR E.G. SERIES
CREMONA PARA C. EUROPEO
CREMONE POUR C. EUROPÉENNE

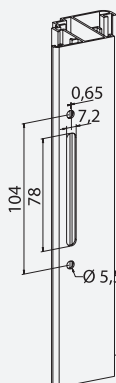
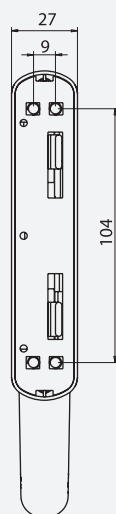
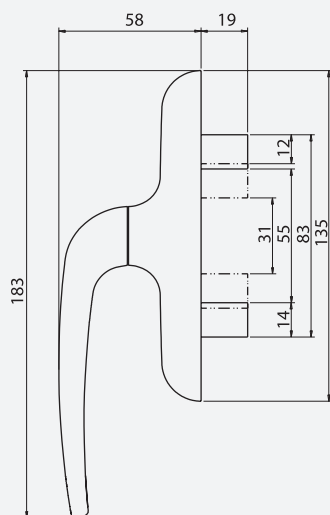

EMBALAGEM - PACKAGING
EMPAQUETADO - EMBALLAGE

12 unidades por caixa
12 pieces per box
12 unidades por caja
12 pieces par boîte

ACABAMENTO - FINISHING
ACABADOS - FINITION

Lacado
Powder painting
Lacado
Laqué

MATERIAIS - MATERIALS
MATERIALES - MATERIAUX

Alumínio - Zamak - Inox
Aluminium - Zamak - Stainless steel
Aluminio - Zamak - Acero inox
Aluminium - Zamak - Inox

NORMA - STANDARD
NORMA - NORME

EN 1670
EN 13126

FIXAÇÃO - FIXING
FIJACIÓN - FIXATION

Parafusos incluídos
Screws included
Tornillos incluidos
Vis inclus



6101



6100

**EMBALAGEM - PACKAGING
EMPAQUETADO - EMBALLAGE**

12 unidades por caixa
12 pieces per box
12 unidades por caixa
12 pieces par boîte

**MATERIAIS - MATERIALS
MATERIALES - MATERIAUX**

Alumínio - Zamak - Inox
Aluminium - Zamak - Stainless steel
Aluminio - Zamak - Acero inox
Aluminium - Zamak - Inox

**FIXAÇÃO - FIXING
FIJACIÓN - FIXATION**

Parafusos incluídos
Screws included
Tornillos incluidos
Vis inclus

**ACABAMENTO - FINISHING
ACABADOS - FINITION**

Lacado
Powder painting
Lacado
Laqué

**NORMA - STANDARD
NORMA - NORME**

EN 1670
EN 13126

**OBSERVAÇÕES - COMMENTS
OBSERVACIONES - OBSERVATIONS**

6101
- pat. transm. pequena = 19mm
- pat. transm. grande = 22mm

CREMONE COM FIXAÇÃO FRONTAL · CREMONE WITH FRONTAL FIXATION · CREMONA DE FIJACIÓN FRONTAL · CREMONE AVEC FIXATION FRONTALE

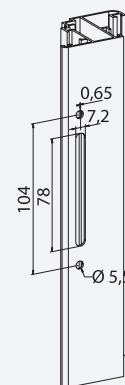
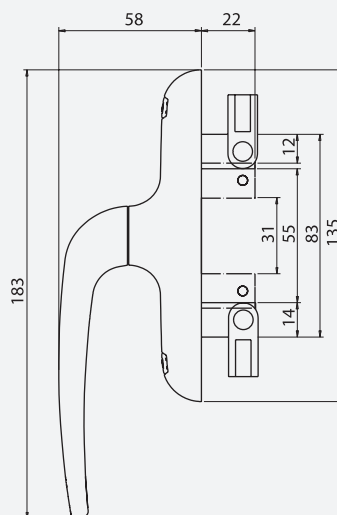
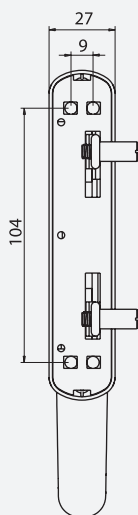
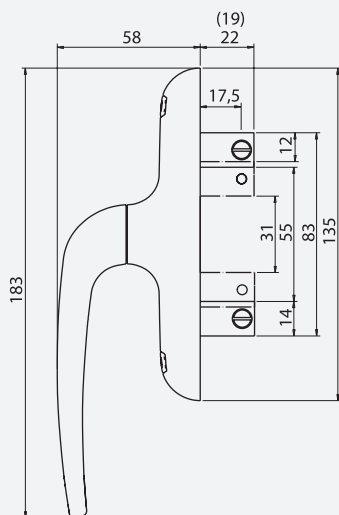



6150



6200

EMBALAGEM - PACKAGING
EMPAQUETADO - EMBALLAGE

12 unidades por caixa
12 pieces per box
12 unidades por caja
12 pieces par boîte

MATERIAIS - MATERIALS
MATERIALES - MATERIAUX

Alumínio - Zamak - Inox
Aluminium - Zamak - Stainless steel
Aluminio - Zamak - Acero inox
Aluminium - Zamak - Inox

FIXAÇÃO - FIXING
FIJACIÓN - FIXATION

Parafusos incluídos
Screws included
Tornillos incluidos
Vis inclus

ACABAMENTO - FINISHING
ACABADOS - FINITION

Lacado
Powder painting
Lacado
Laqué

NORMA - STANDARD
NORMA - NORME

EN 1670
EN 13126

CREMONE COM FIXAÇÃO FRONTAL · CREMONE WITH FRONTAL FIXATION · CREMONA DE FIJACIÓN FRONTAL · CREMONE AVEC FIXATION FRONTALE

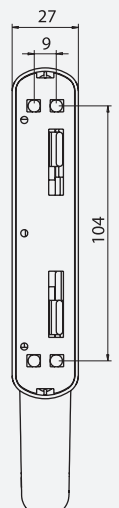
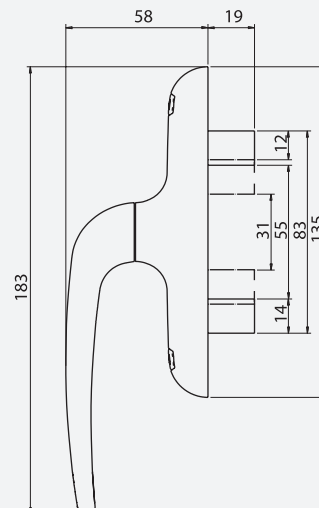
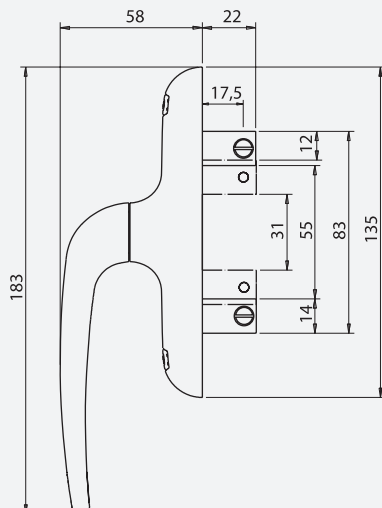
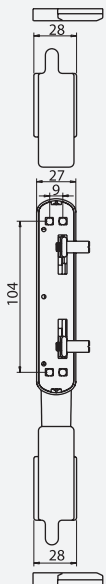



6302
6303



6301



6300

EMBALAGEM - PACKAGING
EMPAQUETADO - EMBALLAGE

12 unidades por caixa
12 pieces per box
12 unidades por caja
12 pieces par boîte

MATERIAIS - MATERIALS
MATERIALES - MATERIAUX

Alumínio - Zamak - Inox
Aluminium - Zamak - Stainless steel
Aluminio - Zamak - Acero inox
Aluminium - Zamak - Inox

FIXAÇÃO - FIXING
FIJACIÓN - FIXATION

Parafusos incluídos
Screws included
Tornillos incluidos
Vis inclus

ACABAMENTO - FINISHING
ACABADOS - FINITION

Lacado
Powder painting
Lacado
Laqué

NORMA - STANDARD
NORMA - NORME

EN 1670
EN 13126

OBSERVAÇÕES - COMMENTS
OBSERVACIONES - OBSERVATIONS

6302
- pat. transmissão = 22mm
6303
- pat. transmissão = 19mm

CREMONE ROTATIVO BAIXO · ROTATE LOW CREMONE · CREMONA ROTATIVA BAJA · CREMONE ROTATIF POSITION BASSE

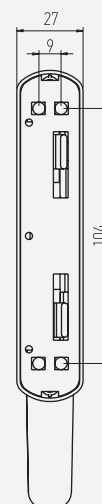
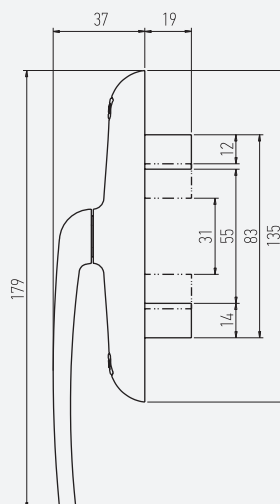
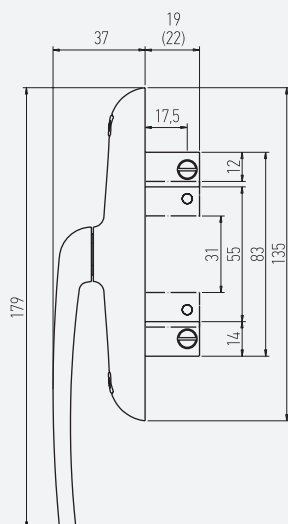

MULETA C/ MOLA RECUPERAÇÃO
SPRING-LOADED HANDLE FOR DOORS
MANILLA C/ MUELLE DE RECUPERACIÓN
BÉQUILLE AVEC RESORT DE RAPPEL POUR PORTES

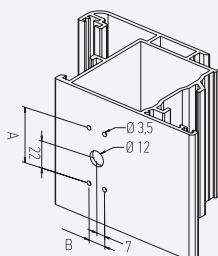
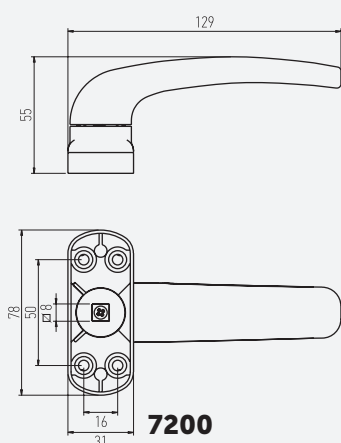
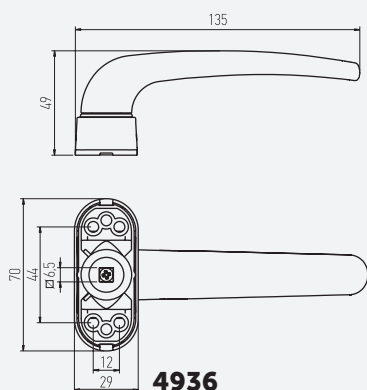

ref.ª	(A)	(B)
4936	44 mm	12 mm
7200	50 mm	16 mm



4936



7200

EMBALAGEM - PACKAGING
EMPAQUETADO - EMBALLAGE

12 pares por caixa
12 pairs per box
12 pares por caja
12 paires par boîte

MATERIAIS - MATERIALS
MATERIALES - MATERIAUX

Alumínio - Zamak - Inox
Aluminium - Zamak - Stainless steel
Aluminio - Zamak - Acero inox
Aluminium - Zamak - Inox

FIXAÇÃO - FIXING
FIJACIÓN - FIXATION

Parafusos incluídos
Screws included
Tornillos incluidos
Vis inclus

ACABAMENTO - FINISHING
ACABADOS - FINITION

Lacado
Powder painting
Lacado
Laqué

NORMA - STANDARD
NORMA - NORME

EN 1670
EN 1906

MR



936



4930

EMBALAGEM - PACKAGING
EMPAQUETADO - EMBALLAGE

12 pares por caixa
12 pairs per box
12 pares por caja
12 paires par boîte

MATERIAIS - MATERIALS
MATERIALES - MATERIAUX

Alumínio - Zamak - Inox
Aluminium - Zamak - Stainless steel
Aluminio - Zamak - Acero inox
Aluminium - Zamak - Inox

FIXAÇÃO - FIXING
FIJACIÓN - FIXATION

Parafusos incluídos
Screws included
Tornillos incluidos
Vis inclus

ACABAMENTO - FINISHING
ACABADOS - FINITION

Lacado
Powder painting
Lacado
Laqué

NORMA - STANDARD
NORMA - NORME

EN 1670
EN 1906

OBSERVAÇÕES - COMMENTS
OBSERVACIONES - OBSERVATIONS

4930
24 unidades por caixa
24 pieces per box
24 unidades por caja
24 pieces par boîte

MULETA C/ MOLA RECUPERAÇÃO · SPRING-LOADED HANDLE FOR DOORS · MANILLA C/ MUELLE DE RECUPERACIÓN · BÉQUILLE AVEC RESORT DE RAPPEL POUR PORTES

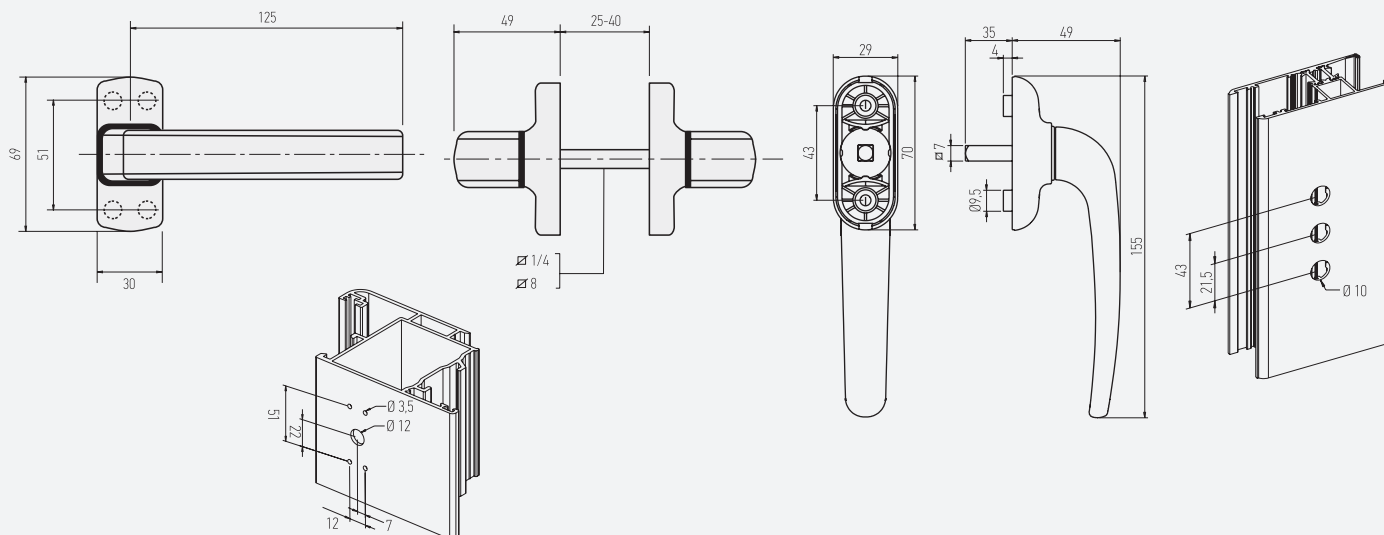

TRINQUETA REVERSÍVEL
REVERSIBLE CLOSING HANDLE
CIERRE DE PRESIÓN
POIGNÉE ANGLAISE



Ressalto Batente
3mm



Ressalto Batente
1,2mm



Ressalto*
5mm



Ressalto*
3mm

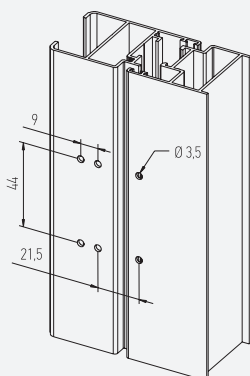
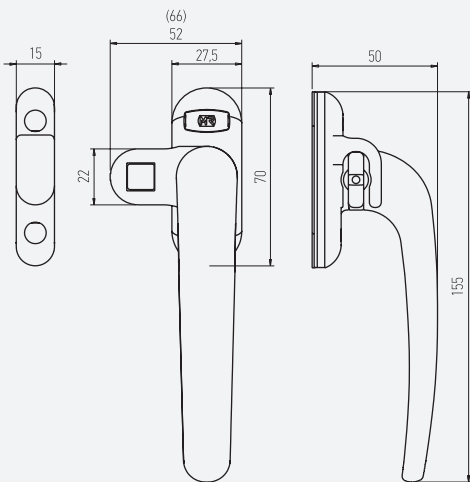

4940



4941

EMBALAGEM - PACKAGING
EMPAQUETADO - EMBALLAGE

24 unidades por caixa
24 pieces per box
24 unidades por caja
24 pieces par boîte

MATERIAIS - MATERIALS
MATERIALES - MATERIAUX

Alumínio - Zamak - Nylon
Aluminium - Zamak - Nylon
Aluminio - Zamak - Nylon
Aluminium - Zamak - Nylon

FIXAÇÃO - FIXING
FIJACIÓN - FIXATION

Parafusos incluídos
Screws included
Tornillos incluídos
Vis inclus

ACABAMENTO - FINISHING
ACABADOS - FINITION

Lacado
Powder painting
Lacado
Laqué

NORMA - STANDARD
NORMA - NORME

EN 1670
EN 13126

OBSERVAÇÕES - COMMENTS
OBSERVACIONES - OBSERVATIONS

4941 = 66mm
* não incluídos · not included
no incluido · non include



ASSA ABLOY

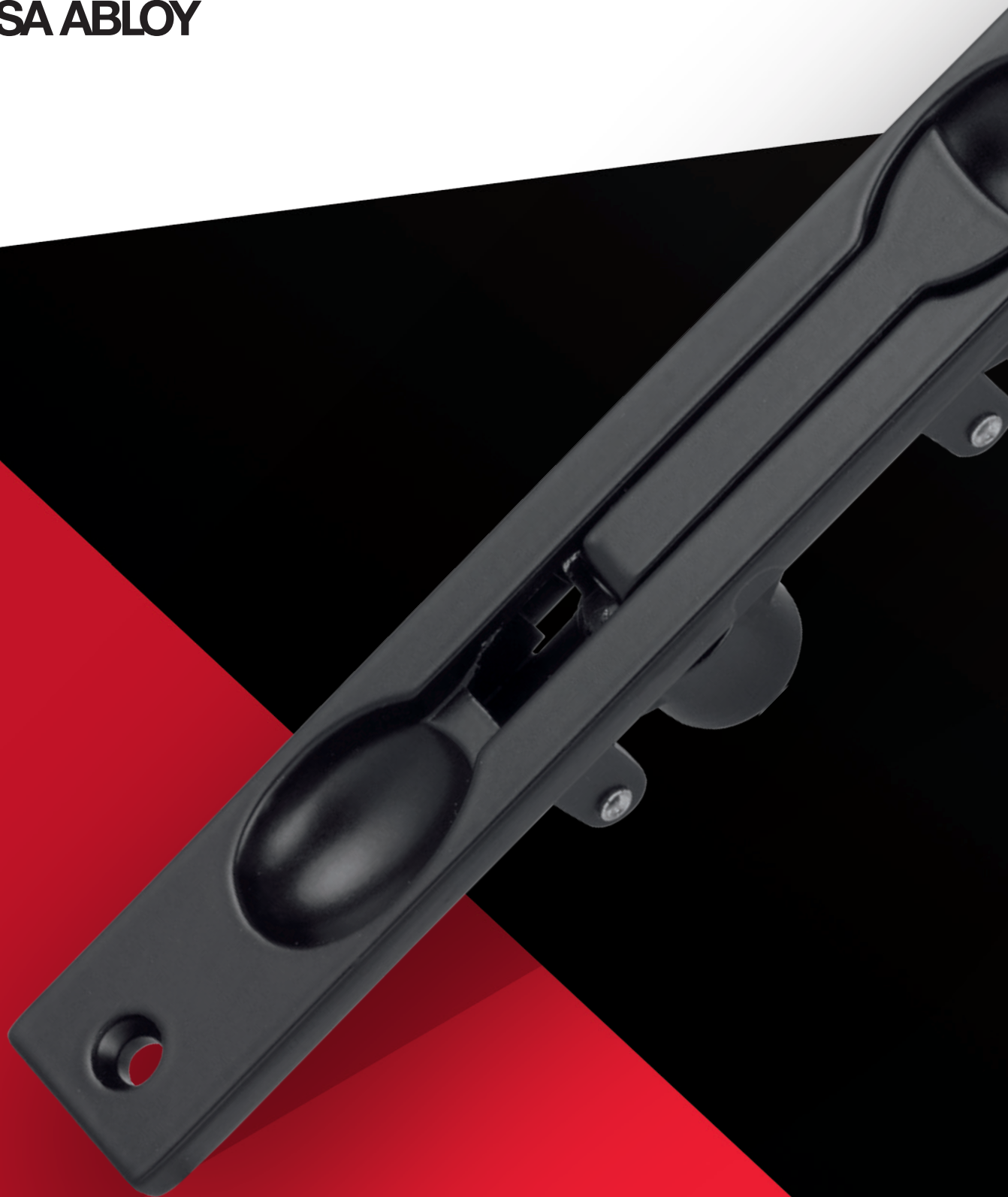



KITS E FECHOS

KITS AND LOCKS

KITS Y CIERRES

KITS ET LOQUETEAUX



9212

EMBALAGEM - PACKAGING
EMPAQUETADO - EMBALLAGE

24 unidades por caixa
24 pieces per box
24 unidades por caja
24 pieces par boîte

MATERIAIS - MATERIALS
MATERIALES - MATERIAUX

Alumínio - Zamak - Nylon - Inox
Aluminium - Zamak - Nylon - Stainless steel
Aluminio - Zamak - Nylon - Acero inox
Aluminium - Zamak - Nylon - Inox

FIXAÇÃO - FIXING
FIJACIÓN - FIXATION

Parafusos incluídos
Screws included
Tornillos incluidos
Vis inclus

ACABAMENTO - FINISHING
ACABADOS - FINITION

Lacado
Powder painting
Lacado
Laqué

NORMA - STANDARD
NORMA - NORME

EN 1670

FECHO BI-DIRECCIONAL · TWO WAY SHOOTBOLT LEVER · PASADOR DE PALANCA BIDIRECCIONAL · VERROU À LEVIER BIDIRECTIONNEL

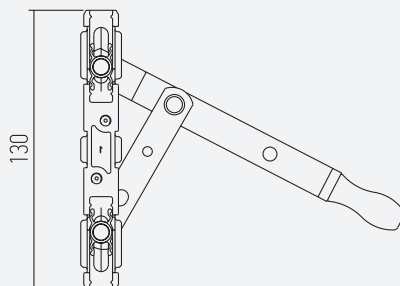
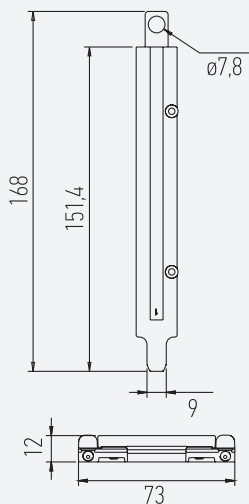



TESTA INOX

40.20

EMBALAGEM - PACKAGING
EMPAQUETADO - EMBALLAGE

40.20:
50 unidades por caixa
50 pieces per box
50 unidades por caja
50 pieces par boite

TESTA INOX:
300 unidades por caixa
300 pieces per box
300 unidades por caja
300 pieces par boite

MATERIAIS - MATERIALS
MATERIALES - MATERIAUX

Alumínio - Zamak - Inox
Aluminium - Zamak - Stainless steel
Aluminio - Zamak - Acero inox
Aluminium - Zamak - Inox

FIXAÇÃO - FIXING
FIJACIÓN - FIXATION

Parafusos incluídos
Screws included
Tornillos incluidos
Vis inclus

ACABAMENTO - FINISHING
ACABADOS - FINITION

Lacado
Powder painting
Lacado
Laqué

NORMA - STANDARD
NORMA - NORME

EN 1670

FECHO PARA C. EUROPEIA · LOCK FOR E.G. SERIES · CIERRE PARA C. EUROPEO · VERROUS POUR C. EUROPÉENNE

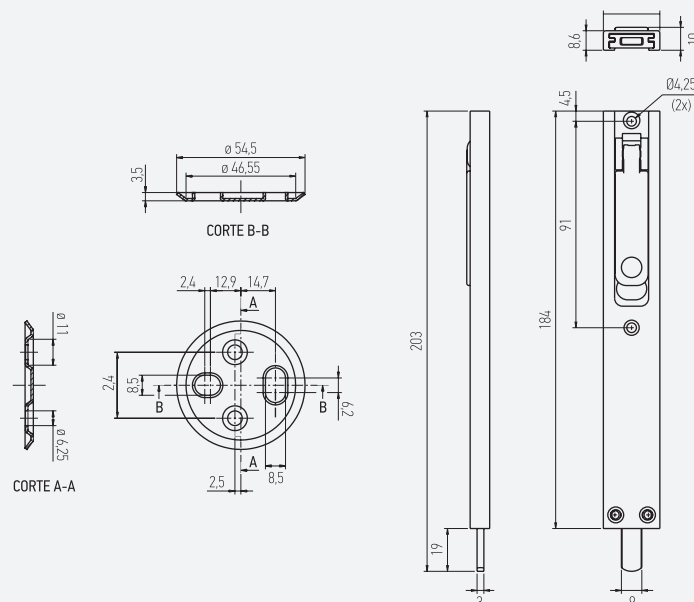



FECHO PARA C. EUROPEIA
LOCK FOR E.G. SERIES
CIERRE PARA C. EUROPEO
VERROUS POUR C. EUROPÉENNE

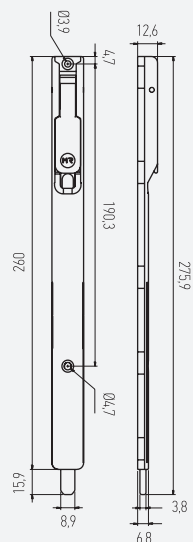
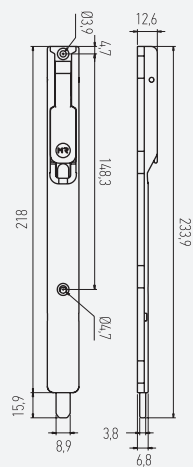
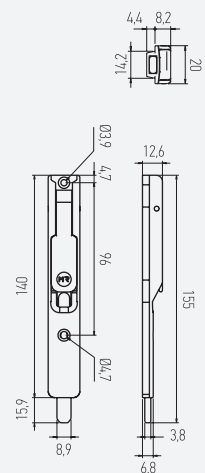

EMBALAGEM - PACKAGING
EMPAQUETADO - EMBALLAGE

24 unidades por caixa
24 pieces per box
24 unidades por caja
24 pieces par boîte

FIXAÇÃO - FIXING
FIJACIÓN - FIXATION

Parafusos incluídos
Screws included
Tornillos incluidos
Vis inclus

MATERIAIS - MATERIALS
MATERIALES - MATERIAUX

Alumínio - Zamak - Inox
Aluminium - Zamak - Stainless steel
Aluminio - Zamak - Acero inox
Aluminium - Zamak - Inox

ACABAMENTO - FINISHING
ACABADOS - FINITION

Lacado
Powder painting
Lacado
Laqué

NORMA - STANDARD
NORMA - NORME

EN 1670



FECHO CE
2.ª FOLHA PONT. 503



KIT CE
PONT. 503



FECHO CE
2.ª FOLHA PONT. 510



KIT CE
PONT. 510

EMBALAGEM - PACKAGING
EMPAQUETADO - EMBALLAGE

50 unidades por caixa
50 pieces per box
50 unidades por caja
50 pieces par boîte

MATERIAIS - MATERIALS
MATERIALES - MATERIAUX

Nylon - Zamak - Inox
Nylon - Zamak - Stainless steel
Nylon - Zamak - Acero inox
Nylon - Zamak - Inox

FIXAÇÃO - FIXING
FIJACIÓN - FIXATION

Parafusos incluídos
Screws included
Tornillos incluidos
Vis inclus

NORMA - STANDARD
NORMA - NORME

EN 1670

OBSERVAÇÕES - COMENTS
OBSERVACIONES - OBSERVATIONS

Fecho A-0-40 (18mm)
Fecho A7 Pont. 503
Fecho A7 Pont. 510:
50 unidades por caixa
50 unidades por caja
50 pieces par boîte

Kit CE Canal 10/14:
50 unidades por caixa
50 unidades por caja
50 pieces par boîte

KITS E FECHOS PARA C. EUROPEIA · KITS AND LOCKS FOR E.G. SERIES · KITS Y CIERRES PARA C. EUROPEO · KITS ET VERROUS POUR C. EUROPÉENNE

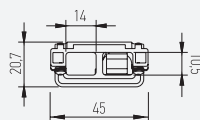
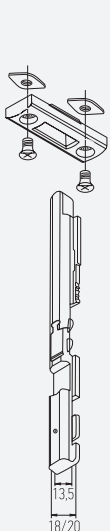

Canal 10/14

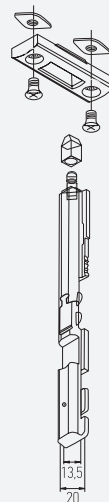



FECHO 2.ª FOLHA
126/124
136/134



KIT A1 BP 927
(CANAL 22)
(CANAL 28)

EMBALAGEM - PACKAGING
EMPAQUETADO - EMBALLAGE

FECHO 2.ª FOLHA
126/124

136/134:
24 unidades por caixa
24 pieces per box
24 unidades por caja
24 pieces par boîte

KIT A1 BP 927
(CANAL 22)

(CANAL 28):
50 unidades por caixa
50 pieces per box
50 unidades por caja
50 pieces par boîte

MATERIAIS - MATERIALS
MATERIALES - MATERIAUX

Zamak - Nylon
Zamak - Nylon
Zamak - Nylon
Zamak - Nylon

FIXAÇÃO - FIXING
FIJACIÓN - FIXATION

Parafusos incluídos
Screws included
Tornillos incluidos
Vis inclus

ACABAMENTO - FINISHING
ACABADOS - FINITION

Zincado
Zinc plated
Zincado
Zingué

NORMA - STANDARD
NORMA - NORME

EN 1670

KITS E FECHOS PARA SÉRIES DE 40 · KITS AND LOCKS FOR SERIES OF 40 · KITS Y CIERRES PARA SÉRIES DE 40 · KITS ET VERROUS POUR SÉRIES DE 40

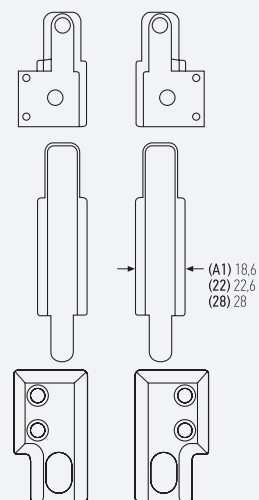
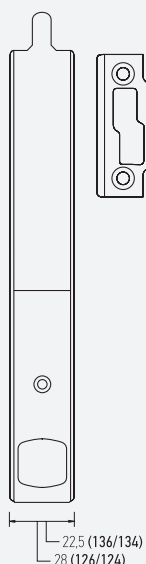



**KIT FECHO
5000/ EKIP-40**



**KIT CREMONE
5000/ EKIP-40**

**EMBALAGEM - PACKAGING
EMPAQUETADO - EMBALLAGE**

50 unidades por caixa
50 pieces per box
50 unidades por caja
50 pieces par boîte

**MATERIAIS - MATERIALS
MATERIALES - MATERIAUX**

Nylon - Zamak - Inox
Nylon - Zamak - Stainless steel
Nylon - Zamak - Acero inox
Nylon - Zamak - Inox

**FIXAÇÃO - FIXING
FIJACIÓN - FIXATION**

Parafusos incluídos
Screws included
Tornillos incluidos
Vis inclus

**NORMA - STANDARD
NORMA - NORME**

EN 1670

KIT EKIP-40

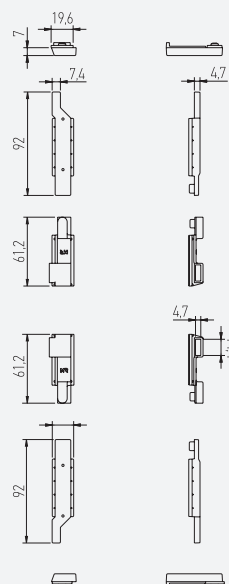
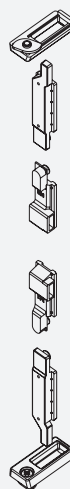
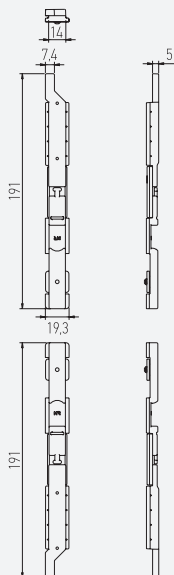



KIT 6200



**EXTENSOR PARA PATILHA
DE CREMONE**



ref. ^a	Tam. (A)
49088	11 mm
49089	16 mm
49090	23 mm

**EMBALAGEM - PACKAGING
EMPAQUETADO - EMBALLAGE**

12 unidades por caixa
12 pieces per box
12 unidades por caja
12 pieces par boîte

**MATERIAIS - MATERIALS
MATERIALES - MATERIAUX**

Alumínio - Zamak - Nylon
Aluminium - Zamak - Nylon
Aluminio - Zamak - Nylon
Aluminium - Zamak - Nylon

**FIXAÇÃO - FIXING
FIJACIÓN - FIXATION**

Parafusos incluídos
Screws included
Tornillos incluidos
Vis inclus

**ACABAMENTO - FINISHING
ACABADOS - FINITION**

Zincado
Zinc plated
Zincado
Zingué

**NORMA - STANDARD
NORMA - NORME**

EN 1670

**OBSERVAÇÕES - COMENTS
OBSERVACIONES - OBSERVATIONS**

Extensor:
50 pares por caixa
50 pairs per box
50 pares por caja
50 paires par boîte

KITS E FECHOS PARA SÉRIES DE 40 · KITS ANO LOCKS FOR SERIES OF 40 · KITS Y CIERRES PARA SÉRIES DE 40 · KITS ET VERROUS POUR SÉRIES DE 40

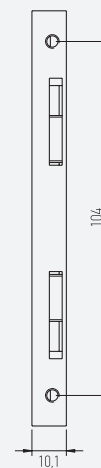
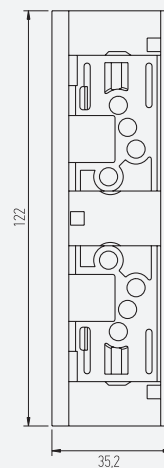
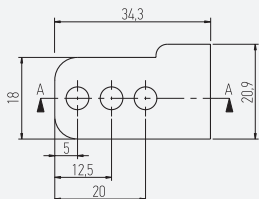
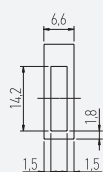

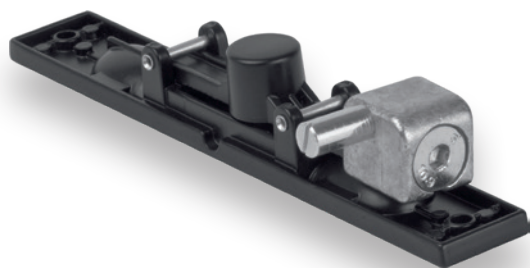

205/567



205



**EMBALAGEM - PACKAGING
EMPAQUETADO - EMBALLAGE**

25 unidades por caixa
25 pieces per box
25 unidades por caja
25 pieces par boîte

**MATERIAIS - MATERIALS
MATERIALES - MATERIAUX**

Alumínio - Zamak
Aluminium - Zamak
Aluminio - Zamak
Aluminium - Zamak

**ACABAMENTO - FINISHING
ACABADOS - FINITION**

Lacado
Powder painting
Lacado
Laqué

**NORMA - STANDARD
NORMA - NORME**

EN 1670

FECHO DE UNHA · BARREL BOLT · CIERRE DE UNA · VERROU DE PORTE

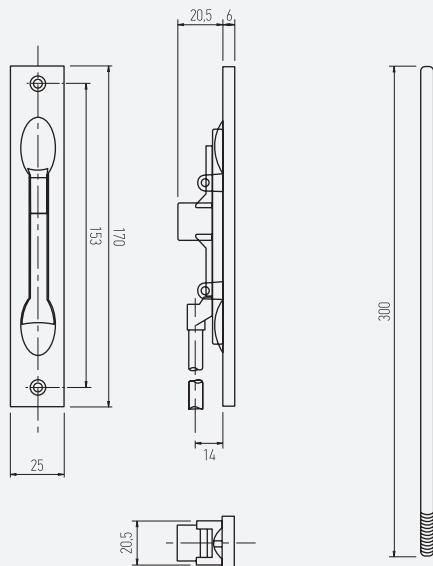



ASSA ABLOY



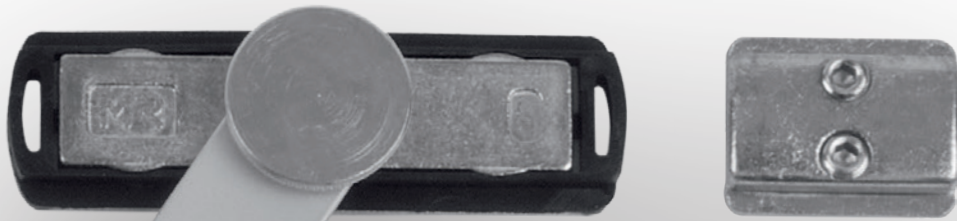

COMPASSOS E FECHOS

STAYS AND ITS LOCKING

COMPASES Y CIERRES

COMPAS ET VERROUILLAGE



MR 02

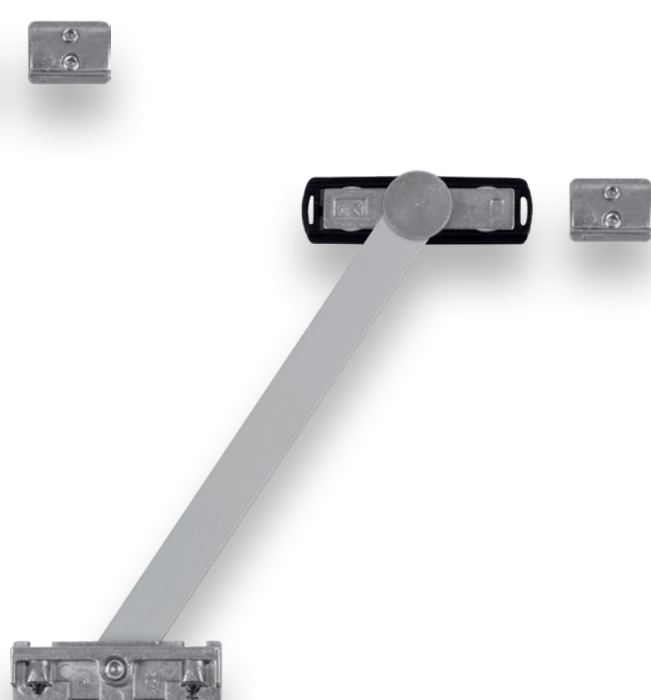

MR 01

**EMBALAGEM - PACKAGING
EMPAQUETADO - EMBALLAGE**

50 unidades por caixa
50 pieces per box
50 unidades por caja
50 pieces par boîte

**MATERIAIS - MATERIALS
MATERIALES - MATERIAUX**

Alumínio - Zamak - Nylon
Aluminium - Zamak - Nylon
Aluminio - Zamak - Nylon
Aluminium - Zamak - Nylon

**FIXAÇÃO - FIXING
FIJACIÓN - FIXATION**

Parafusos incluídos
Screws included
Tornillos incluidos
Vis inclus

**ACABAMENTO - FINISHING
ACABADOS - FINITION**

Anodizado / Zincado
Anodized / Zinc plated
Anodizado / Zincado
Anodisé / Zingué

**NORMA - STANDARD
NORMA - NORME**

EN 1670
EN 13126

COMPASSO PARA C. EUROPEIA · COMPASS FOR E.G. SERIES · COMPÁS PARA C. EUROPEO · COMPAS POUR C. EUROPÉENNE

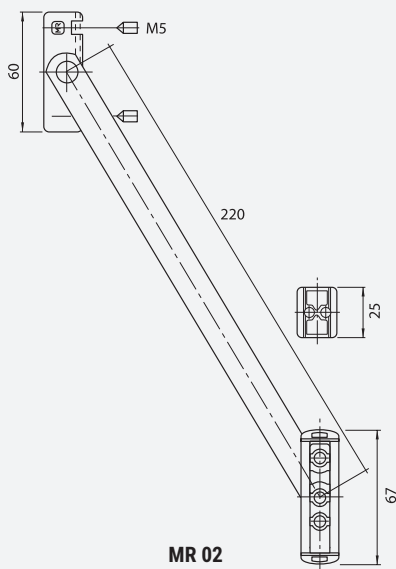

MR 02

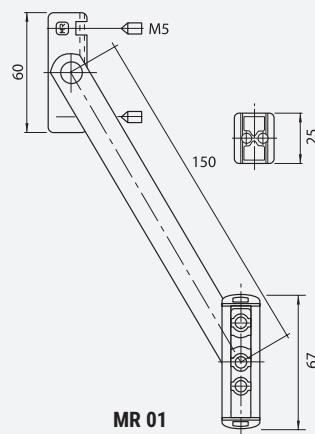

MR 01

FECHO JANELAS BASCULANTES
LOCK FOR SWINGING WINDOWS
CIERRE VENTANAS ABATIBLES
LOQUETEAUX FENÊTRES ABATTABLES

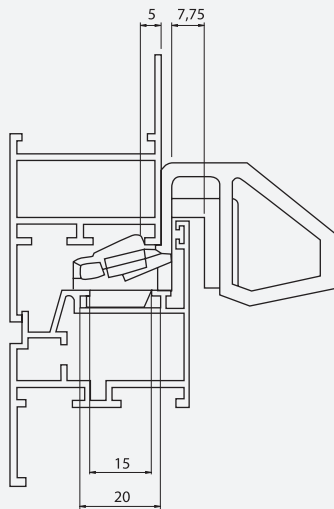
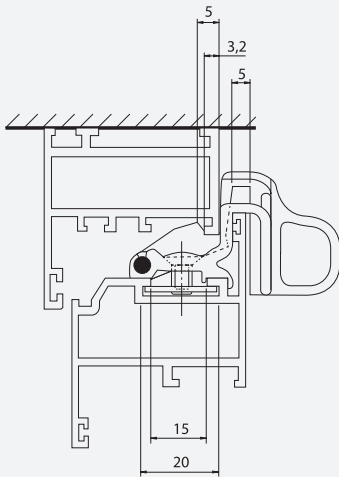

Regulável
adjustable
regulable
réglable

4606



9000

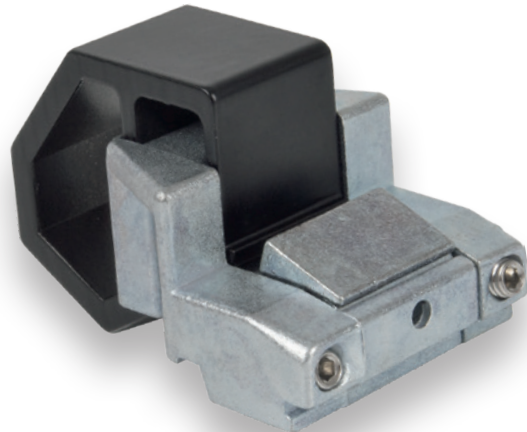

EMBALAGEM - PACKAGING
EMPAQUETADO - EMBALLAGE

50 unidades por caixa
50 pieces per box
50 unidades por caja
50 pieces par boîte

MATERIAIS - MATERIALS
MATERIALES - MATERIAUX

Alumínio - Zamak - Nylon
Aluminium - Zamak - Nylon
Aluminio - Zamak - Nylon
Aluminium - Zamak - Nylon

FIXAÇÃO - FIXING
FIJACIÓN - FIXATION

Parafusos incluídos
Screws included
Tornillos incluidos
Vis inclus

ACABAMENTO - FINISHING
ACABADOS - FINITION

Lacado
Powder painting
Lacado
Laqué

NORMA - STANDARD
NORMA - NORME

EN 1670
EN 13126

606
606.ES

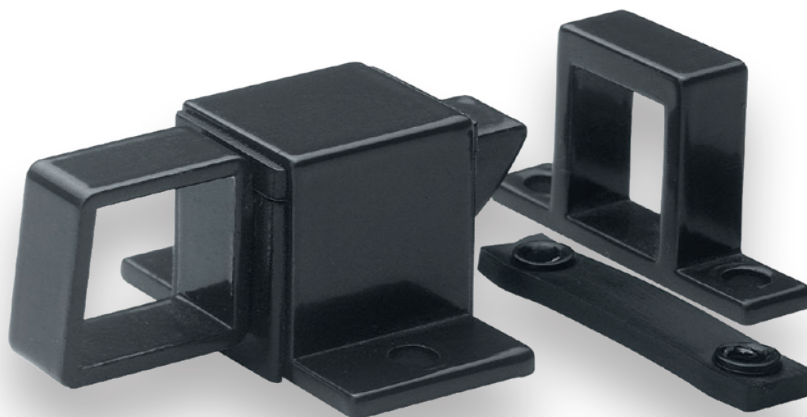

EMBALAGEM - PACKAGING
EMPAQUETADO - EMBALLAGE

100 unidades por caixa
100 pieces per box
100 unidades por caja
100 pieces par boîte

MATERIAIS - MATERIALS
MATERIALES - MATERIAUX

Alumínio - Nylon
Aluminium - Nylon
Aluminio - Nylon
Aluminium - Nylon

ACABAMENTO - FINISHING
ACABADOS - FINITION

Lacado / Anodizado
Powder painting / Anodized
Lacado / Anodizado
Laqué / Anodisé

NORMA - STANDARD
NORMA - NORME

EN 1670
EN 13126

OBSERVAÇÕES - COMMENTS
OBSERVACIONES - OBSERVATIONS

170
Nylon branco/preto **50 unidades por caixa**
Nylon white/black 50 pieces per box
Nylon blanco/negro 50 unidades por caja
Nylon blanc/noir 50 pieces par boîte

FECHO BANDEIRA · LOCK FOR SWINGING WINDOWS · CIERRE VENTANAS ABATIBLES · LOQUETEAUX FENÊTRES ABATTABLES

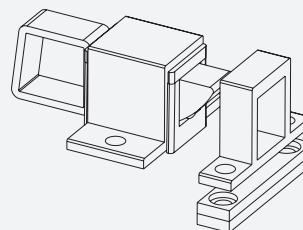
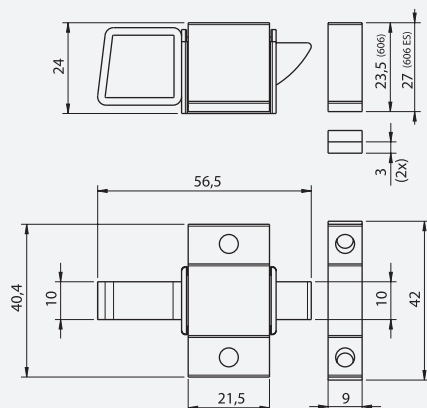
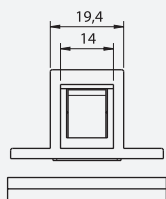

COMPASSO PROJECTANTE INOX 304

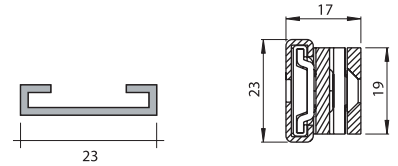

REF.	Medida do Compasso (mm)	Peso máximo da folha (kg)	Medida da folha min / máx. (mm)	Ângulo de abertura
23/263	262,9	50	280 / 762	75°
23/415	414,9	63	457 / 1120	87°
23/567	566,9	75	610 / 1321	90°

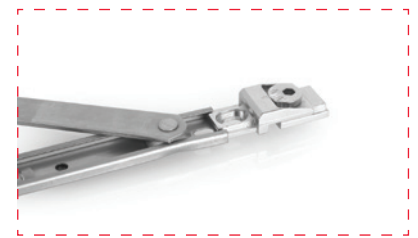
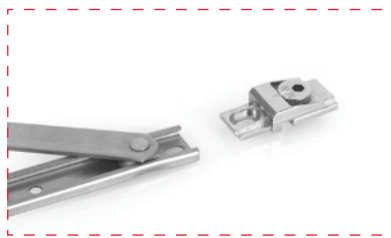

AP23 - Regulador de fixação

**EMBALAGEM - PACKAGING
EMPAQUETADO - EMBALLAGE**

6 pares por caixa
6 pairs per box
6 pares por caja
6 paires par boîte

**MATERIAIS - MATERIALS
MATERIALES - MATERIAUX**

Inox (304) - Zamak
Stainless steel (304) - Zamak
Acero inox (304) - Zamak
Inox (304) - Zamak

**FIXAÇÃO - FIXING
FIJACIÓN - FIXATION**

Parafusos incluídos
Screws included
Tornillos incluidos
Vis inclus

**NORMA - STANDARD
NORMA - NORME**

EN 1670
EN 13126

**OBSERVAÇÕES - COMMENTS
OBSERVACIONES - OBSERVATIONS**

AP23
24 unidades por caixa
24 pieces per box
24 unidades por caja
24 piezas par boîte

Esq. Reenvio
50 unidades por caixa
50 pieces per box
50 unidades por caja
50 piezas par boîte

33532 / 33533
50 unidades por caixa
50 pieces per box
50 unidades por caja
50 piezas par boîte

COMPASSO PROJECTANTE · PROJECTING COMPASS · COMPÁS PROYECTANTE · COMPAS DE PROJECTION

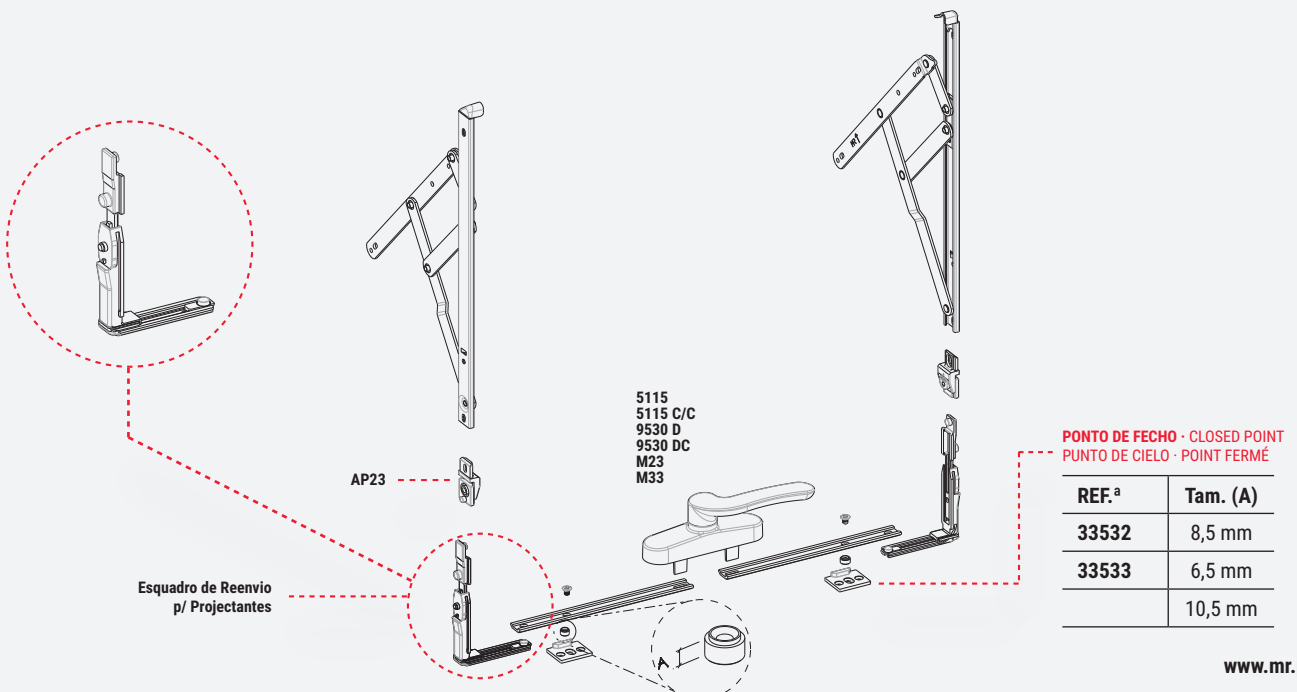

**PONTO DE FECHO · CLOSED POINT
PUNTO DE CIELO · POINT FERMÉ**

REF. ^a	Tam. (A)
33532	8,5 mm
33533	6,5 mm
	10,5 mm

Esquadro de Reenvio
p/ Projectantes



ASSA ABLOY





DOBRADIÇAS

HINGES

BISAGRAS

PAUMELLES



5040



9110

EMBALAGEM - PACKAGING
EMPAQUETADO - EMBALLAGE

12 unidades por caixa
12 pieces per box
12 unidades por caja
12 pieces par boîte

MATERIAIS - MATERIALS
MATERIALES - MATERIAUX

Alumínio - Nylon
Alluminium - Nylon
Aluminio - Nylon
Alluminium - Nylon

FIXAÇÃO - FIXING
FIJACIÓN - FIXATION

Parafusos incluídos
Screws included
Tornillos incluidos
Vis inclus

ACABAMENTO - FINISHING
ACABADOS - FINITION

Lacado / Anodizado
Powder painting / Anodized
Lacado / Anodizado
Laqué / Anodisé

NORMA - STANDARD
NORMA - NORME

EN 1670
EN 1935

DOBRADIÇAS · HINGES · BISAGRAS · PAUMELLES

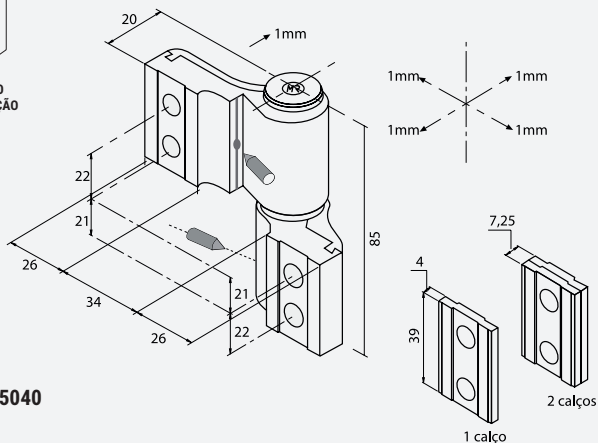
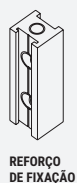

5040

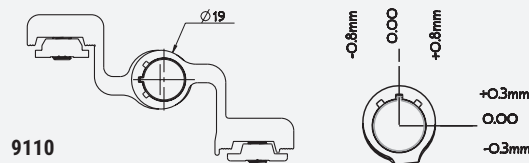
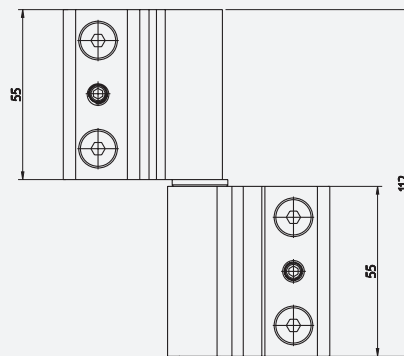

9110



9100



9101.3D

EMBALAGEM - PACKAGING
EMPAQUETADO - EMBALLAGE

12 unidades por caixa
12 pieces per box
12 unidades por caja
12 pieces par boîte

MATERIAIS - MATERIALS
MATERIALES - MATERIAUX

Alumínio - Nylon
Alluminium - Nylon
Aluminio - Nylon
Alluminium - Nylon

FIXAÇÃO - FIXING
FIJACIÓN - FIXATION

Parafusos incluídos
Screws included
Tornillos incluidos
Vis inclus

ACABAMENTO - FINISHING
ACABADOS - FINITION

Lacado / Anodizado
Powder painting / Anodized
Lacado / Anodizado
Laqué / Anodisé

NORMA - STANDARD
NORMA - NORME

EN 1670
EN 1935

OBSERVAÇÕES - COMENTS
OBSERVACIONES - OBSERVATIONS

9100:
Afinação só lateral
Side only adjustment
Afinación lateral
Réglage latéral seulement

DOBRADIÇAS · HINGES · BISAGRAS · PAUMELLES

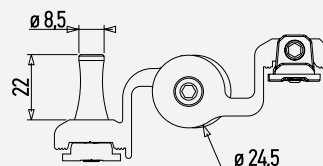
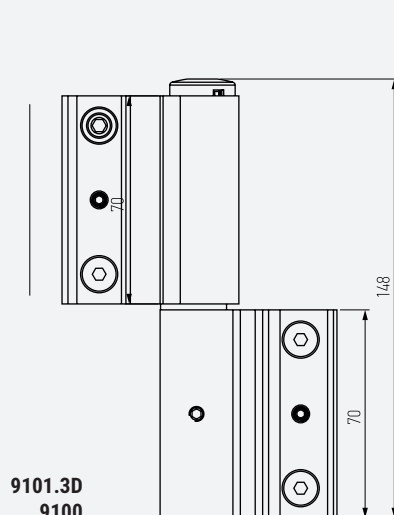

9101.3D

5060 3F (Cunha zamak)
5080 3F (Cunha inox)



DOBRADIÇA PARA C. EUROPEIA
HINGES FOR E.G. SERIES
BISAGRAS PARA C. EUROPEO
PAUMELLES POUR C. EUROPÉENNE

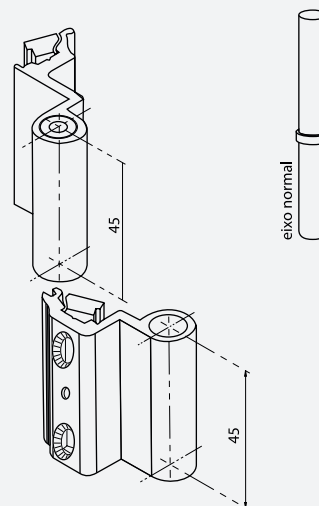

5060 3F / 5080 3F

5060 (Cunha zamak)
5080 (Cunha inox)

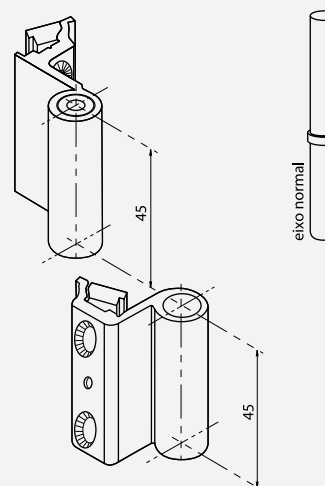

5060 / 5080

EMBALAGEM - PACKAGING
EMPAQUETADO - EMBALLAGE

50 unidades por caixa
50 pieces per box
50 unidades por caja
50 pieces par boîte

MATERIAIS - MATERIALS
MATERIALES - MATERIAUX

Alumínio - Zamak - Inox
Alluminium - Zamak - Stainless Steel
Aluminio - Zamak - Acero Inox
Alluminium - Zamak - Inox

FIXAÇÃO - FIXING
FIJACIÓN - FIXATION

Parafusos incluídos
Screws included
Tornillos incluidos
Vis inclus

ACABAMENTO - FINISHING
ACABADOS - FINITION

Lacado / Anodizado
Powder painting / Anodized
Lacado / Anodizado
Laqué / Anodisé

NORMA - STANDARD
NORMA - NORME

EN 1670
EN 1935

DOBRADIÇA PARA C. EUROPEIA
HINGES FOR E.G. SERIES
BISAGRAS PARA C. EUROPEO
PAUMELLES POUR C. EUROPÉENNE

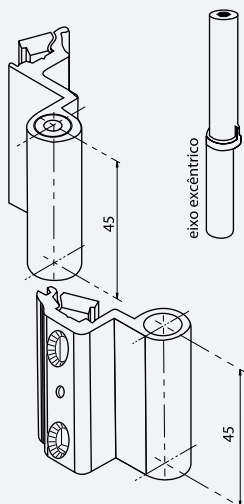

5050 3F
5070 3F

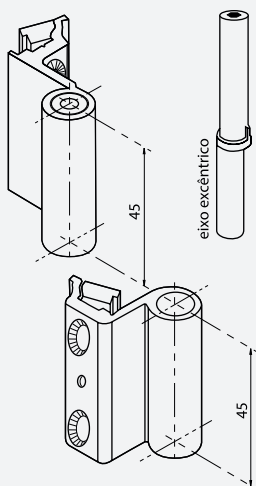

5050
5070

5050 3F (Cunha zamak)
5070 3F (Cunha inox)



5050 (Cunha zamak)
5070 (Cunha inox)



EMBALAGEM - PACKAGING
EMPAQUETADO - EMBALLAGE

50 unidades por caixa
50 pieces per box
50 unidades por caja
50 pieces par boîte

MATERIAIS - MATERIALS
MATERIALES - MATERIAUX

Alumínio - Zamak - Inox
Alluminium - Zamak - Stainless Steel
Aluminio - Zamak - Acero Inox
Alluminium - Zamak - Inox

FIXAÇÃO - FIXING
FIJACIÓN - FIXATION

Parafusos incluídos
Screws included
Tornillos incluidos
Vis inclus

ACABAMENTO - FINISHING
ACABADOS - FINITION

Lacado / Anodizado
Powder painting / Anodized
Lacado / Anodizado
Laqué / Anodisé

NORMA - STANDARD
NORMA - NORME

EN 1670
EN 1935



5060 TRIPLA
5060 TRIPLA 3F



5060 BALANÇO

EMBALAGEM - PACKAGING
EMPAQUETADO - EMBALLAGE

25 unidades por caixa
25 pieces per box
25 unidades por caixa
25 pieces par boîte

MATERIAIS - MATERIALS
MATERIALES - MATERIAUX

Alumínio - Zamak - Inox
Alluminium - Zamak - Stainless Steel
Aluminio - Zamak - Acero Inox
Alluminium - Zamak - Inox

FIXAÇÃO - FIXING
FIJACIÓN - FIXATION

Parafusos incluídos
Screws included
Tornillos incluidos
Vis inclus

ACABAMENTO - FINISHING
ACABADOS - FINITION

Lacado / Anodizado
Powder painting / Anodized
Lacado / Anodizado
Laqué / Anodisé

NORMA - STANDARD
NORMA - NORME

EN 1670
EN 1935

OBSERVAÇÕES - COMENTS
OBSERVACIONES - OBSERVATIONS

5060 BALANÇO:
20 unidades por caixa
20 pieces per box
20 unidades por caixa
20 pieces par boîte

DOBRADIÇA PARA C. EUROPEIA · HINGES FOR E.G. SERIES · BISAGRAS PARA C. EUROPEO · PAUMELLES POUR C. EUROPÉENNE

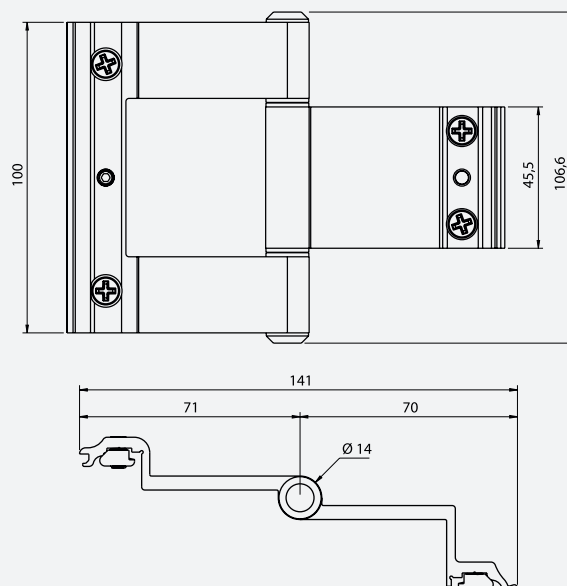
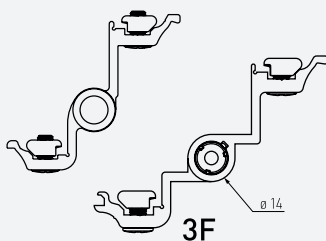
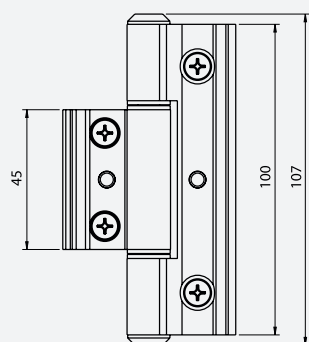

5085

DOBRADIÇA
HINGES
BISAGRAS
PAUMELLES

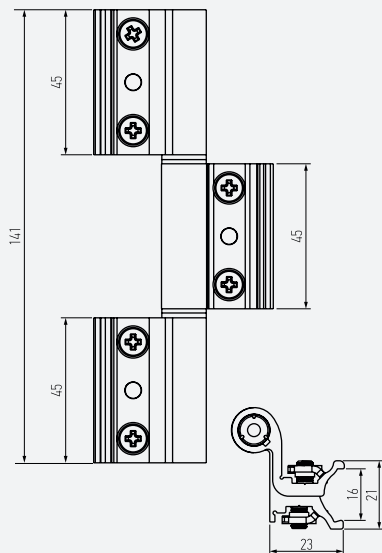

EMBALAGEM - PACKAGING
EMPAQUETADO - EMBALLAGE

25 unidades por caixa
25 pieces per box
25 unidades por caja
25 pieces par boîte

MATERIAIS - MATERIALS
MATERIALES - MATERIAUX

Alumínio - Zamak - Inox
Alluminium - Zamak - Stainless Steel
Aluminio - Zamak - Acero Inox
Alluminium - Zamak - Inox

FIXAÇÃO - FIXING
FIJACIÓN - FIXATION

Parafusos incluídos
Screws included
Tornillos incluidos
Vis inclus

ACABAMENTO - FINISHING
ACABADOS - FINITION

Lacado
Powder painting
Lacado
Laqué

NORMA - STANDARD
NORMA - NORME

EN 1670
EN 1935

5031



5031 TRIPLA

DOBRADIÇA REVERSÍVEL P/ SÉRIES DE 40
REVERSIBLE HINGE FOR 40 SERIES
BISAGRA REVERSIBLE PARA SERIES DE 40
CHARNIÈRE REVERSIBLE POUR SERIES DE 40

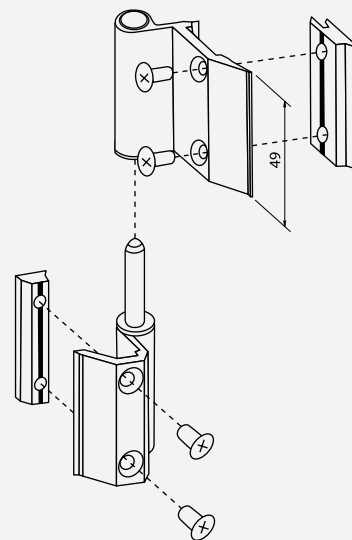

5031

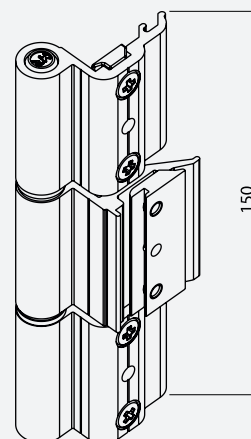

EMBALAGEM - PACKAGING
EMPAQUETADO - EMBALLAGE

50 unidades por caixa
50 pieces per box
50 unidades por caja
50 pieces par boîte

MATERIAIS - MATERIALS
MATERIALES - MATERIAUX

Alumínio - Zamak - Inox
Alluminium - Zamak - Stainless Steel
Aluminio - Zamak - Acero Inox
Alluminium - Zamak - Inox

FIXAÇÃO - FIXING
FIJACIÓN - FIXATION

Parafusos incluídos
Screws included
Tornillos incluidos
Vis inclus

ACABAMENTO - FINISHING
ACABADOS - FINITION

Lacado / Anodizado
Powder painting / Anodized
Lacado / Anodizado
Laqué / Anodisé

NORMA - STANDARD
NORMA - NORME

EN 1670
EN 1935

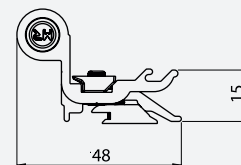

5031 TRIPLA



6000 / A6



6000 / A6 3F

**EMBALAGEM - PACKAGING
EMPAQUETADO - EMBALLAGE**

50 unidades por caixa
50 pieces per box
50 unidades por caja
50 pieces par boîte

**MATERIAIS - MATERIALS
MATERIALES - MATERIAUX**

Alumínio - Zamak - Inox
Alluminium - Zamak - Stainless Steel
Aluminio - Zamak - Acero Inox
Alluminium - Zamak - Inox

**FIXAÇÃO - FIXING
FIJACIÓN - FIXATION**

Parafusos incluídos
Screws included
Tornillos incluidos
Vis inclus

**ACABAMENTO - FINISHING
ACABADOS - FINITION**

Lacado / Anodizado
Powder painting / Anodized
Lacado / Anodizado
Laqué / Anodisé

**NORMA - STANDARD
NORMA - NORME**

EN 1670
EN 1935

DOBRADIÇA REVERSÍVEL P/ SÉRIES DE 40 · REVERSIBLE HINGE FOR 40 SERIES · BISAGRA REVERSIBLE PARA SERIES DE 40 · CHARNIÈRE REVERSIBLE POUR SERIES DE 40

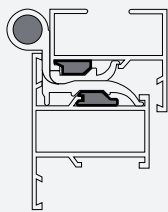

Abertura para exterior

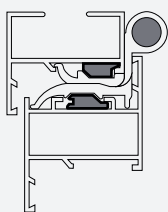

Abertura para interior

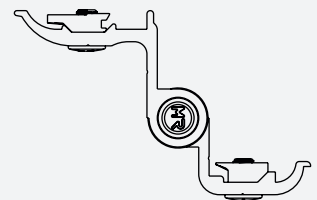
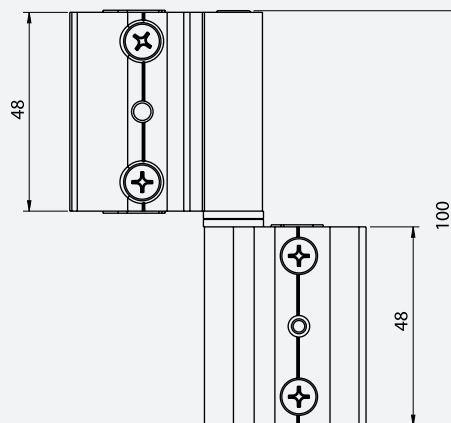



A7 BALANÇO



**A7 TRIPLA
A7 TRIPLA C/ AVANÇO**

**EMBALAGEM - PACKAGING
EMPAQUETADO - EMBALLAGE**

25 unidades por caixa
25 pieces per box
25 unidades por caja
25 pieces par boîte

**MATERIAIS - MATERIALS
MATERIALES - MATERIAUX**

Alumínio - Zamak - Inox
Alluminium - Zamak - Stainless Steel
Aluminio - Zamak - Acero Inox
Alluminium - Zamak - Inox

**FIXAÇÃO - FIXING
FIJACIÓN - FIXATION**

Parafusos incluídos
Screws included
Tornillos incluidos
Vis inclus

**ACABAMENTO - FINISHING
ACABADOS - FINITION**

Lacado / Anodizado
Powder painting / Anodized
Lacado / Anodizado
Laqué / Anodisé

**NORMA - STANDARD
NORMA - NORME**

EN 1670
EN 1935

**OBSERVAÇÕES - COMENTS
OBSERVACIONES - OBSERVATIONS**

A7 BALANÇO:
20 unidades por caixa
20 pieces per box
20 unidades por caja
20 pieces par boîte

DOBRADIÇAS · HINGES · BISAGRAS · PAUMELLES

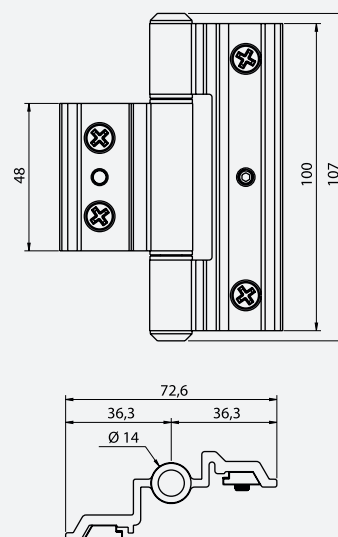
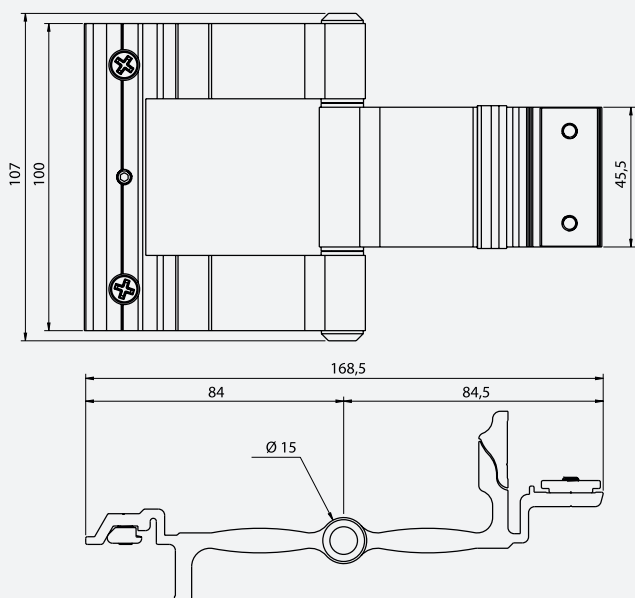



A7.29



**A7
C/ AVANÇO**

**EMBALAGEM - PACKAGING
EMPAQUETADO - EMBALLAGE**

50 unidades por caixa
50 pieces per box
50 unidades por caja
50 pieces par boîte

**MATERIAIS - MATERIALS
MATERIALES - MATERIAUX**

Alumínio - Zamak - Inox
Alluminium - Zamak - Stainless Steel
Aluminio - Zamak - Acero Inox
Alluminium - Zamak - Inox

**FIXAÇÃO - FIXING
FIJACIÓN - FIXATION**

Parafusos incluídos
Screws included
Tornillos incluidos
Vis inclus

**ACABAMENTO - FINISHING
ACABADOS - FINITION**

Lacado / Anodizado
Powder painting / Anodized
Lacado / Anodizado
Laqué / Anodisé

**NORMA - STANDARD
NORMA - NORME**

EN 1670
EN 1935

DOBRADIÇAS · HINGES · BISAGRAS · PAUMELLES

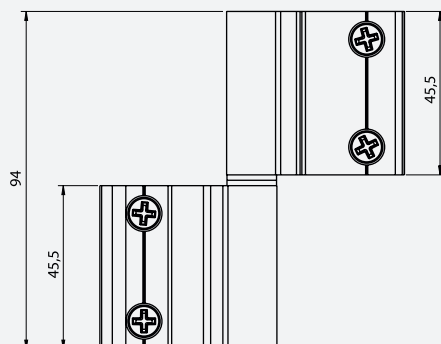

A7.29

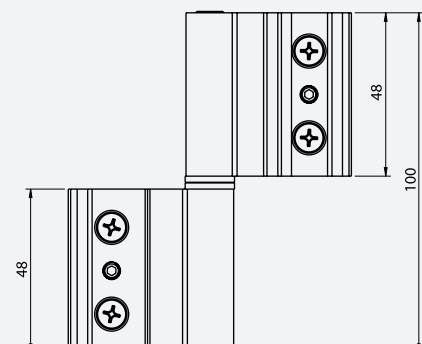

A7

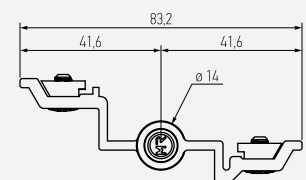

A7 C/ AVANÇO

**HP BALANÇO
4250/4187**



HP 3F



**HP BALANÇO
4250/4188**



HP

**EMBALAGEM - PACKAGING
EMPAQUETADO - EMBALLAGE**

50 unidades por caixa
50 pieces per box
50 unidades por caja
50 pieces par boîte

**MATERIAIS - MATERIALS
MATERIALES - MATERIAUX**

Alumínio - Zamak - Inox
Alluminium - Zamak - Stainless Steel
Aluminio - Zamak - Acero Inox
Alluminium - Zamak - Inox

**FIXAÇÃO - FIXING
FIJACIÓN - FIXATION**

Parafusos incluídos
Screws included
Tornillos incluidos
Vis inclus

**ACABAMENTO - FINISHING
ACABADOS - FINITION**

Lacado / Anodizado
Powder painting / Anodized
Lacado / Anodizado
Laqué / Anodisé

**NORMA - STANDARD
NORMA - NORME**

EN 1670
EN 1935

**OBSERVAÇÕES - COMENTS
OBSERVACIONES - OBSERVATIONS**

HP BALANÇO:
25 unidades por caixa
25 pieces per box
25 unidades por caja
25 pieces par boîte

DOBRADIÇAS · HINGES · BISAGRAS · PAUMELLES

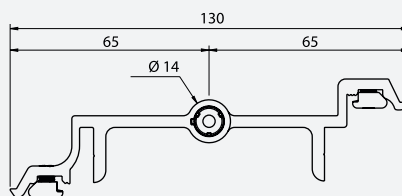
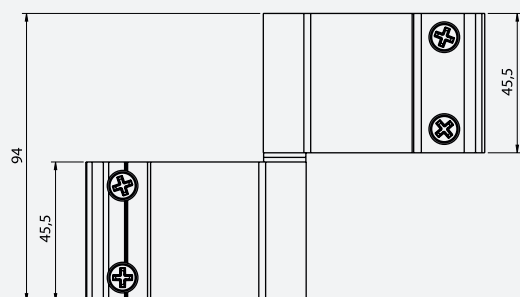

**HP BALANÇO
4250/4187**

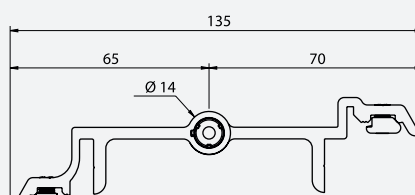
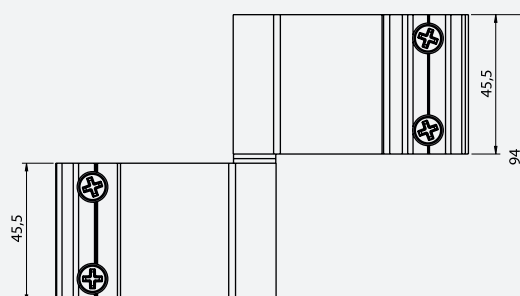
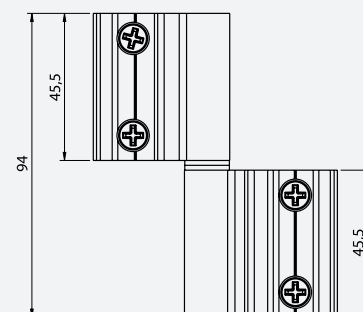

**HP BALANÇO
4250/4188**

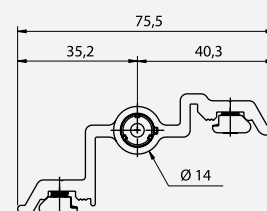

DOBRADIÇAS
HINGES
BISAGRAS
PAUMELLES

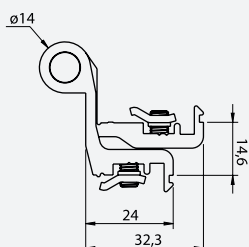
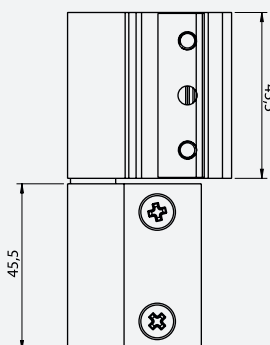
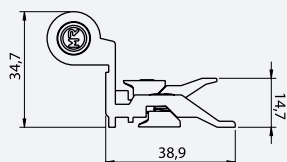
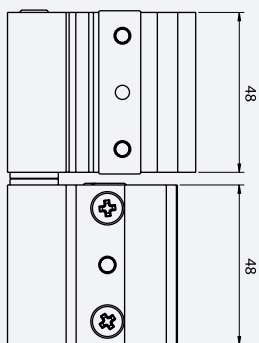

AL 7
MT/SN



EKIP-40



EMBALAGEM - PACKAGING
EMPAQUETADO - EMBALLAGE

50 unidades por caixa
50 pieces per box
50 unidades por caja
50 pieces par boîte

MATERIAIS - MATERIALS
MATERIALES - MATERIAUX

Alumínio - Zamak - Inox
Alluminium - Zamak - Stainless Steel
Aluminio - Zamak - Acero Inox
Alluminium - Zamak - Inox

FIXAÇÃO - FIXING
FIJACIÓN - FIXATION

Parafusos incluídos
Screws included
Tornillos incluidos
Vis inclus

ACABAMENTO - FINISHING
ACABADOS - FINITION

Lacado / Anodizado
Powder painting / Anodized
Lacado / Anodizado
Laqué / Anodisé

NORMA - STANDARD
NORMA - NORME

EN 1670
EN 1935

2004

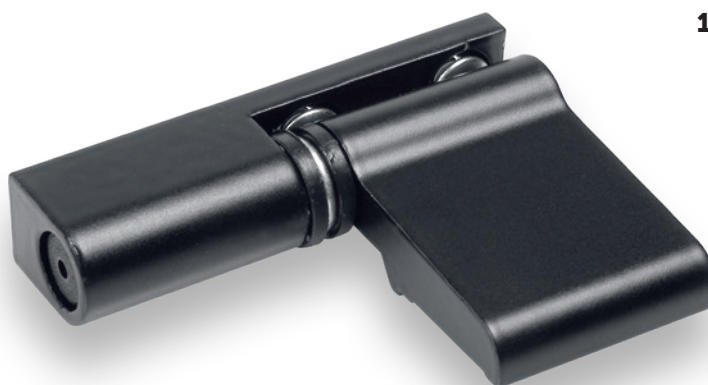
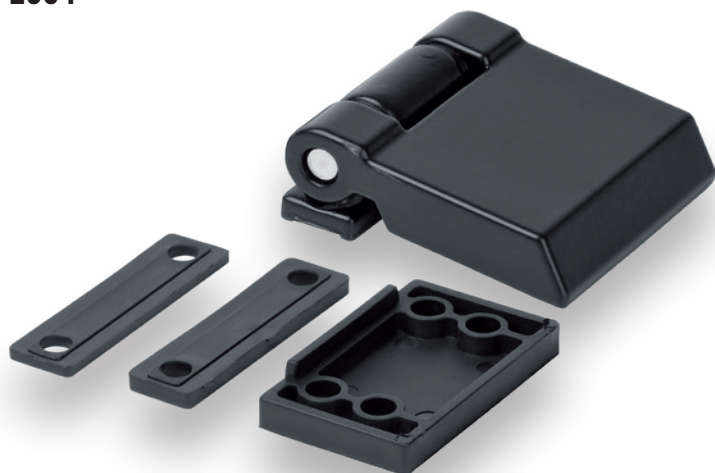

1000

EMBALAGEM - PACKAGING
EMPAQUETADO - EMBALLAGE

50 unidades por caixa
50 pieces per box
50 unidades por caja
50 pieces par boîte

MATERIAIS - MATERIALS
MATERIALES - MATERIAUX

Alumínio - Zamak - Inox
Alluminium - Zamak - Stainless Steel
Aluminio - Zamak - Acero Inox
Alluminium - Zamak - Inox

FIXAÇÃO - FIXING
FIJACIÓN - FIXATION

Parafusos incluídos
Screws included
Tornillos incluidos
Vis inclus

ACABAMENTO - FINISHING
ACABADOS - FINITION

Lacado
Powder painting
Lacado
Laqué

NORMA - STANDARD
NORMA - NORME

EN 1670
EN 1935

DOBRADIÇAS · HINGES · BISAGRAS · PAUMELLES

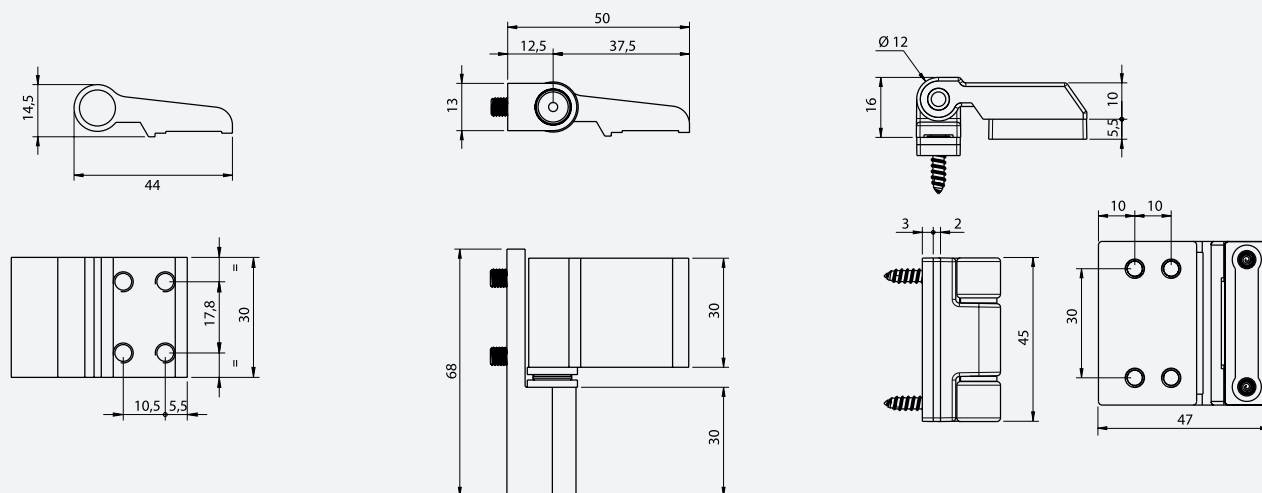

DOBRADIÇAS
HINGES
BISAGRAS
PAUMELLES

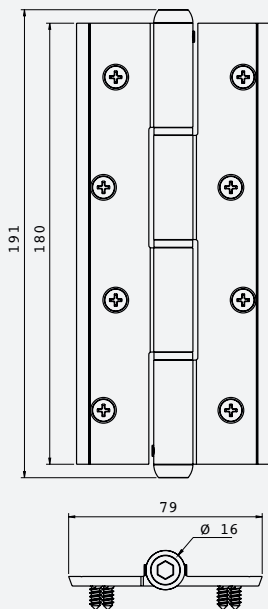
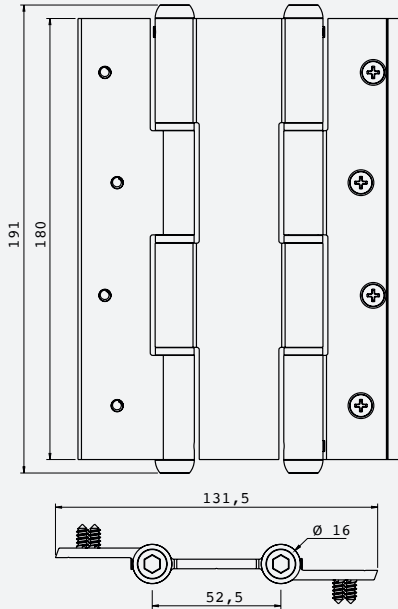

**DOBRADIÇA
DE VAI-VEM**



**DOBRADIÇA
DE MOLA**

MATERIAIS - MATERIALS
MATERIALES - MATERIAUX

Alumínio
Alluminium
Aluminio
Alluminium

FIXAÇÃO - FIXING
FIJACIÓN - FIXATION

Parafusos incluídos
Screws included
Tornillos incluidos
Vis inclus

ACABAMENTO - FINISHING
ACABADOS - FINITION

Lacado / Anodizado
Powder painting / Anodized
Lacado / Anodizado
Laqué / Anodisé

NORMA - STANDARD
NORMA - NORME

EN 1670
EN 1935

OBSERVAÇÕES - COMENTS
OBSERVACIONES - OBSERVATIONS

DOBRADIÇA DE VAI-VEM:
2 unidades por caixa
2 pieces per box
2 unidades por caja
2 pieces par boîte

DOBRADIÇA DE MOLA:
4 unidades por caixa
4 pieces per box
4 unidades por caja
4 pieces par boîte



ASSA ABLOY





SISTEMA ELEVÁVEL

LIFT & SLIDE

CORREDERA ELEVABLE

COULISSANT ELEVABLE

- 1 Pux 4330U
- 2 Pux 4330 c/c
- 3 Kit carros 200/300
- 4 Carros int. 200/300
- 5 Carros correr 300 (150 kg)
- 6 7 8 9 Corpo fechadura
- 10 Prolongador f. c/ fecho
- 11 Prolongador fech.
- 12 13 14 15 Varetas ligação
- 16 Kit suplementos
- 17 Ponto fecho zamak
- 18 Batente nylon
- 19 Topo batente
- 20 Peça ventilação
- 21 Mola
- 22 Calço ponto fecho zamak
- 23 Guia nylon varetas ligação
- 24 Kit folha fixa zamak
- 25 Contraplaca p/ ponto fecho
- 26 Carro correr 300 (110 kg)

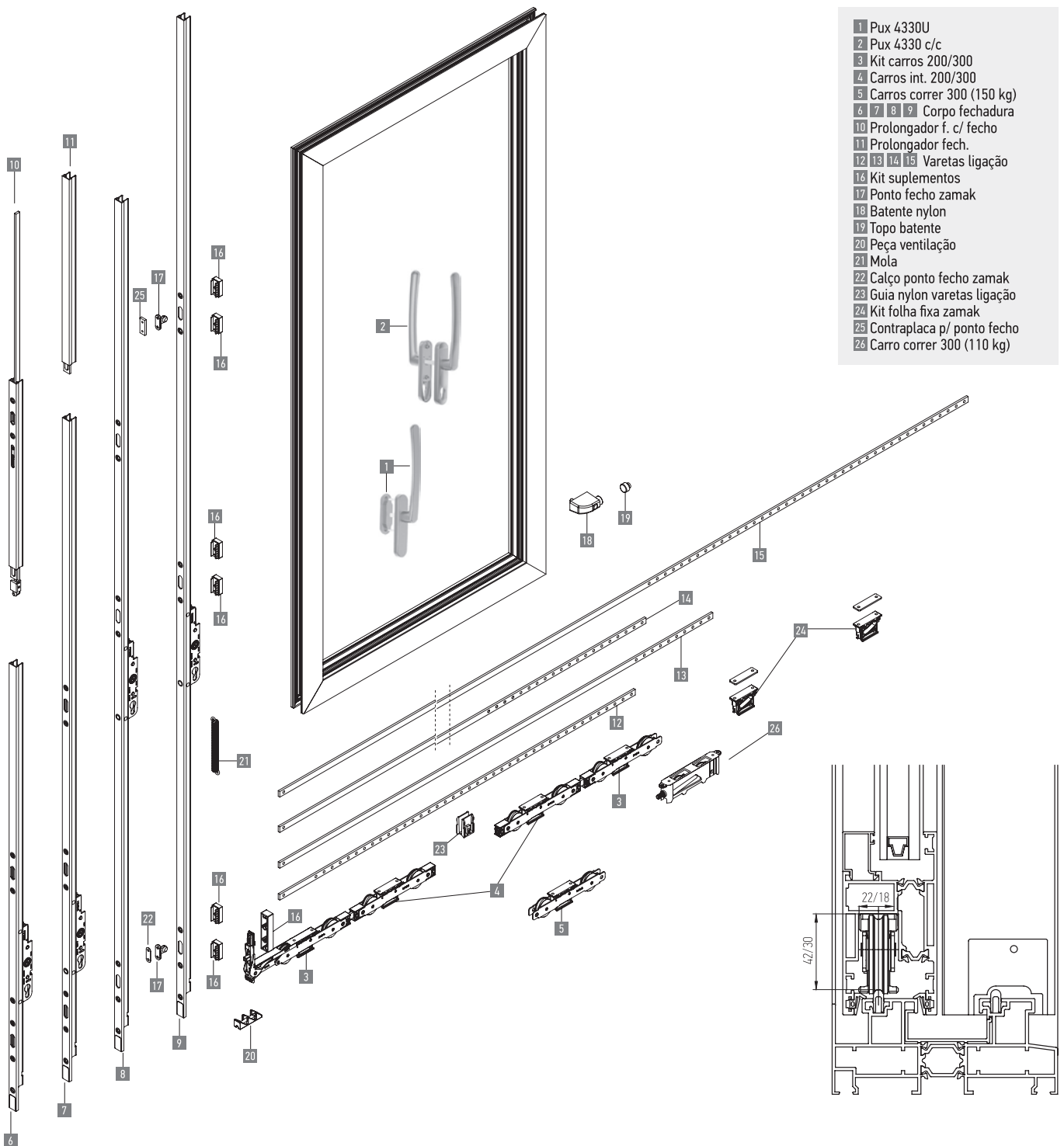

Esquema/Diagram/Schemá

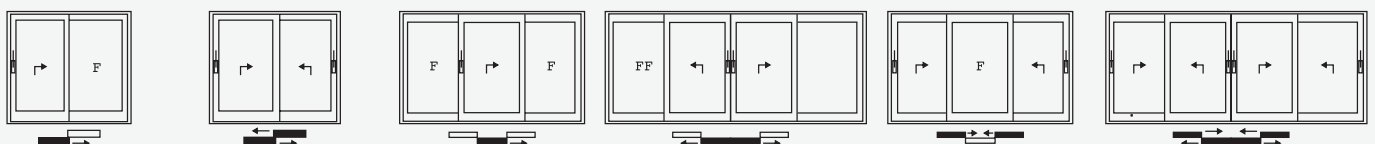

(A) 1 folha de correr - elevável / 1 fixa
1 hoja corredera-elevable / 1 fija
1 lift and slide sash / 1 fixed sash
1 vantail coulissant à levage / 1 fixe

(D) 2 folhas de correr - elevável
2 hojas corredera-elevable
2 lift and slide sashes
2 vantaux coulissants à levage

(G) 1 folha de correr - elevável / 2 fixas
1 hoja corredera-elevable / 2 fijas
1 lift and slide sash / 2 fixed sashes
1 vantail coulissant à levage / 2 fixes

(C) 2 folhas de correr - elevável / 2 fixas
2 hojas corredera-elevable / 2 fijas
2 lift and slide sash / 2 fixed sashes
2 vantaux coulissants à levage / 2 fixes

(H) 2 folhas de correr - elevável / 1 fixa
2 hojas corredera-elevable / 1 fija
2 lift and slide sash / 1 fixed sashes
2 vantaux coulissants à levage / 1 fixe

(F) 4 folhas de correr - elevável
4 hojas corredera-elevable
4 lift and slide sashes
4 vantaux coulissants à levage

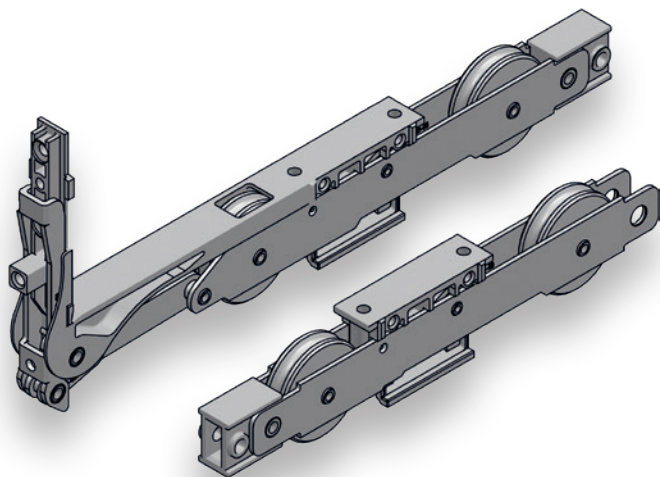

**KIT CARROS 300
(MR0045)**

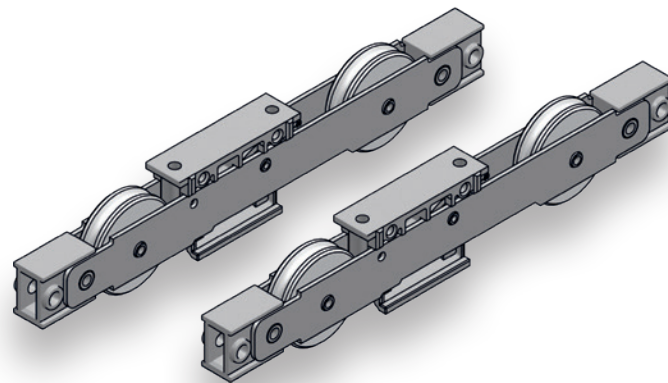

**KIT CARROS INTERMÉDIO 300
(MR0050)**

**EMBALAGEM - PACKAGING
EMPAQUETADO - EMBALLAGE**

1 kit por caixa
1 kit per box
1 kit por caja
1 kit par boîte

**MATERIAIS - MATERIALS
MATERIALES - MATERIAUX**

Zamak - Ferro - Nylon
Zamak - Iron - Nylon
Zamak - Hierro - Nylon
Zamak - Fer - Nylon

**FIXAÇÃO - FIXING
FIJACIÓN - FIXATION**

Parafusos incluídos
Screws included
Tornillos incluidos
Vis inclus

**ACABAMENTO - FINISHING
ACABADOS - FINITION**

Zincado c/ vibrado
Zinc with vibrated
Zincado con vibrado
Zinc avec vibré

**NORMA - STANDARD
NORMA - NORME**

EN 13126

KIT CARROS · BOGIES · JUEGO BÁSICO DE CARROS · JEU DE GALETS DE BASE

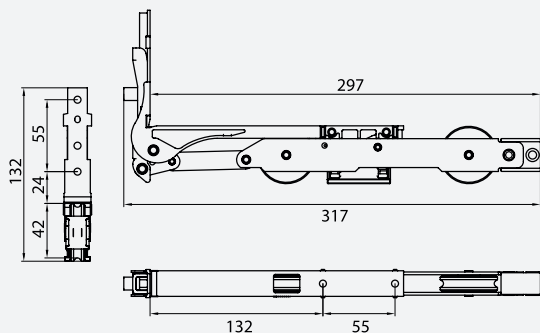

KIT CARROS 300

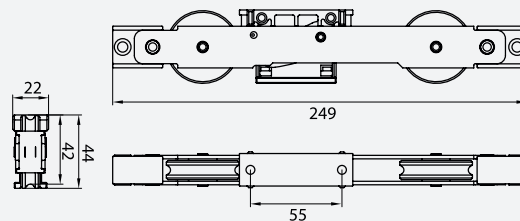
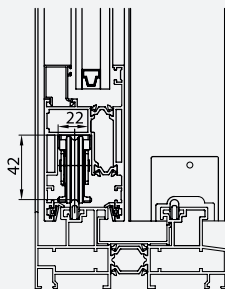

KIT CARROS INTERMÉDIO 300

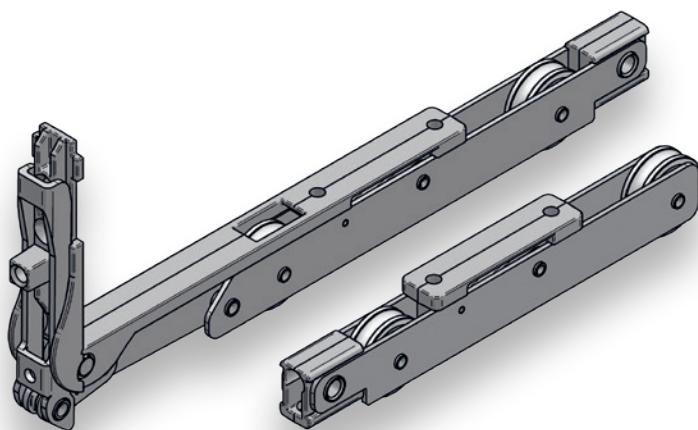

**KIT CARROS 200
(MR0020)**

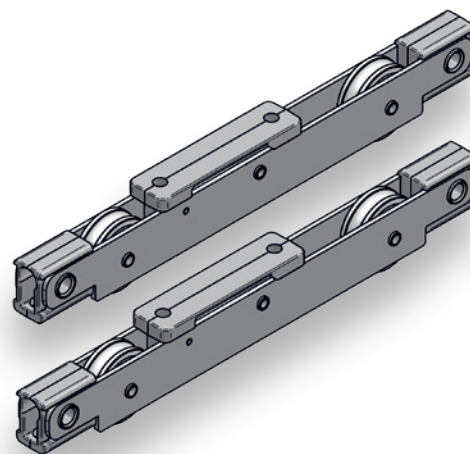

**KIT CARROS INTERMÉDIO 200
(MR0033)**

**EMBALAGEM - PACKAGING
EMPAQUETADO - EMBALLAGE**

1 kit por caixa
1 kit per box
1 kit por caja
1 kit par boîte

**MATERIAIS - MATERIALS
MATERIALES - MATERIAUX**

Zamak - Aço - Nylon
Zamak - Steel - Nylon
Zamak - Acero - Nylon
Zamak - Acier - Nylon

**FIXAÇÃO - FIXING
FIJACIÓN - FIXATION**

Parafusos incluídos
Screws included
Tornillos incluidos
Vis inclus

**ACABAMENTO - FINISHING
ACABADOS - FINITION**

Zincado c/ vibrado
Zinc with vibrated
Zincado con vibrado
Zinc avec vibré

**NORMA - STANDARD
NORMA - NORME**

EN 13126

KIT CARROS · BOGIES · JUEGO BÁSICO DE CARROS · JEU DE GALETS DE BASE

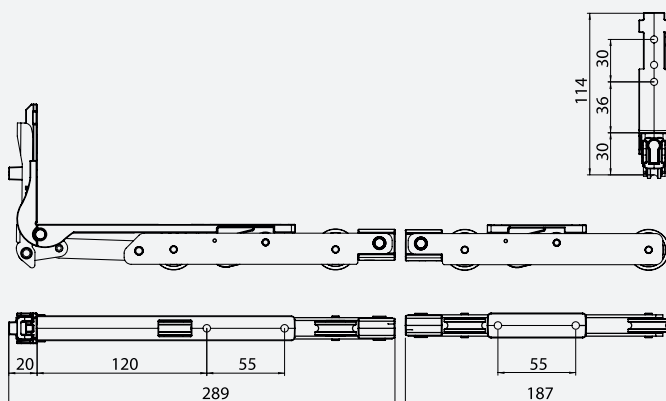

KIT CARROS 200

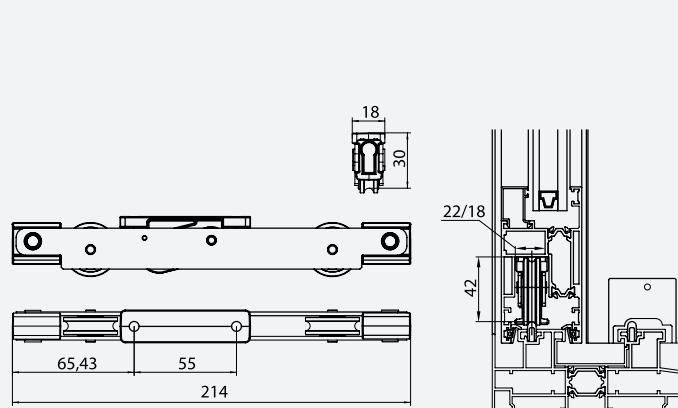

KIT CARROS INTERMÉDIO 200

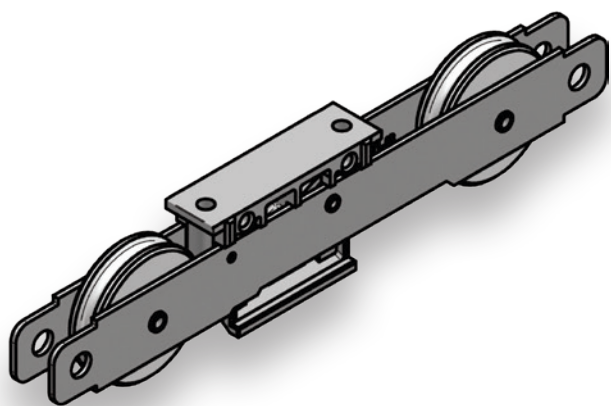

**CARRO CORRER 300
(MR0054)**

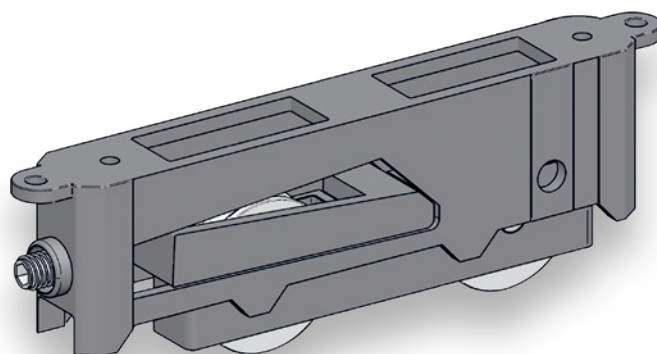

**CARRO CORRER 300
(MR0055)**

**EMBALAGEM - PACKAGING
EMPAQUETADO - EMBALLAGE**

1 kit por caixa
1 kit per box
1 kit por caja
1 kit par boîte

**MATERIAIS - MATERIALS
MATERIALES - MATERIAUX**

Zamak - Ferro - Nylon
Zamak - Iron - Nylon
Zamak - Hierro - Nylon
Zamak - Fer - Nylon

**FIXAÇÃO - FIXING
FIJACIÓN - FIXATION**

Parafusos incluídos
Screws included
Tornillos incluidos
Vis inclus

**ACABAMENTO - FINISHING
ACABADOS - FINITION**

Zincado c/ vibrado
Zinc with vibrated
Zincado con vibrado
Zinc avec vibré

**NORMA - STANDARD
NORMA - NORME**

EN 13126

**OBSERVAÇÕES - COMMENTS
OBSERVACIONES - OBSERVATIONS**

MR0054 - 2 carros x 150 kg = 300 kg
MR0055 - 2 carros x 110 kg = 220 kg

CARRO CORRER · ADDITIONAL BOGIE · CARRO PARA CORREDERA EN LÍNEA · JEU DE GALETS POUR COULISSANT EN LIGNE

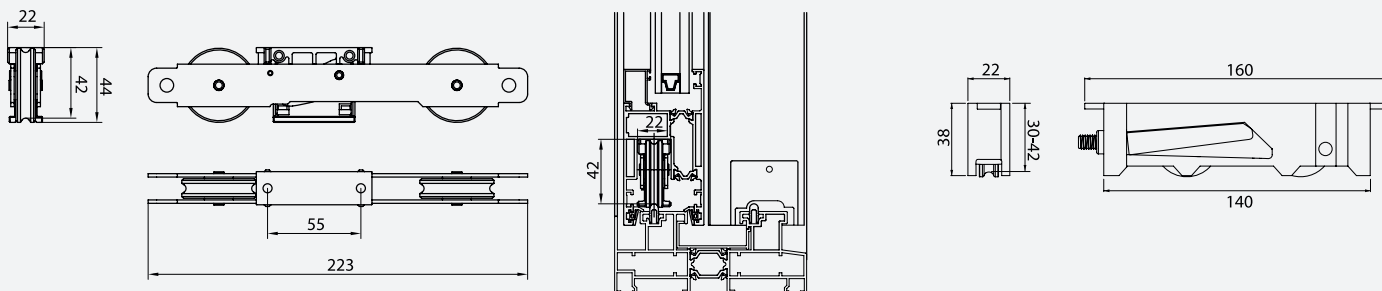

CORPO FECHADURA
GEAR (CREMONE)
FALLEBA (CREMONA)
GEAR (CRÉMONE)

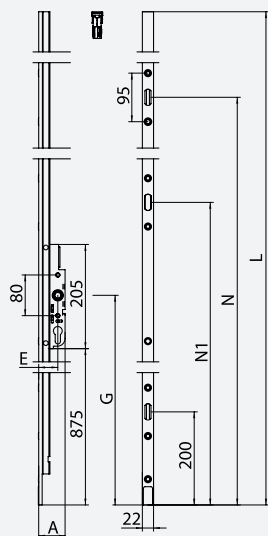
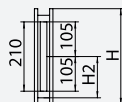
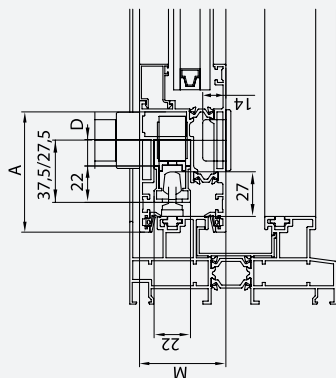

MEDIDAS JANELAS / PORTAS

	ELEV. 200 CF27,5 REF.	ELEV. 300 CF37,5 REF.	ALTURAS (mm)
CF1	MR0015	MR0040	750/1295
CF2	MR0016	MR0041	1165/1795
CF3	MR0017	MR0042	1795/2295
CF4	MR0018	MR0043	2045/2700

ref. ^a	L	E	G	A	N	N1
CF1-37,5	1190	37,5	400	52	650	-
CF1-27,5	1190	27,5	400	42	650	-
CF2-37,5	1770	37,5	400	52	1020	580
CF2-27,5	1770	27,5	400	42	1020	580
CF3-37,5	2270	37,5	900	52	1650	1180
CF3-27,5	2270	27,5	900	42	1650	1180
CF4-37,5	2670	37,5	900	52	1900	1180
CF4-27,5	2670	27,5	900	42	1900	1180

Quotas corpo fechadura
Mechanising for gears
Mecanizado para fallebas
Usinage pour espagnolettes



EMBALAGEM - PACKAGING
EMPAQUETADO - EMBALLAGE

1 unidade por caixa
1 unit per box
1 unidade por caixa
1 unit per box
1 unité par boîte

MATERIAIS - MATERIALS
MATERIALES - MATERIAUX

Zamak - Ferro - Nylon
Zamak - Iron - Nylon
Zamak - Hierro - Nylon
Zamak - Fer - Nylon

FIXAÇÃO - FIXING
FIJACIÓN - FIXATION

Parafusos incluídos
Screws included
Tornillos incluidos
Vis inclus

ACABAMENTO - FINISHING
ACABADOS - FINITION

Lacado / Anodizado
Powder painting / Anodized
Lacado / Anodizado
Laqué / Anodisé

NORMA - STANDARD
NORMA - NORME

EN 1670
EN 13126

- (1) MR0025
- (2) MR0026
- (3) MR0027
- (4) MR0028



**EMBALAGEM - PACKAGING
EMPAQUETADO - EMBALLAGE**

1 unidade por caixa
1 unit per box
1 unidade por caja
1 unité par boîte

**MATERIAIS - MATERIALS
MATERIALES - MATERIAUX**

Ferro
Iron
Hierro
Fer

**FIXAÇÃO - FIXING
FIJACIÓN - FIXATION**

Parafusos incluídos
Screws included
Tornillos incluidos
Vis inclus

**ACABAMENTO - FINISHING
ACABADOS - FINITION**

Zincado
Zinc
Zincado
Zinc

**NORMA - STANDARD
NORMA - NORME**

EN 13126

VARETAS LIGAÇÃO · CONNECTING RODS GUIAS · PLETINAS UNIÓN CARROS GUIDES · MÉPLATS UNION GALETS

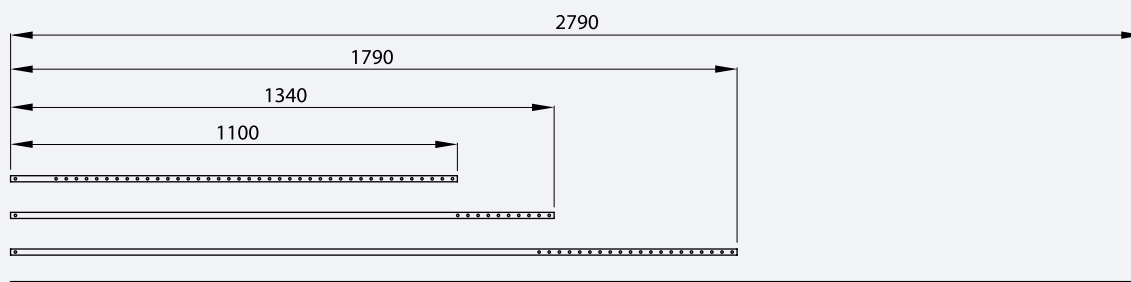

MEDIDAS JANELAS / PORTAS

REF.	VARETAS	LARGURA (mm)
MR0025	1100	700/1600
MR0026	1340	1600/1850
MR0027	1790	1851/2350
MR0028	2790	2351/3300

KIT SUPLEMENTOS
SUPPLEMENTS FOR GEAR
SUPLEMENTOS DE FALLEBA
SUPPLÉMENTS D'ESPAGNOLETTE

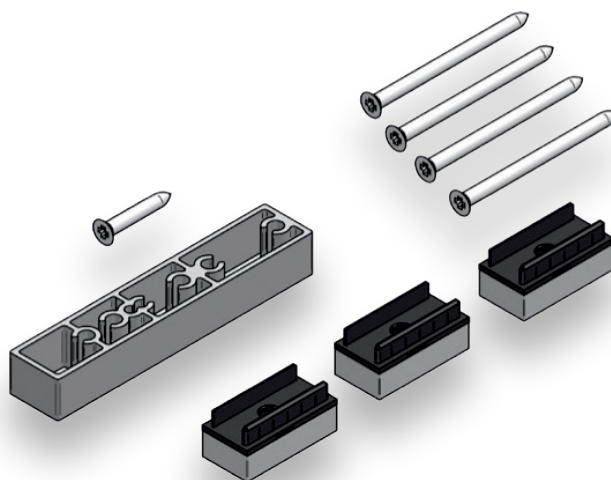
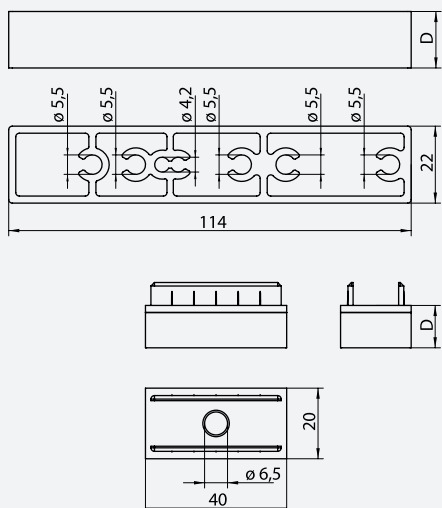

KIT SUPLEMENTOS CF 1

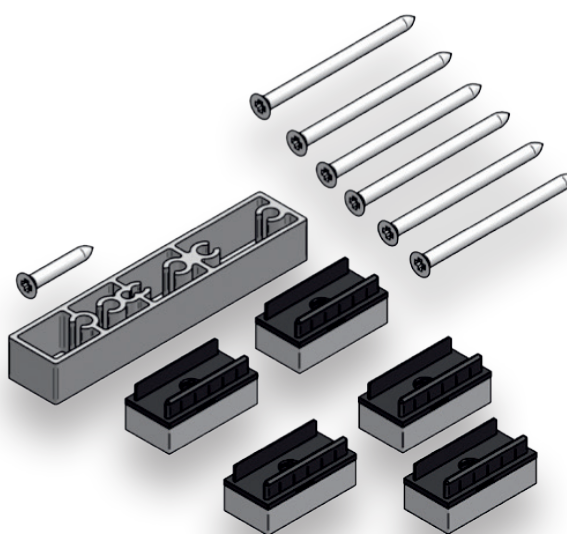

KIT SUPLEMENTOS CF 2/3/4

EMBALAGEM - PACKAGING
EMPAQUETADO - EMBALLAGE

1 unidade por caixa
1 unit per box
1 unidade por caja
1 unité par boîte

MATERIAIS - MATERIALS
MATERIALES - MATERIAUX

Zamak - Aço - Nylon
Zamak - Steel - Nylon
Zamak - Acero - Nylon
Zamak - Acier - Nylon

FIXAÇÃO - FIXING
FIJACIÓN - FIXATION

Parafusos incluídos
Screws included
Tornillos incluidos
Vis inclus

ACABAMENTO - FINISHING
ACABADOS - FINITION

Zincado
Zinc
Zincado
Zinc

NORMA - STANDARD
NORMA - NORME

EN 13126

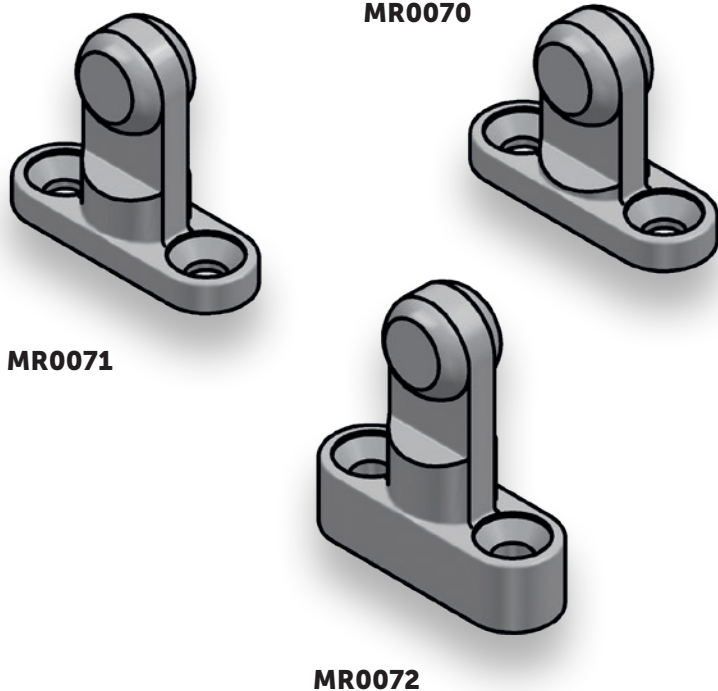

MR0071

MR0070

MR0072

PONTOS FECHO ZAMAK
LOCKING POINTS FOR LIFT AND SLIDE FITTING
PUNTOS DE CIERRE CORREDERA ELEVABLE
POINTS DE FERMETURE POUR COULISSANT À LEVAGE

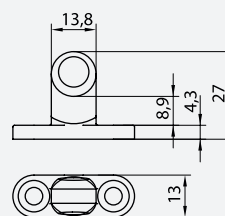

MR0070

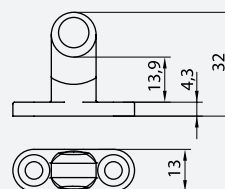

MR0071

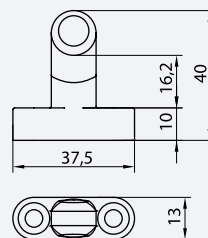

MR0072

EMBALAGEM - PACKAGING
EMPAQUETADO - EMBALLAGE

1 unidade por caixa
1 unit per box
1 unidade por caja
1 unité par boîte

MATERIAIS - MATERIALS
MATERIALES - MATERIAUX

Zamak - Aço - Nylon
Zamak - Steel - Nylon
Zamak - Acero - Nylon
Zamak - Acier - Nylon

FIXAÇÃO - FIXING
FIJACIÓN - FIXATION

Parafusos incluídos
Screws included
Tornillos incluidos
Vis inclus

ACABAMENTO - FINISHING
ACABADOS - FINITION

Zincado
Zinc
Zincado
Zinc

NORMA - STANDARD
NORMA - NORME

EN 13126

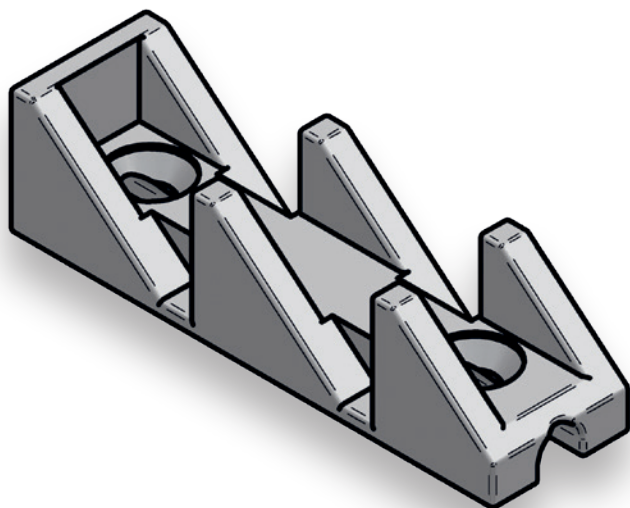

**PEÇA VENTILAÇÃO
(MR0077)**

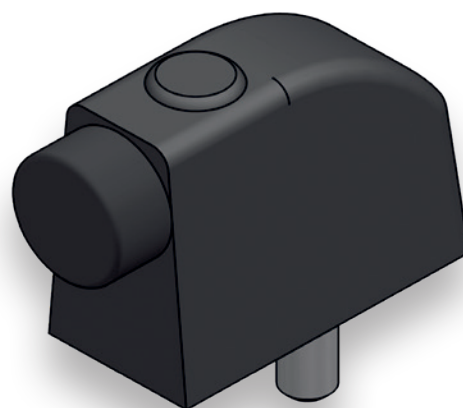

**BATENTE NYLON
(MR0075 - PRETO)
(MR0076 - BRANCO)**



**TOPO NYLON
(MR0073 - PRETO)
(MR0074 - BRANCO)**

**EMBALAGEM - PACKAGING
EMPAQUETADO - EMBALLAGE**

1 unidade por caixa
1 unit per box
1 unidade por caja
1 unité par boîte

**MATERIAIS - MATERIALS
MATERIALES - MATERIAUX**

Zamak - Nylon
Zamak - Nylon
Zamak - Nylon
Zamak - Nylon

**FIXAÇÃO - FIXING
FIJACIÓN - FIXATION**

Parafusos incluídos
Screws included
Tornillos incluidos
Vis inclus

**ACABAMENTO - FINISHING
ACABADOS - FINITION**

Zincado
Zinc
Zincado
Zinc

**NORMA - STANDARD
NORMA - NORME**

EN 13126

PEÇA VENTILAÇÃO · VENTILATION LIMITER · DELIMITADOR DE VENTILACIÓN · LIMITEUR D'AÉRATION

BATENTE NYLON · SASH BUFFER 90 + SHOCK ABSORBER · TOPE 90 + AMORTIGUADOR · BUTÉE D'ARRÊT 90 + AMORTISSEUR BUTÉE

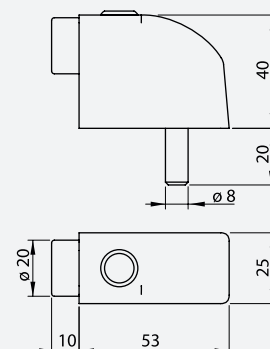
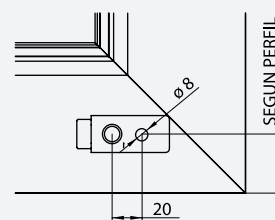
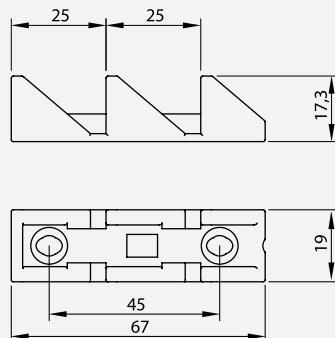
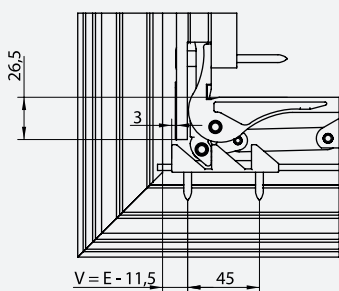

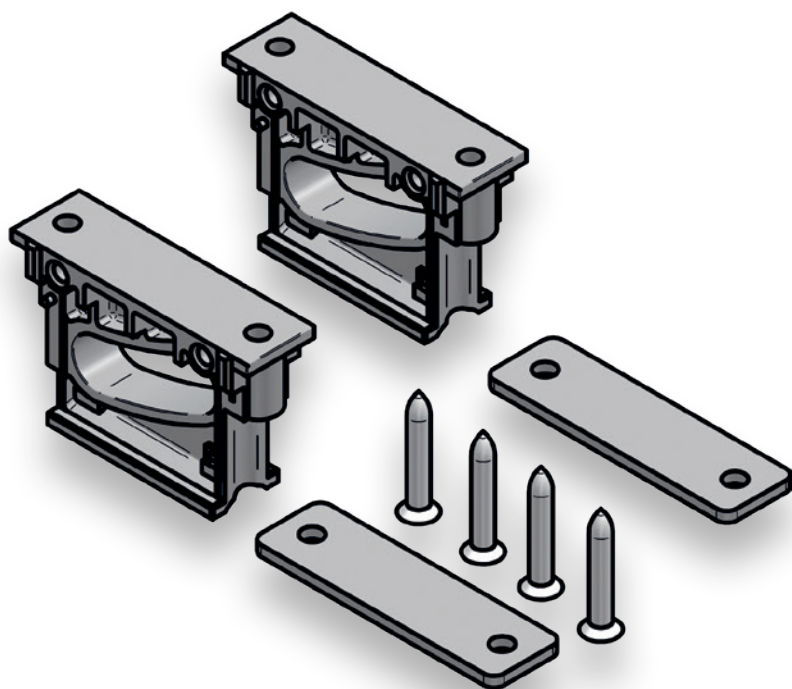

**KIT FOLHA FIXA 300
(MR0060)**

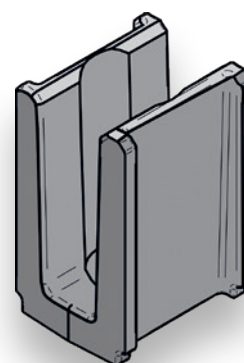

**GUIA NYLON 200
(MR0030)**

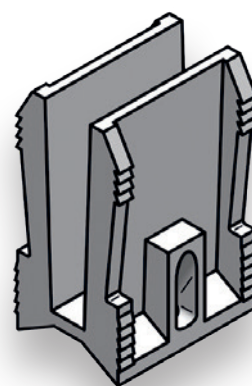

**GUIA NYLON 300
(MR0047)**

**EMBALAGEM - PACKAGING
EMPAQUETADO - EMBALLAGE**

1 unidade por caixa
1 unit per box
1 unidade por caja
1 unité par boîte

**MATERIAIS - MATERIALS
MATERIALES - MATERIAUX**

Zamak - Aço - Nylon
Zamak - Steel - Nylon
Zamak - Acero - Nylon
Zamak - Acier - Nylon

**FIXAÇÃO - FIXING
FIJACIÓN - FIXATION**

Parafusos incluídos
Screws included
Tornillos incluidos
Vis inclus

**ACABAMENTO - FINISHING
ACABADOS - FINITION**

Zincado
Zinc
Zincado
Zinc

**NORMA - STANDARD
NORMA - NORME**

EN 13126

KIT FOLHA FIXA · CT-SUPPLEMENTS FOR FIXED SASH · CT-SUPLEMENTOS PARA HOJA FIJA · CT-SUPPLÉMENTS POUR VANTAIL FIXE
GUIA NYLON · CONNECTING RODS GUIDE · GUÍA PLETINA UNIÓN · GUIDE MÉPLAT UNION

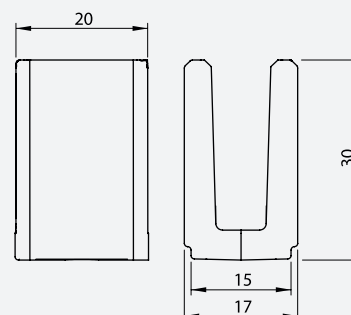
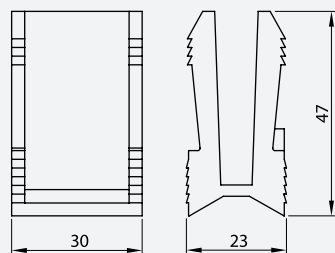
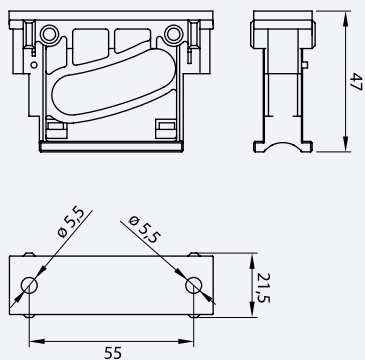



**PROLONGADOR
C/ FECHO (MR0063)**



**PROLONGADOR
(MR0064)**

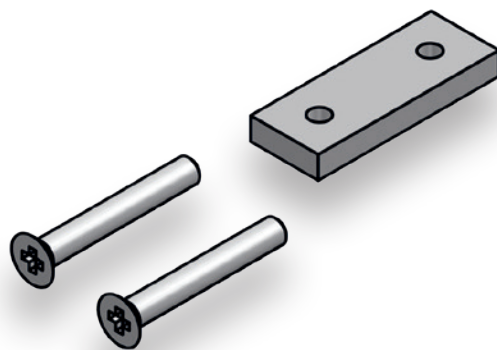

**CONTRAPLACA
PONTO FECHO
(MR0061)**



**CALÇO PONTO FECHO
(MR0069)**

**EMBALAGEM - PACKAGING
EMPAQUETADO - EMBALLAGE**

1 unidade por caixa
1 unit per box
1 unidade por caja
1 unité par boîte

**MATERIAIS - MATERIALS
MATERIALES - MATERIAUX**

Alumínio - Zamak - Inox
Alluminium - Zamak - Stainless Steel
Aluminio - Zamak - Acero Inox
Alluminium - Zamak - Inox

**FIXAÇÃO - FIXING
FIJACIÓN - FIXATION**

Parafusos incluídos
Screws included
Tornillos incluidos
Vis inclus

**ACABAMENTO - FINISHING
ACABADOS - FINITION**

Zincado
Zinc
Zincado
Zinc

**NORMA - STANDARD
NORMA - NORME**

EN 13126

PROLONGADORES · EXTRA GEAR LENGTH · PROLONGACIONES FALLEBA · PROLONGEMENTS ESPAGNOLETTE
CONTRAPLACA PONTO FECHO · CT-COUNTER-PLATE DIAGRAM C AND F · CT-CONTRAPLACA ESQUEMA C Y F · CT-CONTREPLAQUE SCHÉMA C ET F
CALÇO PONTO FECHO · LOCKING BOLT SUPPLEMENT · SUPLEMENTO BULÓN CIERRE · SUPPLÉMENT BOULON FERMETURE

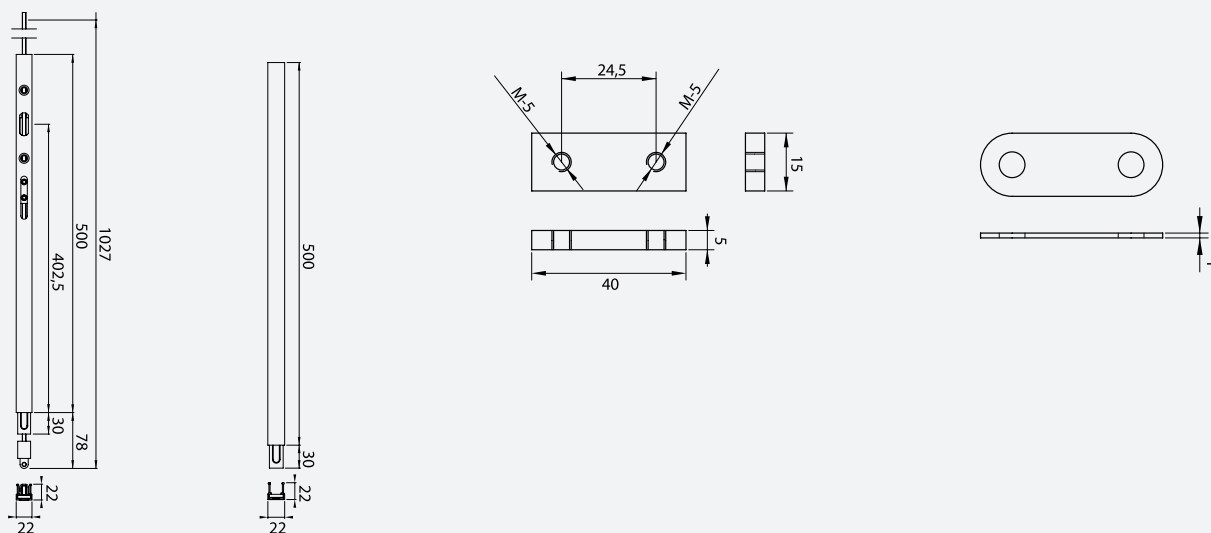



ASSA ABLOY





SISTEMAS DE CORRER

SLIDING SYSTEMS

SISTEMAS DE CORRER

SYSTÈME COULISSANT

ÁGUEDA

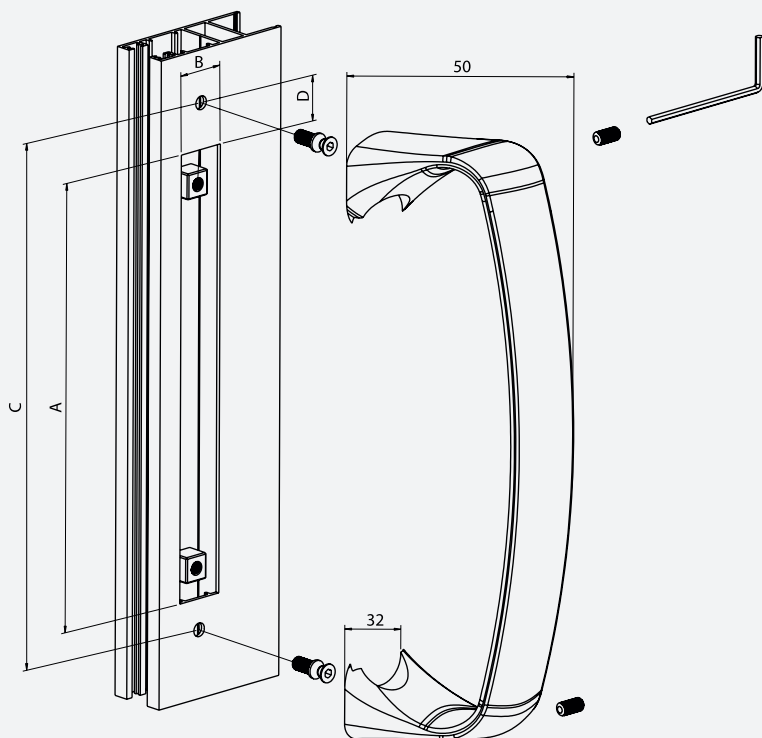

REF.	A	B	C	D
4308	184	19,5	208,5	14,7
4309	172	19,5	208,5	25,8
2172	149	20	208,5	27,3

**EMBALAGEM - PACKAGING
EMPAQUETADO - EMBALLAGE**

12 unidades por caixa
12 pieces per box
12 unidades por caja
12 pieces par boîte

**MATERIAIS - MATERIALS
MATERIALES - MATERIAUX**

Alumínio injectado
Injected aluminium
Alumínio injectado
Aluminium injecté

**FIXAÇÃO - FIXING
FIJACIÓN - FIXATION**

Kit incluído
Kit included
Kit incluído
Kit inclus

**ACABAMENTO - FINISHING
ACABADOS - FINITION**

Lacado
Powder painting
Lacado
Laqué

**NORMA - STANDARD
NORMA - NORME**

EN 1670

FECHO LATERAL DE EMBUTIR
LATERAL INSERT BARREL
CIERRE DE EMBUTIR
VERROU COULISSE

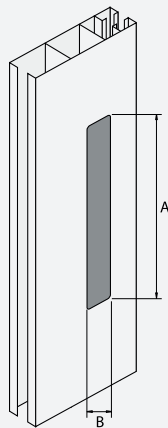
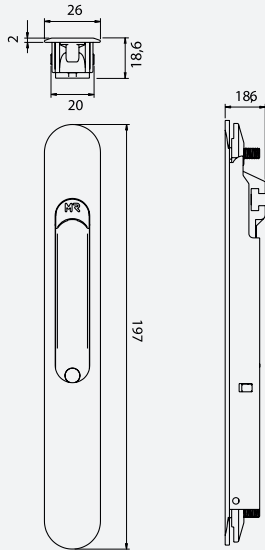

REF.	(A)	(B)
4308	184	19,5
4309	173	19,5

Microventilação de correr

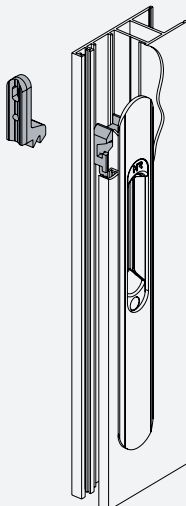

Fixação invisível
4309



4309
4309 TR



4308
4308 TR

EMBALAGEM - PACKAGING
EMPAQUETADO - EMBALLAGE

50 unidades por caixa
50 pieces per box
50 unidades por caja
50 pieces par boîte

MATERIAIS - MATERIALS
MATERIALES - MATERIAUX

Alumínio - Zamak - Inox
Alluminium - Zamak - Stainless Steel
Aluminio - Zamak - Acero Inox
Alluminium - Zamak - Inox

FIXAÇÃO - FIXING
FIJACIÓN - FIXATION

Parafusos incluídos
Screws included
Tornillos incluídos
Vis inclus

ACABAMENTO - FINISHING
ACABADOS - FINITION

Lacado
Powder painting
Lacado
Laqué

NORMA - STANDARD
NORMA - NORME

EN 1670
EN 13126

OBSERVAÇÕES - COMMENTS
OBSERVACIONES - OBSERVATIONS

4308 TR / 4309 TR
Fechos com travão

4308 P



FECHO LATERAL DE EMBUTIR
LATERAL INSERT BARREL
CIERRE DE EMBUTIR
VERROU COULISSE

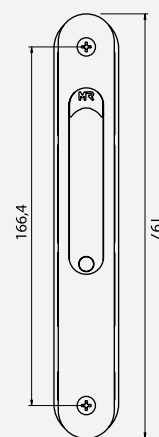
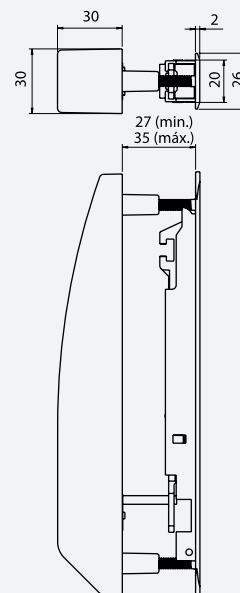

EMBALAGEM - PACKAGING
EMPAQUETADO - EMBALLAGE

15 unidades por caixa
15 pieces per box
15 unidades por caja
15 pieces par boîte

MATERIAIS - MATERIALS
MATERIALES - MATERIAUX

Alumínio - Zamak - Inox
Alluminium - Zamak - Stainless Steel
Aluminio - Zamak - Acero Inox
Alluminium - Zamak - Inox

FIXAÇÃO - FIXING
FIJACIÓN - FIXATION

Parafusos incluídos
Screws included
Tornillos incluidos
Vis inclus

ACABAMENTO - FINISHING
ACABADOS - FINITION

Lacado
Powder painting
Lacado
Laqué

NORMA - STANDARD
NORMA - NORME

EN 1670
EN 13126

FECHO LATERAL DE EMBUTIR
LATERAL INSERT BARREL
CIERRE DE EMBUTIR
VERROU COULISSE

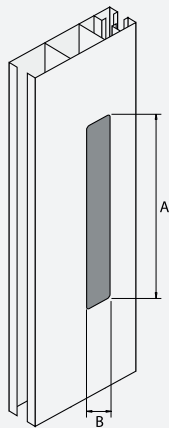
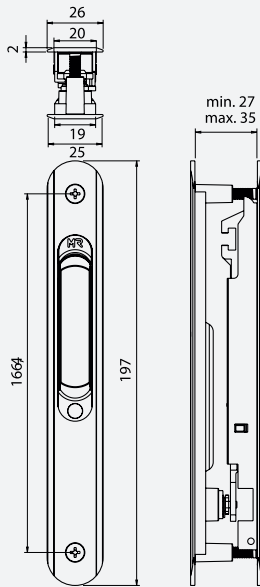

REF.	(A)	(B)
4308	184	19,5
4309	173	19,5



Fixação invisível
4309 C



DUPLO
4309 C



4309 C DUPLO



4309 C



4308 C

EMBALAGEM - PACKAGING
EMPAQUETADO - EMBALLAGE

50 unidades por caixa
50 pieces per box
50 unidades por caja
50 pieces par boîte

MATERIAIS - MATERIALS
MATERIALES - MATERIAUX

Alumínio - Zamak - Inox
Alluminium - Zamak - Stainless Steel
Aluminio - Zamak - Acero Inox
Alluminium - Zamak - Inox

FIXAÇÃO - FIXING
FIJACIÓN - FIXATION

Parafusos incluídos
Screws included
Tornillos incluidos
Vis inclus

ACABAMENTO - FINISHING
ACABADOS - FINITION

Lacado
Powder painting
Lacado
Laqué

NORMA - STANDARD
NORMA - NORME

EN 1670
EN 13126

OBSERVAÇÕES - COMMENTS
OBSERVACIONES - OBSERVATIONS

4308 C - 4309 C Duplo
25 unidades por caixa
25 pieces per box
25 unidades por caja
25 pieces par boîte

4308 C
chaves diferentes · different keys
llaves diferentes · différentes clés

4309 C
chaves iguais · same keys
llaves iguales · mêmes clés



2172



2150



2170 / 2171

**EMBALAGEM - PACKAGING
EMPAQUETADO - EMBALLAGE**

50 unidades por caixa
50 pieces per box
50 unidades por caja
50 pieces par boîte

**MATERIAIS - MATERIALS
MATERIALES - MATERIAUX**

Alumínio - Zamak - Inox
Alluminium - Zamak - Stainless Steel
Aluminio - Zamak - Acero Inox
Alluminium - Zamak - Inox

**FIXAÇÃO - FIXING
FIJACIÓN - FIXATION**

Parafusos incluídos
Screws included
Tornillos incluidos
Vis inclus

**ACABAMENTO - FINISHING
ACABADOS - FINITION**

Lacado
Powder painting
Lacado
Laqué

**NORMA - STANDARD
NORMA - NORME**

EN 1670
EN 13126

**OBSERVAÇÕES - COMMENTS
OBSERVACIONES - OBSERVATIONS**

2170/ 2150 - c/ mola
2171/ 2151 - s/ mola (manual)

FECHO LATERAL DE EMBUTIR · LATERAL INSERT BARREL · CIERRE DE EMBUTIR · VERROU COULISSE

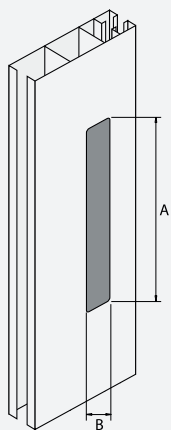

REF.	(A)	(B)
2170	146	19,5
2172	149	20
2150	146	19,5

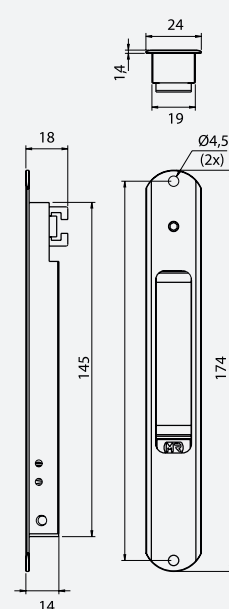
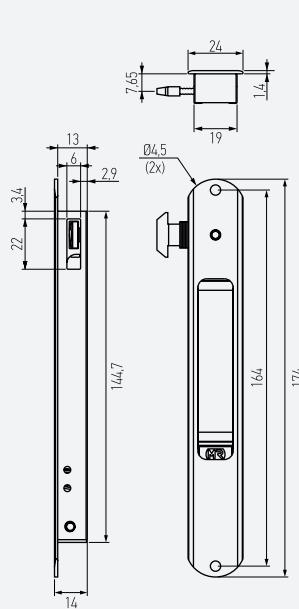
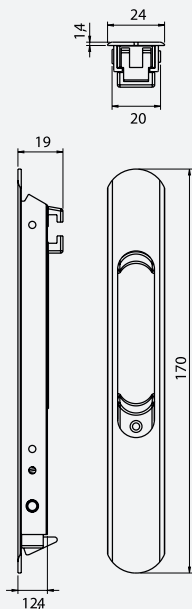



4350



UNHEIRO 4309



4210 / 4310

**EMBALAGEM - PACKAGING
EMPAQUETADO - EMBALLAGE**

50 unidades por caixa
50 pieces per box
50 unidades por caja
50 pieces par boîte

**MATERIAIS - MATERIALS
MATERIALES - MATERIAUX**

Alumínio - Zamak - Inox
Alluminium - Zamak - Stainless Steel
Aluminio - Zamak - Acero Inox
Alluminium - Zamak - Inox

**FIXAÇÃO - FIXING
FIJACIÓN - FIXATION**

Parafusos incluídos
Screws included
Tornillos incluidos
Vis inclus

**ACABAMENTO - FINISHING
ACABADOS - FINITION**

Lacado
Powder painting
Lacado
Laqué

**NORMA - STANDARD
NORMA - NORME**

EN 1670
EN 13126

**OBSERVAÇÕES - COMENTS
OBSERVACIONES - OBSERVATIONS**

4210 / 4310 / 4350
24 unidades por caixa
24 pieces per box
24 unidades por caja
24 pieces par boîte

FECHO LATERAL DE EMBUTIR · LATERAL INSERT BARREL · CIERRE DE EMBUTIR · VERROU COULISSE

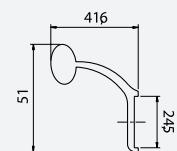
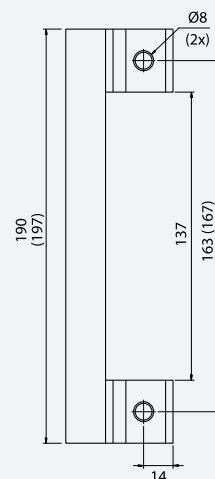
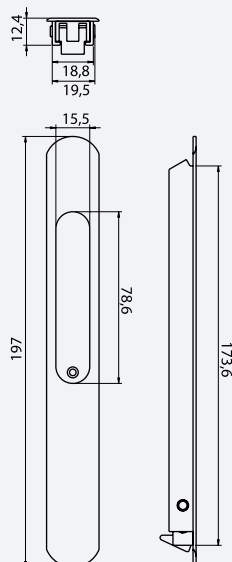
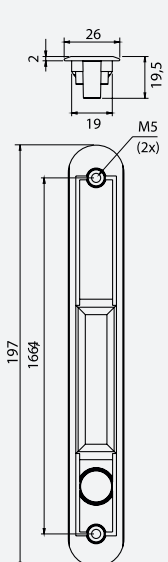

4310: 167mm
4210: 163mm

4310 → 4308
4210 → 2150 / 2170

8000



FECHO CENTRAL
CENTRAL HANDLE
CIERRE CENTRAL
POIGNÉE CENTRALE

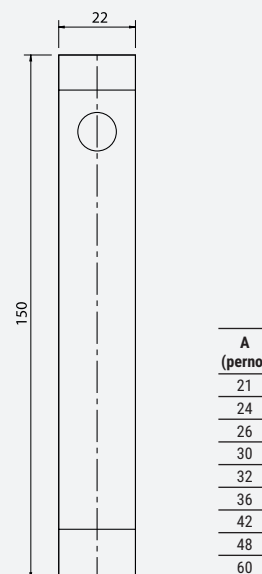

2959

Batente Séries de Correr

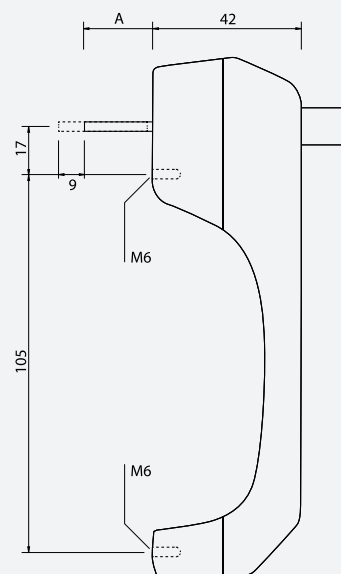

EMBALAGEM - PACKAGING
EMPAQUETADO - EMBALLAGE

12 unidades por caixa
12 pieces per box
12 unidades por caja
12 pieces par boîte

MATERIAIS - MATERIALS
MATERIALES - MATERIAUX

Alumínio - Nylon - Inox
Alluminium - Nylon - Stainless Steel
Aluminio - Nylon - Acero Inox
Alluminium - nylon - Inox

FIXAÇÃO - FIXING
FIJACIÓN - FIXATION

Parafusos incluídos
Screws included
Tornillos incluidos
Vis inclus

ACABAMENTO - FINISHING
ACABADOS - FINITION

Lacado
Powder painting
Lacado
Laqué

NORMA - STANDARD
NORMA - NORME

EN 1670
EN 13126

OBSERVAÇÕES - COMMENTS
OBSERVACIONES - OBSERVATIONS

2959
150 unidades por caixa
150 pieces per box
150 unidades por caja
150 pieces par boîte

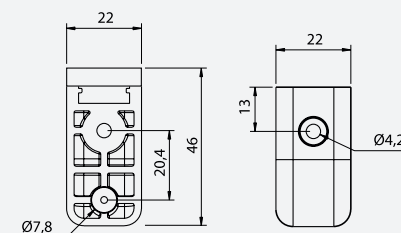

FECHO LATERAL 3 PUNTOS
3 POINTS SIDE LOCK
CIERRE LATERAL 3 PUNTOS
VERROU LATÉRAL 3 POINTS

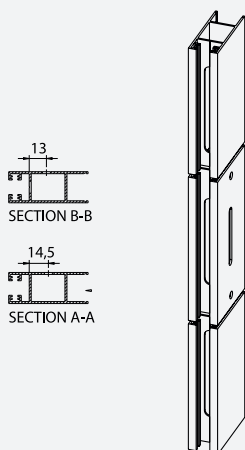
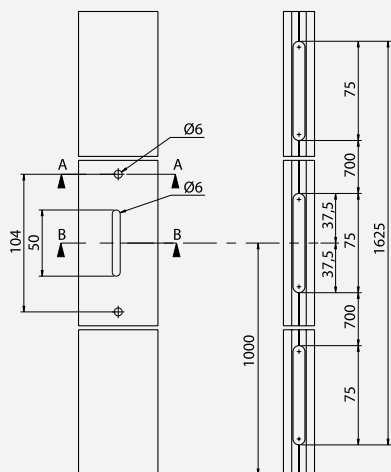

4220	MR
4220 1P	MR (1 ponto)
9540	Prestige
9540 1P	Prestige (1 ponto)
9541	Prestige (pega comprida)
9540 C	Prestige (c/ chave)
5540	Quad
5540 C	Quad (1 ponto)
5540 1P	Quad
5540 C 1P	Quad (1 ponto)

Cremone 2010/36
Kit 2034

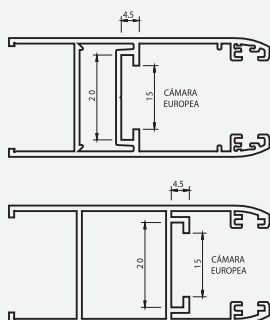

EMBALAGEM - PACKAGING
EMPAQUETADO - EMBALLAGE

6 unidades por caixa
6 pieces per box
6 unidades por caja
6 pieces par boîte

ACABAMENTO - FINISHING
ACABADOS - FINITION

Lacado
Powder painting
Lacado
Laqué

MATERIAIS - MATERIALS
MATERIALES - MATERIAUX

Alumínio - Zamak - Inox
Alluminium - Zamak - Stainless Steel
Aluminio - Zamak - Acero Inox
Alluminium - Zamak - Inox

NORMA - STANDARD
NORMA - NORME

EN 1670
EN 13126

FIXAÇÃO - FIXING
FIJACIÓN - FIXATION

Parafusos incluídos
Screws included
Tornillos incluidos
Vis inclus

OBSERVAÇÕES - COMENTS
OBSERVACIONES - OBSERVATIONS

K2034
100 unidades por caixa
100 pieces per box
100 unidades por caja
100 pieces par boîte

Varetas incluídas
Rods Included
Varillas incluidas
Tiges Inclus

4308 / 4309

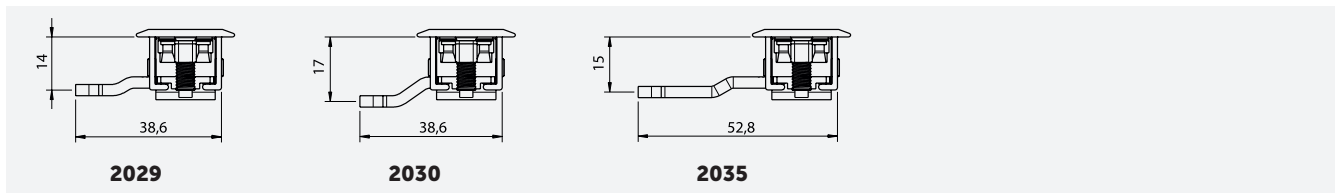

2029
 GRAMPO INOX
 emb. 50 un.

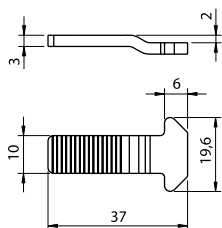
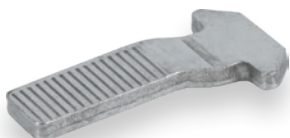

2030
 GRAMPO INOX
 emb. 50 un.

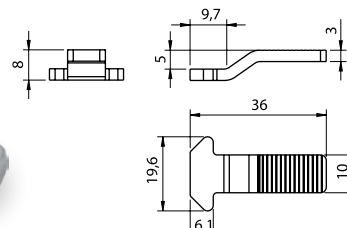
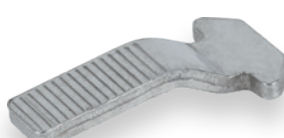

2033
 GRAMPO INOX
 emb. 50 un.

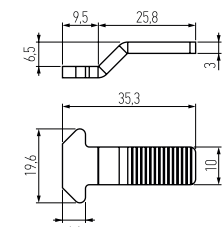

4307G
 PEÇA ZAMAK PERIMETRAL
 emb. 50 un.

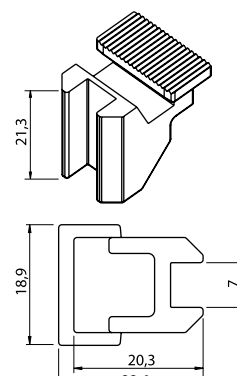

2035
 GRAMPO INOX
 emb. 50 un.

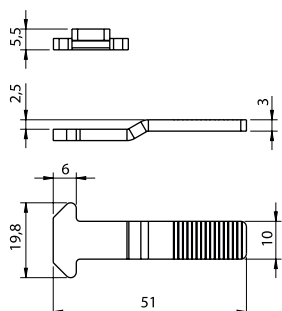

09769
 PEÇA ZAMAK MICRO DE CORRER
 emb. 50 un.

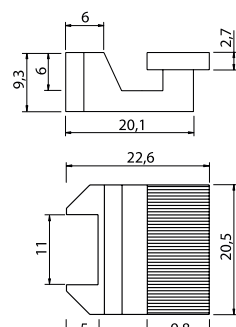
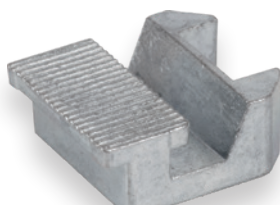

4307
 PEÇA ZAMAK PERIMETRAL
 emb. 50 un.

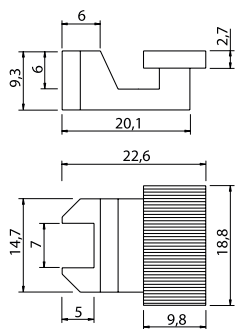
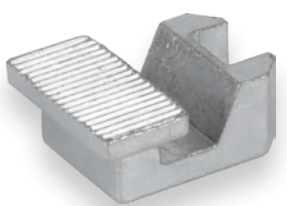

2170⁽¹⁾ / 2172⁽²⁾

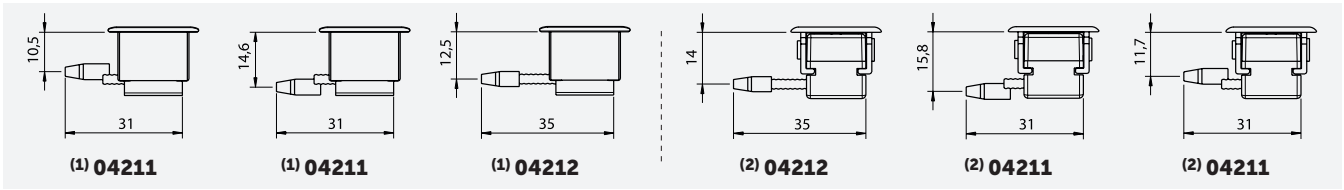

04212
GRAMPO ZAMAK
emb. 50 un.

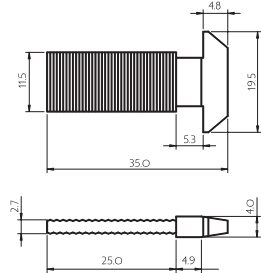
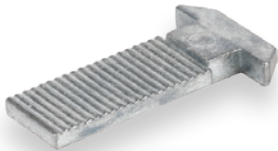

04211
GRAMPO ZAMAK
emb. 50 un.

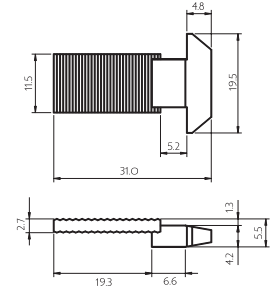

2172

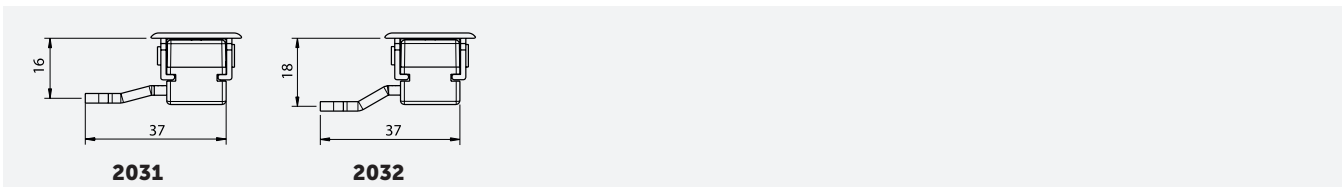

2031
GRAMPO INOX
emb. 50 un.

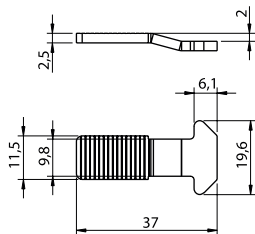
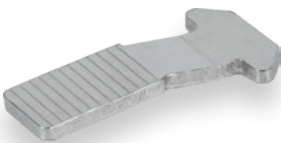

2032
GRAMPO INOX
emb. 50 un.

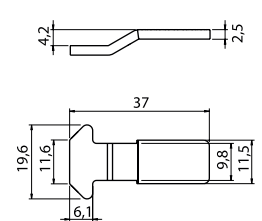
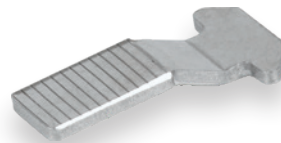

4307
PEÇA ZAMAK PERIMETAL
emb. 50 un.

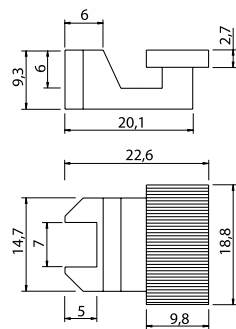

09769
PEÇA ZAMAK MICRO DE CORRER
emb. 50 un.

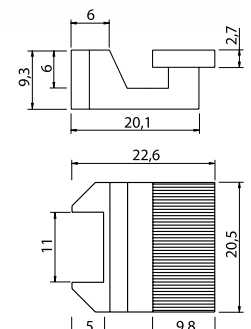

E-P
GRAMPO ZAMAK MICRO
emb. 50 un.

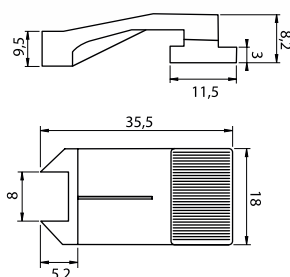
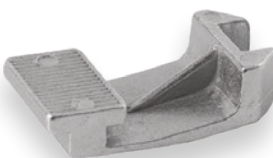

9060
 ENGATE ZAMAK
 emb. 50 un.

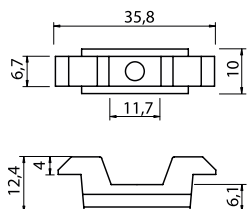
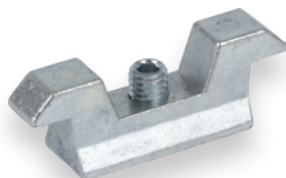

9770
 ENGATE MICRO DE CORRER
 emb. 50 un.

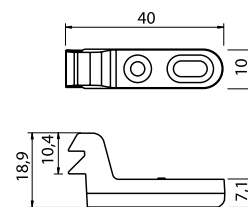

SW3 - 03174
 ENGATE ZAMAK
 emb. 50 un.

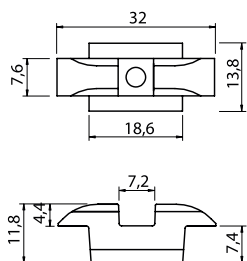

TV3 - 00048
 ENGATE ZAMAK
 emb. 50 un.

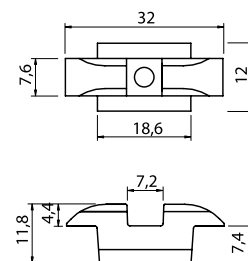

10047
 TESTA INOX 1.5
 emb. 50 un.

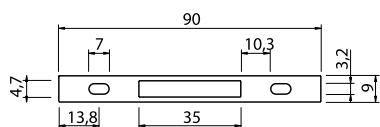

2002
 ENGATE ZAMAK
 emb. 50 un.

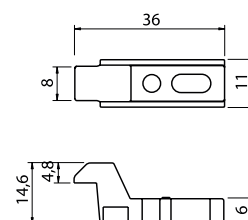
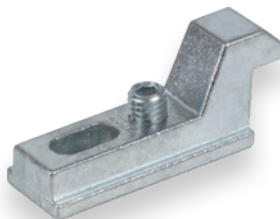

2003
 ENGATE ZAMAK
 emb. 50 un.

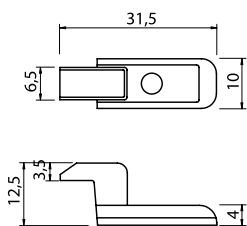

2004
 ENGATE ZAMAK
 emb. 50 un.

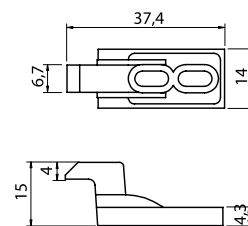

2005
 ENGATE ZAMAK
 emb. 50 un.

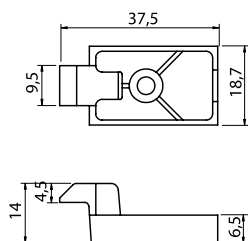

2006
 ENGATE ZAMAK
 emb. 50 un.

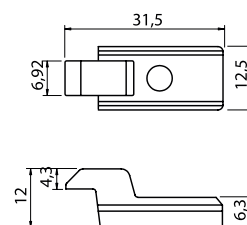

2021
 ENGATE ZAMAK
 emb. 50 un.

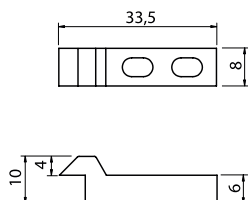

2022
 ENGATE ZAMAK
 emb. 50 un.

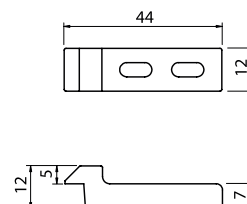
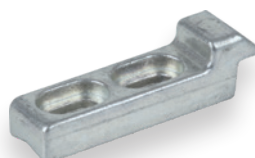

2026
 ENGATE ZAMAK
 emb. 50 un.

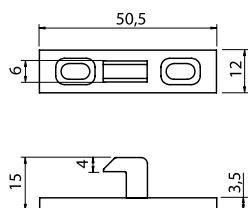

4301
 PEÇA ZAMAK PERIMETRAL
 emb. 50 un.

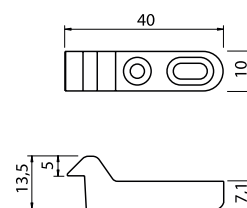

4302
 PEÇA ZAMAK PERIMETRAL
 emb. 50 un.

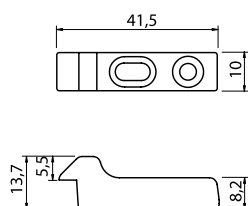

S-67
 ENGATE ZAMAK
 emb. 50 un.

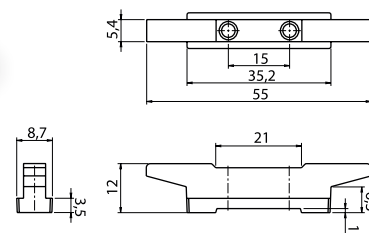
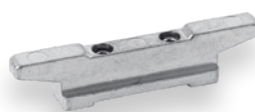



ASSA ABLOY



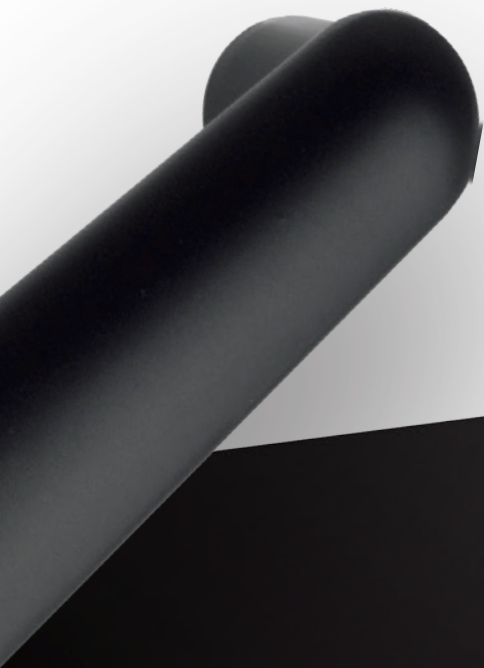

ASAS E PUXADORES DE PORTA

HANDLES AND DOOR HANDLES

ASAS Y TIRADORES DE PUERTA

POIGNÉES ET POIGNÉES DE PORTE

BOOM

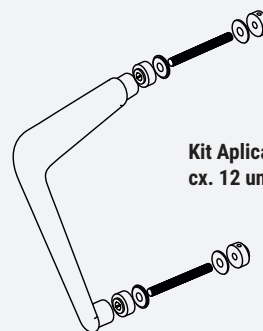
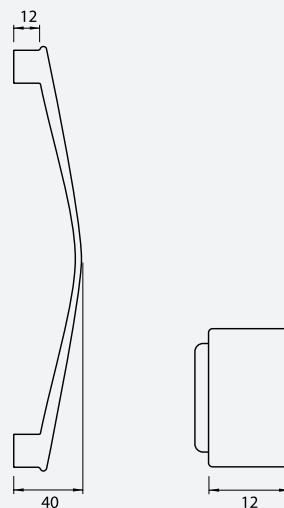
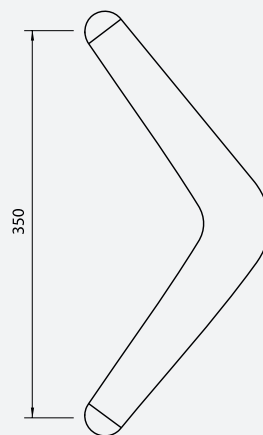

Kit Aplicação Simples
cx. 12 un.

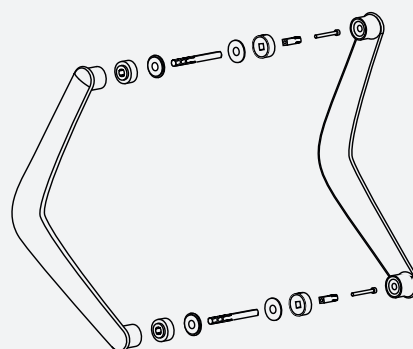

Kit Aplicação Dupla
(incluído)

EMBALAGEM - PACKAGING
EMPAQUETADO - EMBALLAGE

1 par por caixa
1 pair per box
1 par por caja
1 pair par boîte

NORMA - STANDARD
NORMA - NORME

EN 1670

MATERIAIS - MATERIALS
MATERIALES - MATERIAUX

Alumínio injectado
Injected aluminium
Alumínio injectado
Aluminium injecté

ACABAMENTO - FINISHING
ACABADOS - FINITION

Lacado
Powder painting
Lacado
Laqué



ASA "H"



ASA "V"



ASA "R"

EMBALAGEM - PACKAGING
EMPAQUETADO - EMBALLAGE

1 unidade por caixa
1 piece per box
1 unidade por caja
1 piece par boîte

MATERIAIS - MATERIALS
MATERIALES - MATERIAUX

Inox (304)
Stainless steel (304)
Acero inox (304)
Inox (304)

NORMA - STANDARD
NORMA - NORME

EN 1670

OBSERVAÇÕES - COMENTS
OBSERVACIONES - OBSERVATIONS

Kit aplicação simples - não incluído · not included · no incluido · non incluse
Kit aplicação dupla - não incluído · not included · no incluido · non incluse

ASAS DE PORTA EXTERIOR · PULL HANDLES · TIRADOR DE PUERTA · POIGNÉE DE PORTE

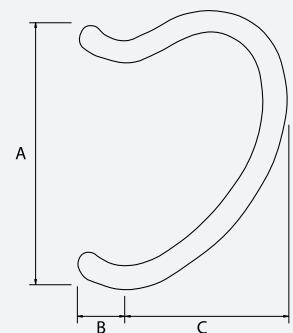
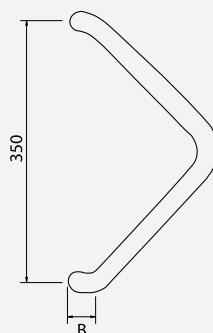
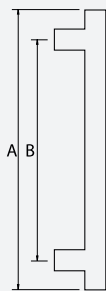

	Ø25	Ø30	Ø35	A	B
ASA	21310	-	-	300	200
	21320	-	-	350	250
	21330	21630	-	400	250
	21340	21640	21940	500	350
	21350	21650	21950	1000	850
PAR	21260	-	-	300	200
	21270	-	-	350	250
	21280	21580	-	400	250
	21290	21590	21890	500	350
	21300	21600	21900	1000	850

	Ø25	Ø30	Ø35	A	B
ASA	20210	20510	20810	350	Ø25 - 75
PAR	20200	20500	20800	350	Ø30 - 85
					Ø35 - 85

	Ø25	Ø30	Ø35	A	B	C
ASA	20240	20540	-	300	Ø25 - 75	220
	20250	20550	20840	350	Ø30 - 85	250
	-	-	20850	400	Ø35 - 85	250
PAR	20220	20520	-	300		
	20230	20530	20820	350		
	-	-	20830	400		



ASA "W"



ASA "U"

EMBALAGEM - PACKAGING
EMPAQUETADO - EMBALLAGE

1 unidade por caixa
1 piece per box
1 unidade por caja
1 piece par boîte

MATERIAIS - MATERIALS
MATERIALES - MATERIAUX

Inox (304)
Stainless steel (304)
Acero inox (304)
Inox (304)

NORMA - STANDARD
NORMA - NORME

EN 1670

OBSERVAÇÕES - COMMENTS
OBSERVACIONES - OBSERVATIONS

Kit aplicação simples - não incluído · not included · no incluido · non incluse
Kit aplicação dupla - não incluído · not included · no incluido · non incluse

ASAS DE PORTA EXTERIOR
PULL HANDLES
TIRADOR DE PUERTA
POIGNÉE DE PORTE

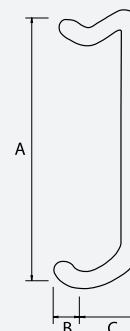

	Ø25	Ø30	Ø35	A	B	C
ASA	20310	20610	20910	300	Ø25 - 75	125
	20320	20620	20920	350	Ø30 - 85	150
	20330	20630	20930	400	Ø35 - 85	150
	20340	20640	20940	500		
	20350	20650	20950	1000		
PAR	20260	20560	20860	300		
	20270	20570	20870	350		
	20280	20580	20880	400		
	20290	20590	20890	500		
	20300	20600	20900	1000		

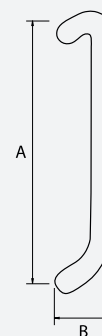

	Ø25	Ø30	Ø35	A	B
ASA	20150	20450	20750	300	Ø25 - 75
	20160	20460	20760	350	Ø30 - 85
	20170	20470	20770	400	Ø35 - 85
	20180	20480	20780	500	
	20190	20490	20790	1000	
PAR	20100	20400	20700	300	
	20110	20410	20710	350	
	20120	20420	20720	400	
	20130	20430	20730	500	
	20140	20440	20740	1000	



20097



20099



20010



20030

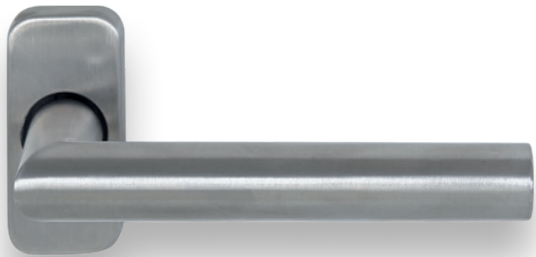

20070

EMBALAGEM - PACKAGING
EMPAQUETADO - EMBALLAGE

2 pares por caixa
2 pairs per box
2 pares por caja
2 paires par boîte

MATERIAIS - MATERIALS
MATERIALES - MATERIAUX

Inox (304)
Stainless steel (304)
Acero inox (304)
Inox (304)

FIXAÇÃO - FIXING
FIJACIÓN - FIXATION

Parafusos incluídos
Screws included
Tornillos incluidos
Vis inclus

NORMA - STANDARD
NORMA - NORME

EN 1670
EN 1906

OBSERVAÇÕES - COMMENTS
OBSERVACIONES - OBSERVATIONS

20097 / 20099
25 pares por caixa
25 pairs per box
25 pares por caja
25 paires par boîte

PUXADORES DE PORTA · DOOR HANDLES · MANILLA DE PUERTA · BÉQUILLE DE PORTE

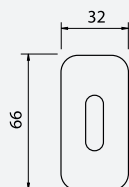
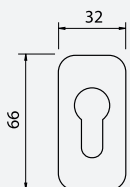
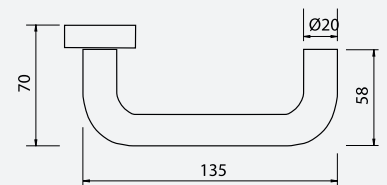
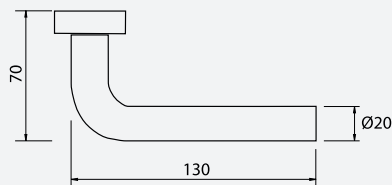
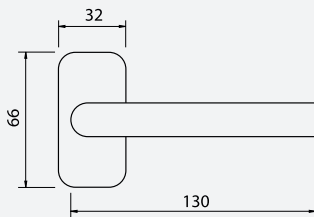

20000



20096

20020



20098

20060



EMBALAGEM - PACKAGING
EMPAQUETADO - EMBALLAGE

2 pares por caixa
2 pairs per box
2 pares por caja
2 paires par boîte

MATERIAIS - MATERIALS
MATERIALES - MATERIAUX

Inox (304)
Stainless steel (304)
Acero inox (304)
Inox (304)

FIXAÇÃO - FIXING
FIJACIÓN - FIXATION

Parafusos incluídos
Screws included
Tornillos incluidos
Vis inclus

NORMA - STANDARD
NORMA - NORME

EN 1670
EN 1906

OBSERVAÇÕES - COMENTS
OBSERVACIONES - OBSERVATIONS

20096 / 20098
25 pares por caixa
25 pairs per box
25 pares por caja
25 paires par boîte

PUXADORES DE PORTA · DOOR HANDLES · MANILLA DE PUERTA · BÉQUILLE DE PORTE

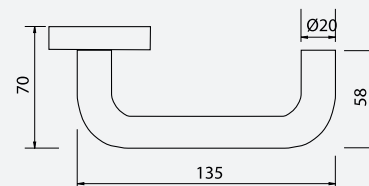
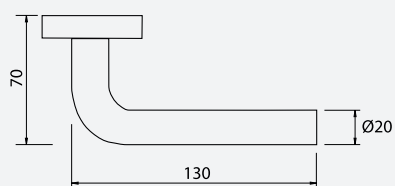
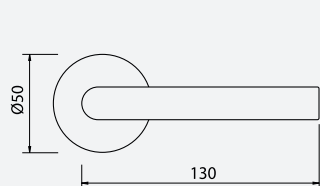

PUXADORES DE PORTA/JANELA
DOOR/WINDOW HANDLES
MANILLA DE PUERTA/VENTANA
BÉQUILLE DE PORTE/FENÊTRE

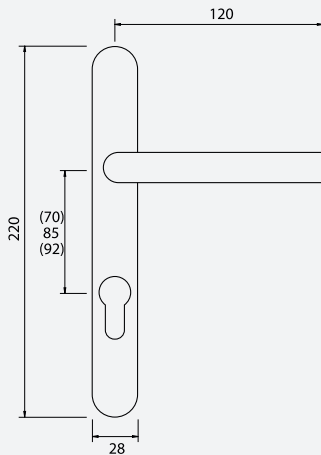

20090*

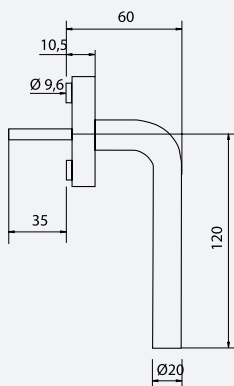
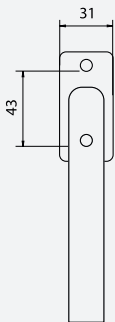

20040**



20090



20040

EMBALAGEM - PACKAGING
EMPAQUETADO - EMBALLAGE

6 pares por caixa
6 pairs per box
6 pares por caja
6 paires par boîte

NORMA - STANDARD
NORMA - NORME

EN 1670
EN 1906*
EN 13126**

MATERIAIS - MATERIALS
MATERIALES - MATERIAUX

Inox (304)
Stainless steel (304)
Acero inox (304)
Inox (304)

OBSERVAÇÕES - COMMENTS
OBSERVACIONES - OBSERVATIONS

20040
4 unidades por caixa
4 pieces per box
4 unidades por caja
4 pieces par boîte

FIXAÇÃO - FIXING
FIJACIÓN - FIXATION

Parafusos incluídos
Screws included
Tornillos incluidos
Vis inclus



4500



4600



4700



4800

EMBALAGEM - PACKAGING
EMPAQUETADO - EMBALLAGE

1 unidade por caixa
1 unit per box
1 unidade por caja
1 unité par boîte

MATERIAIS - MATERIALS
MATERIALES - MATERIAUX

Alumínio - Nylon
Alluminium - Nylon
Aluminio - Nylon
Alluminium - Nylon

ACABAMENTO - FINISHING
ACABADOS - FINITION

Lacado - Anodizado
Powder painting - Anodized
Lacado - Anodizado
Laqué - Anodisé

NORMA - STANDARD
NORMA - NORME

EN 1670

4500 / 4600

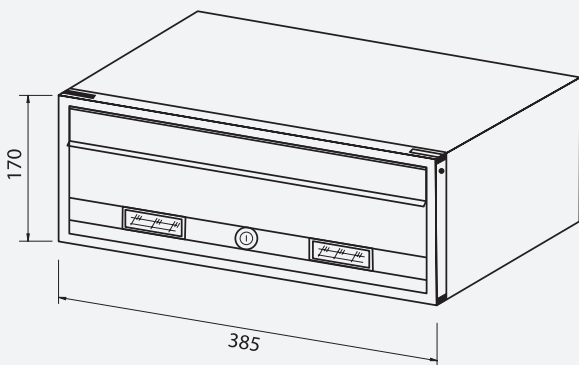

4700 / 4800

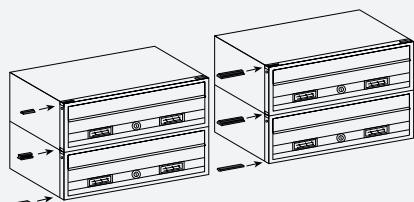
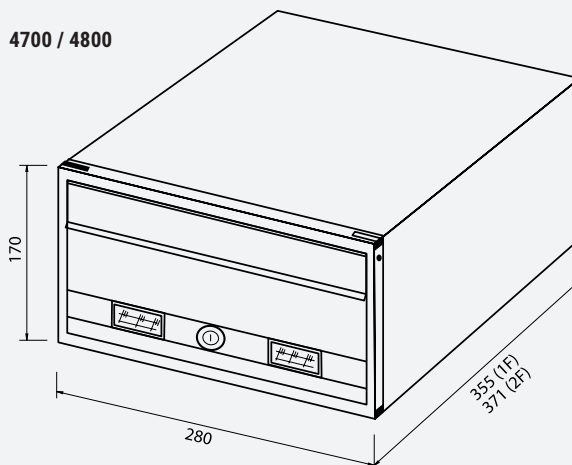

sistema de encaixe para módulos de várias unidades
fixation system for multiple modules
sistema de encaixe para módulos de varias unidades
systeme de fixation pour plusieurs modules

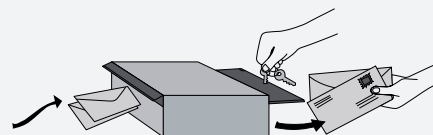

acesso posterior (4600 / 4800)
back access · acceso trazero · acce arriere

4400

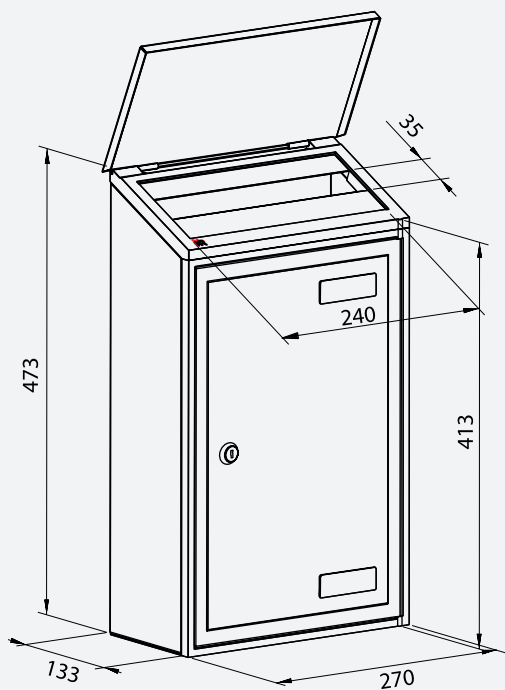

EMBALAGEM - PACKAGING
EMPAQUETADO - EMBALLAGE

1 unidade por caixa
1 unit per box
1 unidade por caja
1 unité par boîte

MATERIAIS - MATERIALS
MATERIALES - MATERIAUX

Alumínio - Inox
Alluminium - Stainless steel
Aluminio - Acero inox
Alluminium - Inox

NORMA - STANDARD
NORMA - NORME

EN 1670

ACABAMENTO - FINISHING
ACABADOS - FINITION

Lacado - Inox
Powder painting - Stainless steel
Lacado - Acero inox
Laqué - Inox



COMANDO MANIVELA



COMANDO ROLLY (C/ TRAVÃO)

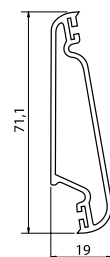
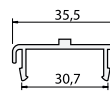
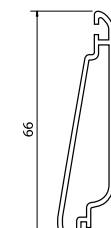
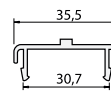
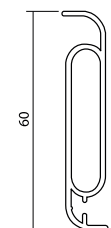
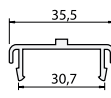
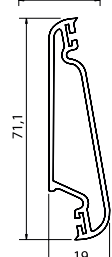
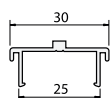
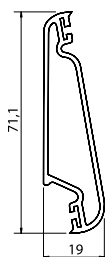
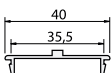
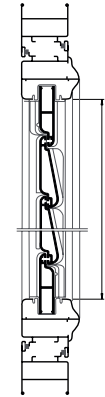
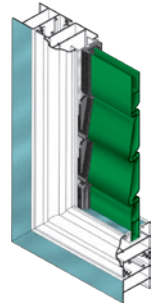
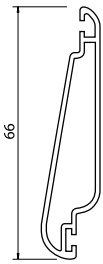
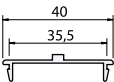
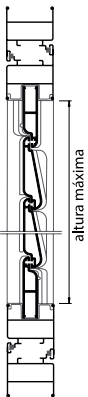
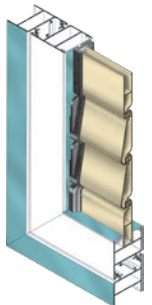
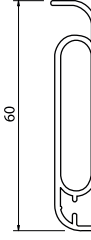
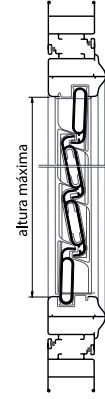
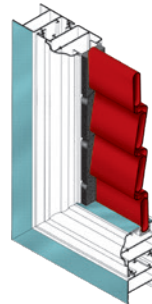
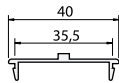
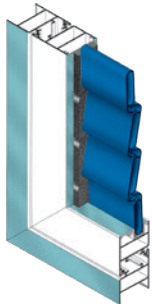

001



**SEGURA
PERSIANAS**

**EMBALAGEM - PACKAGING
EMPAQUETADO - EMBALLAGE**

100 unidades por caixa
100 pieces per box
100 unidades por caja
100 pieces par boîte

**MATERIAIS - MATERIALS
MATERIALES - MATERIAUX**

Nylon
Nylon
Nylon
Nylon

**ACABAMENTO - FINISHING
ACABADOS - FINITION**

Lacado - Anodizado
Powder painting - Anodized
Lacado - Anodizado
Laqué - Anodisé

**NORMA - STANDARD
NORMA - NORME**

EN 1670

**OBSERVAÇÕES - COMMENTS
OBSERVACIONES - OBSERVATIONS**

500
500 unidades por caixa
500 pieces per box
500 unidades por caja
500 pieces par boîte

SEGURA PERSIANAS
150 unidades por caixa
150 pieces per box
150 unidades por caja
150 pieces par boîte

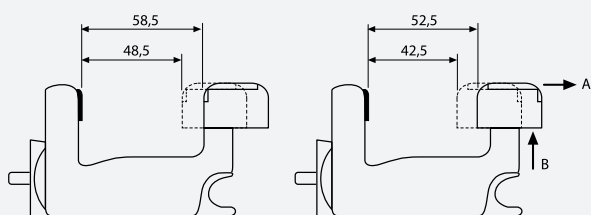

Para colocar a cabeça na cota que pretende:
A - Desloque a tampa no sentido da seta
B - Retire a cabeça

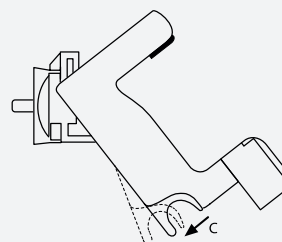

Para abrir:
C - Exerça pressão no sentido da seta



ASSA ABLOY





PUXADORES CORTA-FOGO

FIRESTOP DOOR HANDLES

MANILLAS PARA PUERTAS CORTA-FUEGO

POIGNÉE COUPE FEU



M1

M5

M3

CILINDRO NYLON

M8

EMBALAGEM - PACKAGING
EMPAQUETADO - EMBALLAGE

1 par por caixa
 1 pair per box
 1 par por caja
 1 pair par boîte

MATERIAIS - MATERIALS
MATERIALES - MATERIAUX

Aço - nylon
 Steel - nylon
 Acero - nylon
 Acier - nylon

FIXAÇÃO - FIXING
FIJACIÓN - FIXATION

Parafusos incluídos
 Screws included
 Tornillos incluidos
 Vis inclus

NORMA - STANDARD
NORMA - NORME

DO 20.17
 DIN 18 273 FS
 MPA NRW



MODELO
QUAD

M1

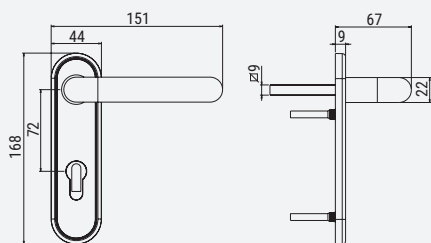

M5

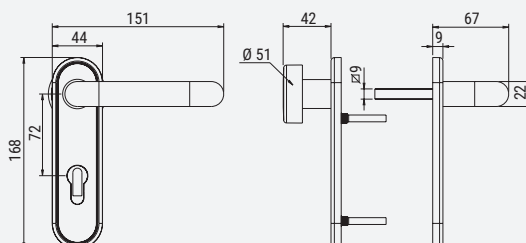

CILINDRO NYLON

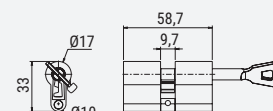

M3

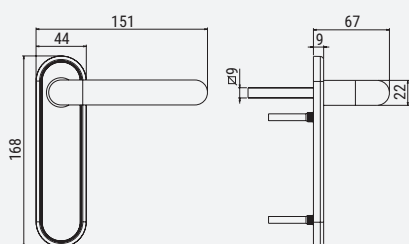

M8

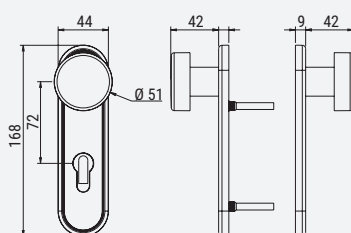

ACESSÓRIOS

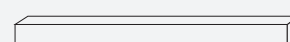

Veio
 9x120 mm



Cavilha
 5x100 mm



Perno
 5x9 mm





MULTIUSOS

☒ 8
 ☒ 9

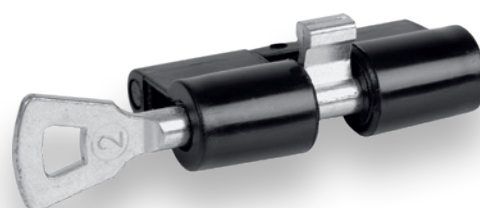

CILINDRO NYLON

EMBALAGEM - PACKAGING
EMPAQUETADO - EMBALLAGE

1 par por caixa
 1 pair per box
 1 par por caja
 1 pair par boîte

MATERIAIS - MATERIALS
MATERIALES - MATERIAUX

Nylon
 Nylon
 Nylon
 Nylon

FIXAÇÃO - FIXING
FIJACIÓN - FIXATION

Parafusos incluídos
 Screws included
 Tornillos incluidos
 Vis inclus

MULTIUSOS

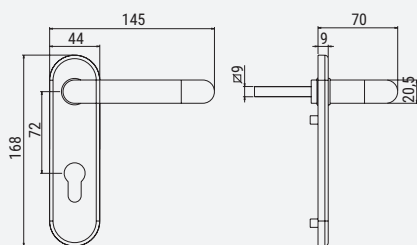

CILINDRO NYLON

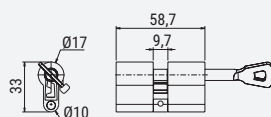

ACESSÓRIOS

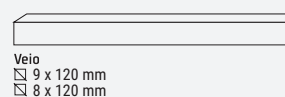

Veio
 ☒ 9 x 120 mm
 ☒ 8 x 120 mm



ASSA ABLOY





DIVERSOS MR

DIVERSE
DIVERSOS
DIVERS



www.mr.pt

SAPATA
cx. 100
PATER
cx. 200

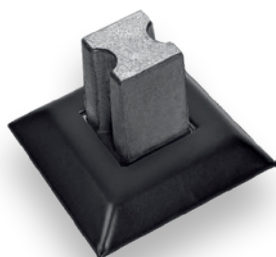

EIXO DESCENTRADO
cx. 300 un.



RESSALTO 6100
cx. 2 ct.



RESSALTO 9500
cx. 2 ct.



105
cx. 100

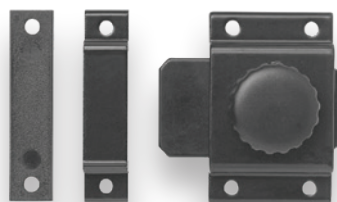

9010
ESPELHO OVAL
cx. 150 un.



9020
ESPELHO RECTANGULAR
cx. 150 un.



SNR
ESPELHO ALU
cx. 100 un.



SNR-QUAD
ESPELHO ALU
cx. 100 un.



Esquadros alinhamento



medida · dimension medida · mesure	un. p/ caixa · pieces per box un. p/ caja · pieces par boîte
24,7 x 5,3	120
14,47 x 5,3	120
10,7 x 5,3	120
Pino fixação	2000

PEÇA 504 MR
cx. 200 un.



PEÇA 506
cx. 200 un.



PEÇA 505
cx. 200 un.



PEÇA 504 CE SIMPLES
cx. 200 un.



PEÇA 504 CE DUPLA
cx. 200 un.



PONTEIRA 510 CE
cx. 200 un.



PONTEIRA 503 CE
cx. 200 un.



512
PONTEIRA EM ZAMAK
cx. 100 un.



CONJUNTO 104
cx. 150 conj.



PEÇA 134
cx. 200 un.



CONJUNTO 502

cx. 200 conj.



150

NIVELADOR VIDRO
(EXCÊNTRICO)

cx. 250 un.



R10

TAPA FUROS

cx. 15 ml.



100

CONCHA NYLON

cx. 150 un.



4340

CANTO ZAMAK

cx. 150 un.



140

NIVELADOR VIDRO

cx. 250 un.



160

TOPOS LÂMINA FIXA

cx. 2000 un.



000

BATENTES PVC

cx. 15 ml.



4340

CANTO NYLON

cx. 500 un.



24x16

ESQUADRO PRÉ-MARCO

cx. 300 un.

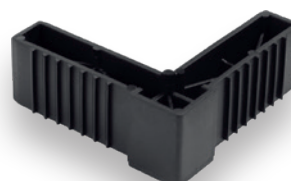

37x16
ESQUADRO PRÉ-MARCO
cx. 200 un.

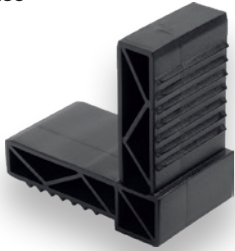

R32
TOPOS
cx. 1500 un.



R40
TOPOS
cx. 600 un.



R60
TOPOS
cx. 150 un.



120
CHAPA TESTA CE DUPLA
cx. 150 un.



130
CHAPA TESTA CE SIMPLES
cx. 150 un.





ASSA ABLOY





FECHADURAS

LOCKS

CERRADURAS

SERRURES

www.mr.pt

ASSA ABLOY



DIG. 1	DIG. 2	DIG. 3	DIG. 4	DIG. 5	DIG. 6
Categoria de utilização Category of use Catégorie d'utilisation Einsatzbereich	Durabilidade Durability Durabilité Dauerfunktion	Massa da porta e força de fecho Door mass and closing force Masse de la porte et force de fermeture Türgewicht und Schliesskraft	Resistência ao fogo Fire resistance Resistance au feu Feuerschutz	Segurança de pessoas Safety Sécurité des personnes Personenschutz	Resistência à corrosão e a temperatura Corrosion and temperature resistance Résistance à la corrosion et température Korrosionsschutz
1-3	A, B, C, F, G, H, L, M, R, S, W, X	1-9	0, 1	0	0, A-G

Class 1

- utilização por pessoas muito cuidadas e onde há uma baixa probabilidade de má utilização, por exemplo, portas de residências
- for use by people with a high incentive to exercise care and with a small chance of misuse, e.g. residential doors

Class 2

- utilização por pessoas cuidadas e onde há alguma probabilidade de má utilização, por exemplo, portas de escritórios
- for use by people with some incentive to exercise care but where there is some chance of misuse, e.g. office doors

Class 3

- utilização por público sem cuidado e onde há grande probabilidade de má utilização, por exemplo, portas de edifícios públicos
- for use by the public where there is little incentive to exercise care and where there is a high chance of misuse, e.g. doors in public buildings

A

- 50.000 ciclos de ensaio, sem carga no trinco
- 50.000 test cycles, no load on latch bolt

B

- 100.000 ciclos de ensaio, sem carga no trinco
- 100.000 test cycles, no load on latch bolt

C

- 200.000 ciclos de ensaio, sem carga no trinco
- 200.000 test cycles, no load on latch bolt

F

- 50.000 ciclos de ensaio, 10 N de carga no trinco
- 50.000 test cycles, 10 N load on latch bolt

G

- 100.000 ciclos de ensaio, 10 N de carga no trinco
- 100.000 test cycles, 10 N load on latch bolt

H

- 200.000 ciclos de ensaio, 10 N de carga no trinco
- 200.000 test cycles, 10 N load on latch bolt

L

- 100.000 ciclos de ensaio, 25 N de carga no trinco
- 100.000 test cycles, 25 N load on latch bolt

M

- 200.000 ciclos de ensaio, 25 N de carga no trinco
- 200.000 test cycles, 25 N load on latch bolt

R

- 100.000 ciclos de ensaio, 50 N de carga no trinco
- 100.000 test cycles, 50 N load on latch bolt

S

- 200.000 ciclos de ensaio, 50 N de carga no trinco
- 200.000 test cycles, 50 N load on latch bolt

W

- 100.000 ciclos de ensaio, 120 N de carga no trinco
- 100.000 test cycles, 120 N load on latch bolt

X

- 200.000 ciclos de ensaio, 120 N de carga no trinco
- 200.000 test cycles, 120 N load on latch bolt

1

- porta até 100 kg, força max. de 50 N para fechar
- up to 100kg door measure, 50 N maximum closing force

2

- porta até 200 kg, força max. de 50 N para fechar
- up to 200kg door measure, 50 N maximum closing force

3

- porta acima de 200 kg, força max. de 50 N para fechar
- above 200kg door measure, 50 N maximum closing force

4

- porta até 100 kg, força max. de 25 N para fechar
- up to 100kg door measure, 25 N maximum closing force

5

- porta até 200 kg, força max. de 25 N para fechar
- up to 200kg door measure, 25 N maximum closing force

6

- porta acima de 200 kg, força max. de 25 N para fechar
- above 200kg door measure, 25 N maximum closing force

7

- porta até 100 kg, força max. de 15 N para fechar
- up to 100kg door measure, 15 N maximum closing force

8

- porta até 200 kg, força max. de 15 N para fechar
- up to 200kg door measure, 15 N maximum closing force

9

- porta acima de 200 kg, força max. de 15 N para fechar
- above 200kg door measure, 15 N maximum closing force

0

- Não aptas a serem utilizadas em blocos-porta de compartimentação de fogo/fumo
- not approved for use on fire/smoke resisting door assemblies

1

- Aptas para utilização em blocos-porta de compartimentação de fogo/fumo, submetida a uma avaliação satisfatória da contribuição da fechadura à resistência ao fogo de blocos-porta de compartimentação de fogo/fumo especificada. Tal comprovação está fora do âmbito desta norma Europeia
- suitable for use on fire/smoke resisting door assemblies, subject to satisfactory assessment of the contribution of the lock or latch to the fire resistance of specified fire/smoke resisting door assemblies. Such assessment is beyond the scope of this European Standard

0

- nenhum requisito
- no safety requirements

0

- resistência à corrosão não definida, sem requisito de temperatura
- no defined corrosion resistance, no temperature requirement

A

- baixa resistência à corrosão, sem requisito de temperatura
- low corrosion resistance, no temperature requirement

B

- moderada resistência à corrosão, sem requisito de temperatura
- moderate corrosion resistance, no temperature requirement

C

- alta resistência à corrosão, sem requisito de temperatura
- high corrosion resistance, no temperature requirement

D

- muito alta resistência à corrosão, sem requisito de temperatura
- very high corrosion resistance, no temperature requirement

E

- moderada resistência à corrosão, requisito de temperatura: de -20°C a +80°C
- moderate corrosion resistance, temperature requirement: from -20 °C to +80 °C

F

- alta resistência à corrosão, requisito de temperatura: de -20°C a +80°C
- high corrosion resistance, temperature requirement: from -20 °C to +80 °C

G

- muito alta resistência à corrosão, requisito de temperatura: de -20°C a +80°C
- very high corrosion resistance, temperature requirement: from -20 °C to +80 °C



DIG. 7	DIG. 8	DIG. 9	DIG. 10	DIG. 11
<p>Segurança de bens e resist. à perfuração Security and drill resistance Sécurité des biens et résistance au percage Einbruchshemmung und Aufbohrschutz</p>	<p>Campo de aplicação na porta Fields of door application Domaine d'application de la porte Anwendungsbereich der Tür</p>	<p>Tipo de accionamento da chave e de bloqueio Type of key operation and locking Type de manoeuvre de clé et verrouillage Art der Schließung und Verriegelung</p>	<p>Tipo de accionamento da quadra Type of spindle operation Type de manoeuvre de la tige carrée Bewegung des Vierkanntstiftes</p>	<p>Identificação da chave Key identification Identification de la clé Schlüsselerkennung</p>
1-7	A-F, H, J-N, P, R, S, T	0, A-H	0-4	0, A-H

- 1** - mínima segurança de bens e sem resistência à perfuração
- minimum security and no drill resistance
- 2** - baixa segurança de bens e sem resistência à perfuração
- Low security and no drill resistance
- 3** - média segurança de bens e sem resistência à perfuração
- medium security and no drill resistance
- 4** - alta segurança de bens e sem resistência à perfuração
- high security and no drill resistance
- 5** - Alta segurança de bens e com resistência à pe
- high security with drill resistance
- 6** - muito alta segurança de bens e sem resistência à perfuração
- very high security and no drill resistance
- 7** - muito alta segurança de bens e com resistência à perfuração
- very high security with drill resistance

- A** - fechadura de embutir, aplicação não restringida
- mortice lock, unrestricted application
- B** - fechadura de embutir, porta com batente
- mortice lock, highed door
- C** - fechadura de embutir, porta deslizante
- mortice lock, sliding door
- D** - fechadura de sobrepor, aplicação não restringida
- rim lock, unrestricted application
- E** - fechadura de sobrepor, porta com batente
- rim lock, hinged door
- F** - fechadura de sobrepor, porta deslizante
- rim lock, sliding door
- H** - fechadura de embutir, porta com batente e apoio
- mortice lock, hinged door, supported
- J** - fechadura de sobrepor, porta com batente abertura só para interior
- rim lock, hinged door, inwards
- K** - fechadura de embutir, porta com batente, fecho interior
- mortice lock, hinged door, locked from inside
- L** - fechadura de embutir, porta deslizante, fecho interior
- mortice lock, sliding door, locked from inside
- M** - fechadura de sobrepor, porta com batente, fecho interior
- rim lock, hinged door, locked from inside
- N** - fechadura de sobrepor, porta deslizante, fecho interior
- rim lock, sliding door, locked from inside
- P** - fechadura de embutir, porta com batente e apoio, fecho interior
- mortice lock, hinged door, supported, locked from inside
- R** - fechadura de sobrepor, porta com batente abertura só para interior, fecho interior
- rim lock, hinged door, inwards, locked from inside
- S** - fechadura de embutir, sem limite aplicação, fecho interior
- mortice lock, unrestricted application, locked from inside
- T** - fechadura de sobrepor, sem limite aplicação, fecho interior
- rim lock, unrestricted application, locked from inside

- 0** - não aplicavel
- not applicable
- A** - fechadura de cilindro, bloqueio manual
- cylinder lock or latch, manually locking
- B** - fechadura de cilindro, bloqueio automático
- cylinder lock or latch, automatically locking
- C** - fechadura de cilindro, bloqueio manual com bloqueio intermédio
- cylinder lock or latch, manually locking with intermediate locking
- D** - fechadura de chave, bloqueio manual
- lever lock or latch, manually locking
- E** - fechadura de chave, bloqueio automático
- lever lock or latch, automatically locking
- F** - fechadura de chave, bloqueio manual com bloqueio intermédio
- lever lock or latch, manually locking with intermediate locking
- G** - fechadura sem chave, bloqueio manual
- lock or latch without key operation, manually locking
- H** - fechadura sem chave, bloqueio automático
- lock without key operation, automatically locking

- 0** - fechadura sem zarelho
- lock or latch without follower
- 1** - fechadura accionada por puxador redondo ou de muleta com mola de retorno
- lock or latch for knob or sprung lever handle operation
- 2** - fechadura accionada por puxador de muleta sem mola de retorno
- lock or latch for unsprung lever handle operation
- 3** - fechadura accionada por puxador de muleta sem mola de retorno, para utilização severa
- lock or latch for heavy duty unsprung lever handle operation
- 4** - fechadura accionada por puxador de muleta sem mola de retorno, para utilização severa especificada pelo produtor
- lock or latch for heavy duty unsprung lever handle operation specified by the manufacturer

- 0** - sem requisito
- no requirements
- A** - mínimo 3 caixetas
- minimum three detaining elements
- B** - mínimo 5 caixetas
- minimum five detaining elements
- C** - mínimo 5 caixetas, com numero alargado de combinações efectivas
- minimum five detaining elements, extended number of effective differs
- D** - mínimo 6 caixetas
- minimum six detaining elements
- E** - mínimo 6 caixetas, com numero alargado de combinações efectivas
- minimum six detaining elements, extended number of effective differs
- F** - mínimo 7 caixetas
- minimum seven detaining elements
- G** - mínimo 7 caixetas, com numero alargado de combinações efectivas
- minimum seven detaining elements, extended number of effective differs
- H** - mínimo 8 caixetas, com numero alargado de combinações efectivas
- minimum eight detaining elements, extended number of effective differs

USO DA FECHADURA

LOCK HANDING · VERROUILLAGE · LOCK USE

De acordo com a direção da porta, as fechaduras de embutir também são classificadas como fechaduras DIN esquerda e fechaduras DIN direita.

In accordance with the door directions, the mortise locks are also classified as DIN left hand and DIN right hand locks.

Conformément à la direction de la porte, les serrures à mortaiser sont également classées comme serrures DIN gauche et DIN droite.

Analog zur Anschlagsrichtung, gerade bei gefälzten Türen, werden Schlösser auch in DIN Rechts/ DIN Links unterschieden.

1 FECHADURA DIN ESQUERDA

DIN LEFT LOCK · SERRURE DIN GAUCHE · DIN LINKS SCHLOSS

O lado reto do trinco indica para a esquerda.

The straight side of the latch bolt points to the left.

Le côté droit du pêne ½ tour indique vers la gauche.

Der Fallenrücken ist bei Draufsicht links.

2 FECHADURA DIN DIREITA

DIN RIGHT LOCK · SERRURE DIN DROIT · DIN RECHTS SCHLOSS

O lado reto do trinco indica para a direita.

The straight side of the latch bolt points to the right.

Le côté droit du pêne ½ tour indique vers la droite.

Der Fallenrücken ist bei Draufsicht rechts.



DIREÇÃO DE ABERTURA · OPENING DIRECTION

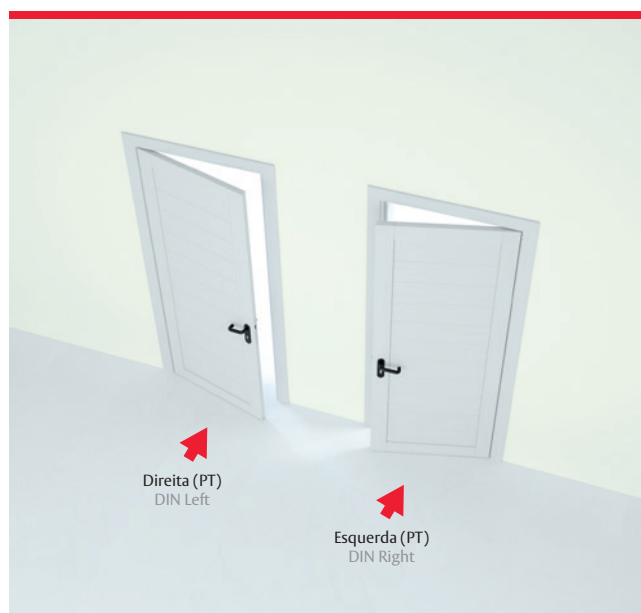

Chapatesta
Strike plate
Gâche
Schließbleche



Roletto
Roller
Roleau
Rolle



Gancho
Hook
Crochet
Haken

Testa
Front plate
Têtière
Stulpe

Trinco
Latch bolt
Pêne ouvrant
Falle

Língua
Dead bolt
Pêne dormant
Riegel

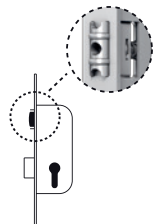
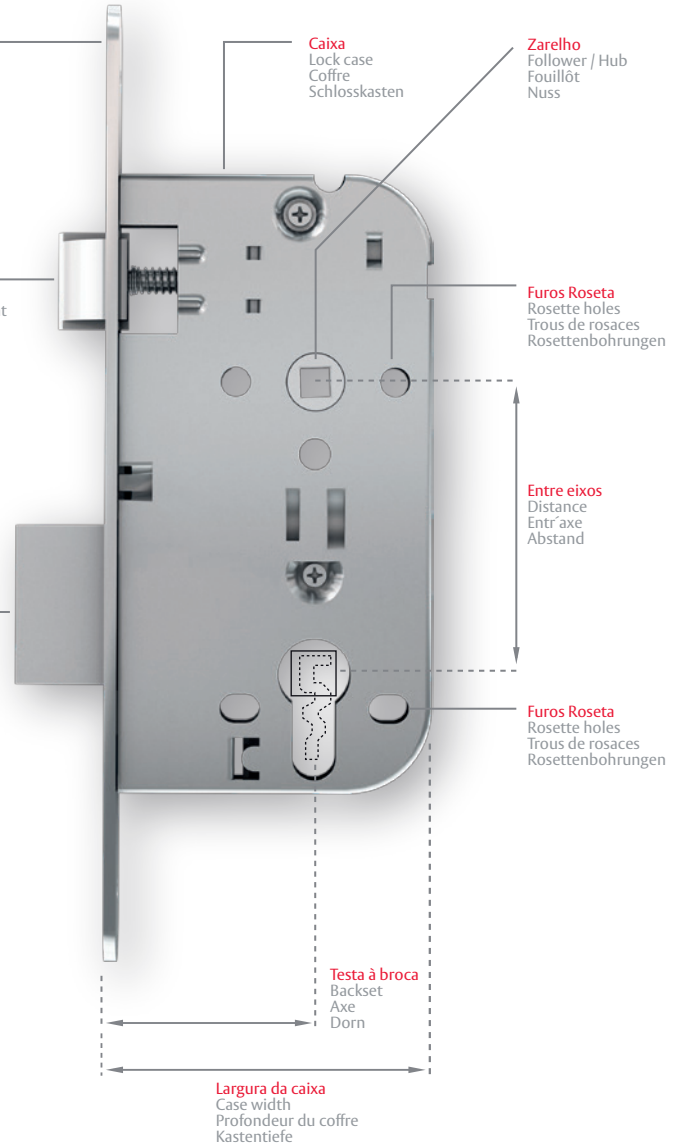

PT	CIL	IZ	ZC	CZ	H	SL.chv	SL.cil	R	G
EN	PC lock	Latch lock	WC lock	Key lock	Night Latch	Deadbolt lock	Deadbolt lock	Roller lock	Hook lock
FR	Clé-I	BdC	BdCC	Clé-L	Hotel	PdS-L	PdS-I	Rouleau	Mentonnet
DE	PZ-Schloss	Fallenschloss	WC-Schloss	BB-Schloss	PZ-Fallenschloss	Riegel-BB-Schloss	Riegel-PZ-Schloss	Rollenschloss	Hakenschloss

CONSELHOS DE UTILIZAÇÃO

ADVICES OF USE



Não furar a caixa da fechadura.

Do not drill through the lock case.



Não aplicar nem tinta nem verniz sobre o trinco ou língua da fechadura.

Do not paint latch and deadbolt.



Não use força para instalar o ferro quadrado do puxador na quadra.

Do not use force when installing the spindle.



O puxador deve ser apenas acionado no sentido normal de rotação. Uma força não superior a 150N pode ser aplicada no puxador no sentido de normal rotação. Utilizar apenas a chave apropriada (e não outros objetos estranhos).

Operate handle in the correct direction only. A maximum load of 150 N must not be exceeded by pushing down the handle. Only use the appropriate key (do not use any foreign body).



Não acionar simultaneamente o puxador e a chave.

Do not operate handle and key simultaneously.



Não fazer sair a língua da fechadura com a porta aberta.

To avoid any damage, deadbolt must not protrude when door is open.

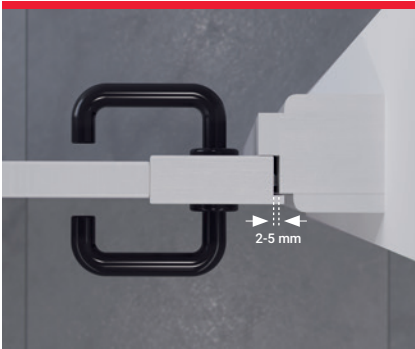

O espaço entre a testa e a chapa-testa deve ser de 2 a 5mm.
The clearance between face plate and strike plate must be 2-5 mm.



Não deixar a chave inserida numa fechadura antipânico.
Keys must not be left inserted in anti-panic locks.

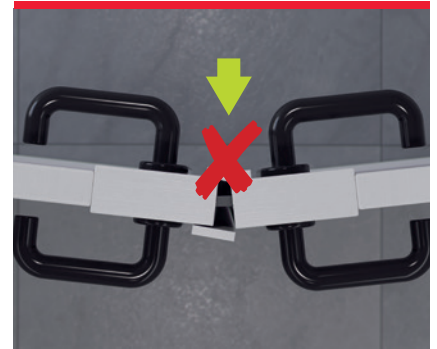

Não tentar abrir uma porta de 2 folhas destrancando a folha passiva enquanto a porta permanecer trancada.
French doors must not be forced open by unlocking the passive door while the active door remains locked.



Não usar o puxador para manusear a porta.
Do not use the handle furniture to carry the door.



A fechadura deve ser substituída assim que esta apresente algum dano ou deterioração.
The lock must be replaced as soon as it shows any damage.



Não usar cilindros que contenham um palhetão livre / móvel com fechaduras antipânico. Neste tipo de cilindros incluem-se por exemplo aqueles que possuem um palhetão que pode girar por eles mesmos sem a chave no interior ou também cilindros com botão.
Do not use cylinders comprising a free moving cam with anti-panic mortise locks. These types of cylinders include ones that possess a cam that can turn without an inserted key and thumb turn cylinders.

SÉRIE 727

Ftfa-727 / v.2

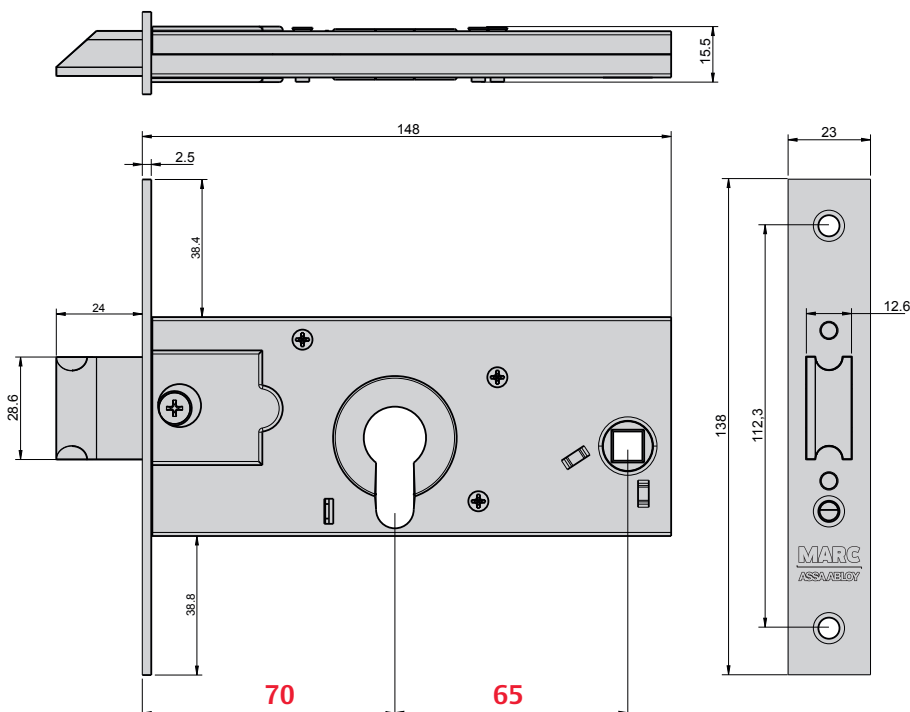

NORMA · STANDARD · NORME · NORM · EN12209



1 C 7 0 0 C 1 B A 2 0

Testes realizados no nosso laboratório de fábrica - Tests made in our factory lab
Testes réalisés en notre laboratoire d'usine - Im Marques-Labor geprüft und bestätigt

70	65	6,5 — 8

FTfa-732 / v.2

SÉRIE 732

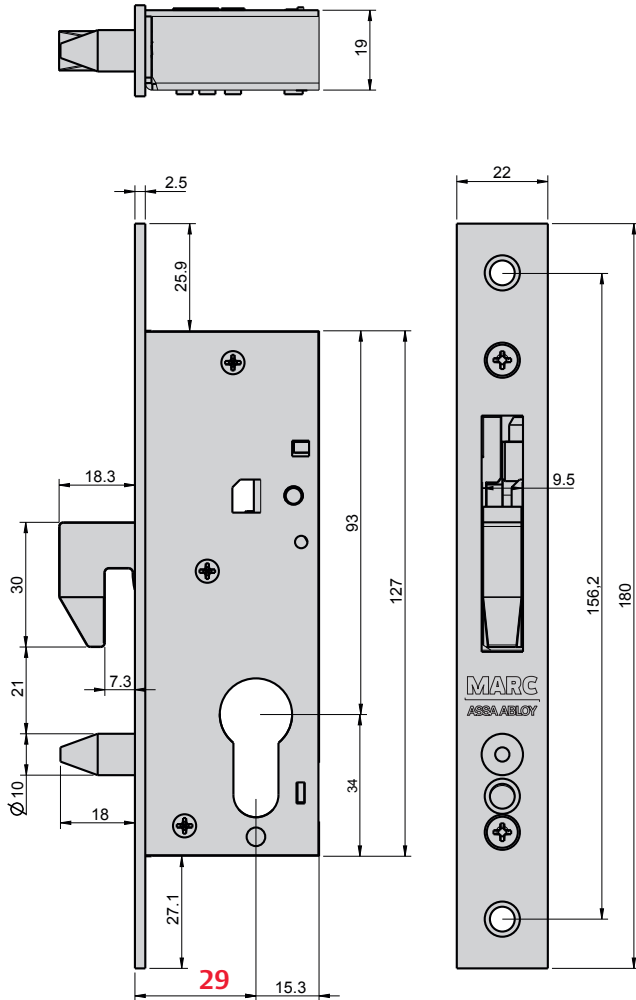

Opcional - Optional
Option - Optionen

NORMA · STANDARD · NORME · NORM · EN12209



Testes realizados no nosso laboratório de fábrica - Tests made in our factory lab
Testes réalisés en notre laboratoire d'usine - Im Marques-Labor geprüft und bestätigt

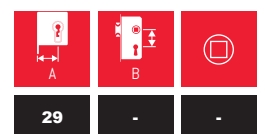

SÉRIE 731 LG

FTfa-731.LG / v.2

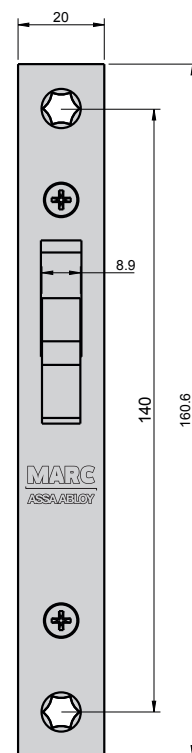
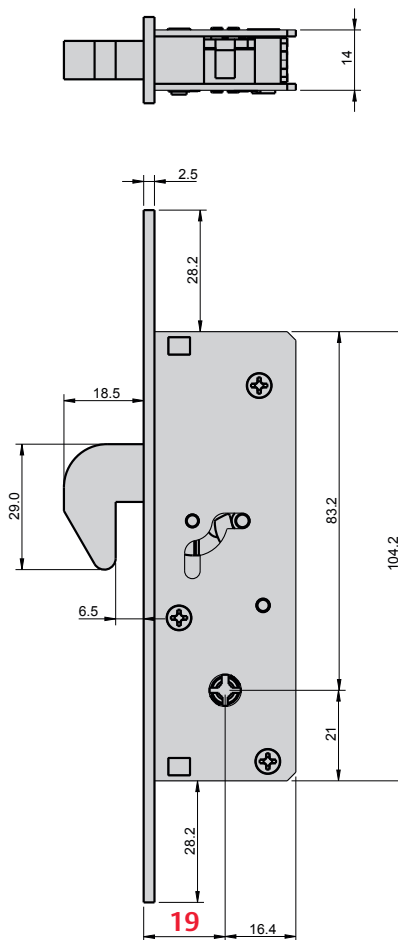

NORMA · STANDARD · NORME · NORM · EN12209



2 C - 0 0 C 1 B D 0 0

Testes realizados no nosso laboratório de fábrica · Tests made in our factory lab
Testes réalisés en notre laboratoire d'usine · Im Marques-Labor geprüft und bestätigt

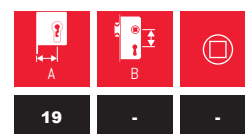

FTfa-731.LB / v.2

SÉRIE 731 LB

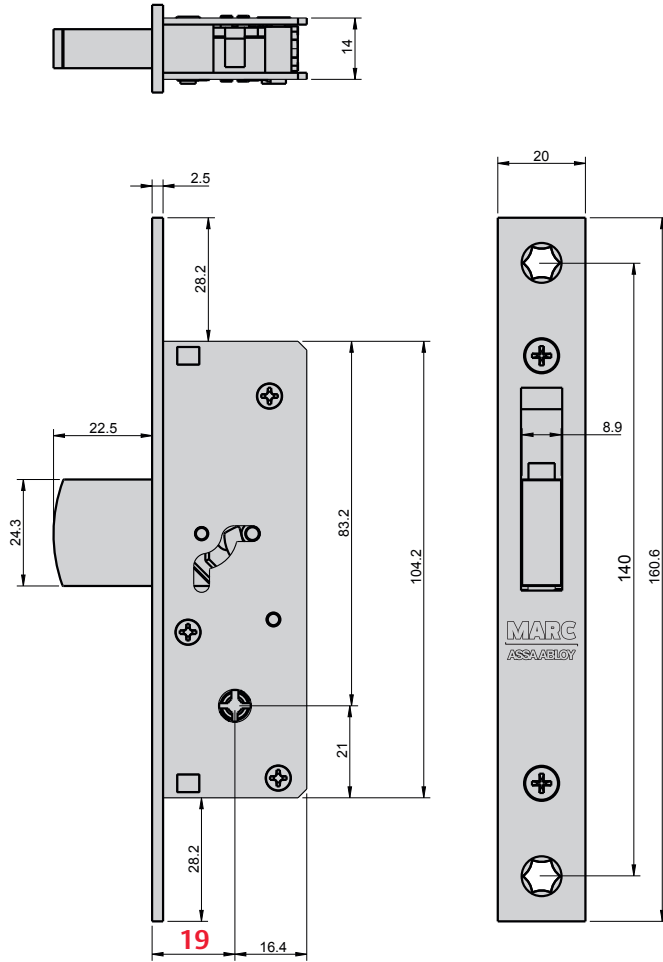

NORMA · STANDARD · NORME · NORM · EN12209



2 C - 0 0 C 1 B D 0 0

Testes realizados no nosso laboratório de fábrica - Tests made in our factory lab
Testes réalisés en notre laboratoire d'usine - Im Marques-Labor geprüft und bestätigt

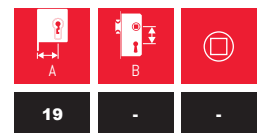

SÉRIE 728.70

FTfa-728.70 / v.2

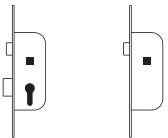
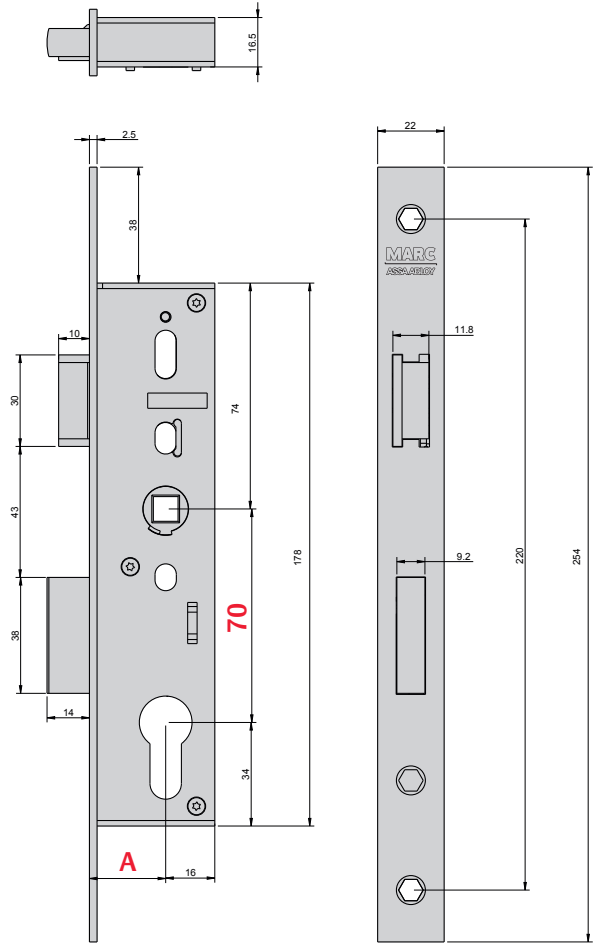

PT	LC (CL)	ST (1Z)
EN	PC lock	Latch lock
FR	Clé-I	BdC
DE	PZ-Schloss	Fallenschloss

NORMA · STANDARD · NORME · NORM · EN12209



2 M 7 0 0 C 2 B A 2 0

Testes realizados no nosso laboratório de fábrica - Tests made in our factory lab
Testes réalisés en notre laboratoire d'usine - Im Marques-Labor geprüft und bestätigt

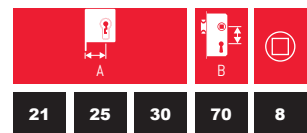

FTfa-528.85 / v.2

SÉRIE 528.85

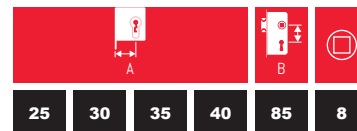
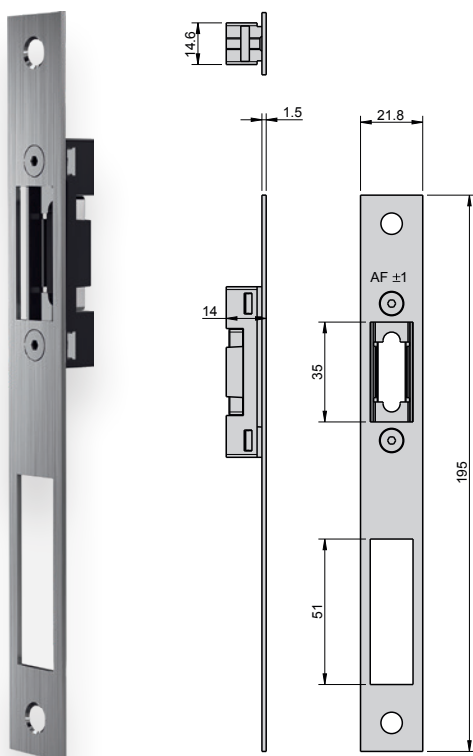
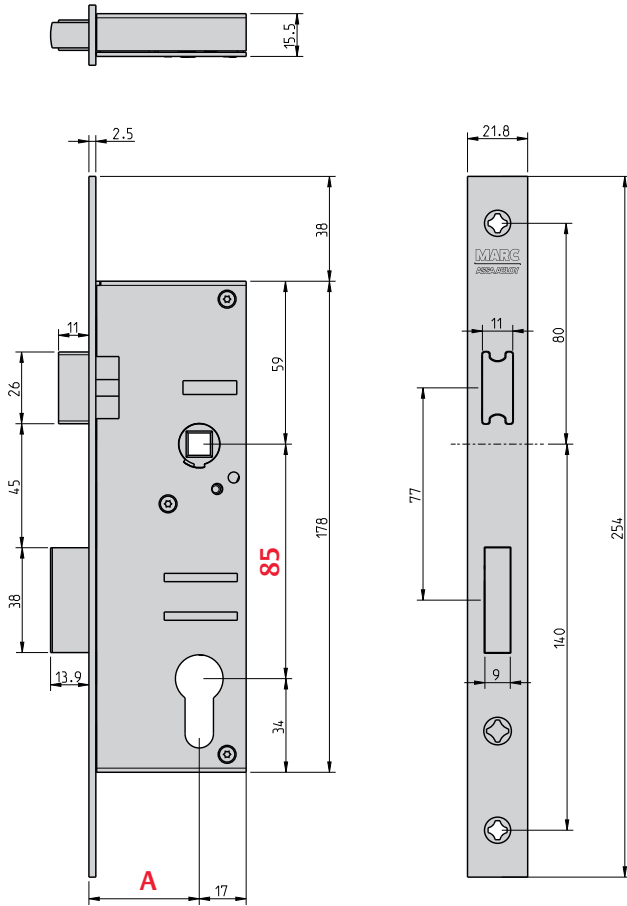

PT	CIL
EN	PC lock
FR	Clé-I
DE	PZ-Schloss

NORMA · STANDARD · NORME · NORM · EN12209



1 B 7 0 0 C 2 B A 2 0

Testes realizados no nosso laboratório de fábrica - Tests made in our factory lab
Testes réalisés en notre laboratoire d'usine - Im Marques-Labor geprüft und bestätigt

SÉRIE 728.85

FTfa-728.85 / v.2

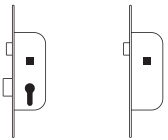
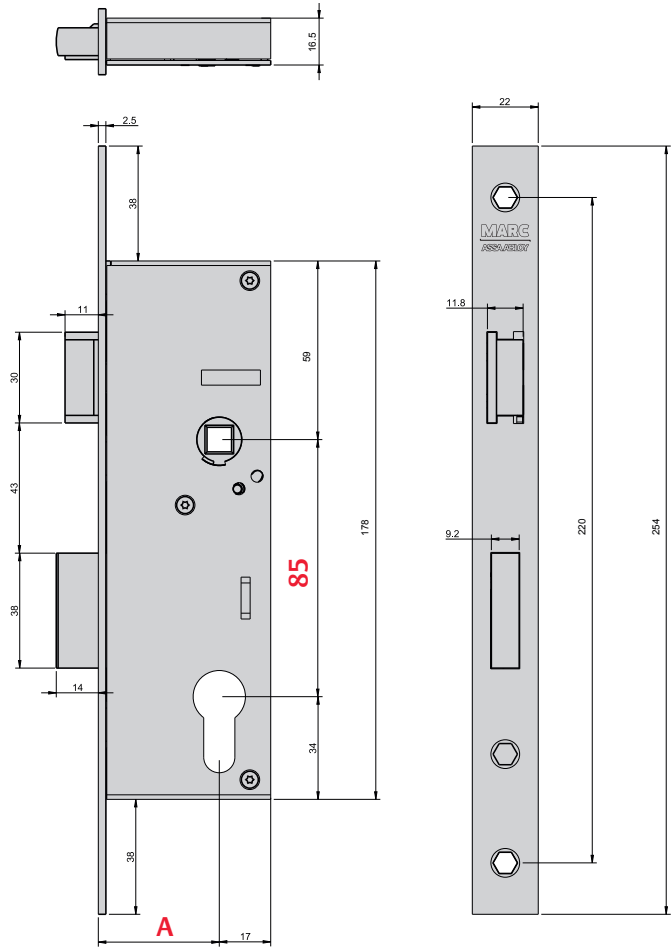

PT	LC (CIL)	ST (12)
EN	PC lock	Latch lock
FR	Clé-I	BdC
DE	PZ-Schloss	Fallenschloss

NORMA · STANDARD · NORME · NORM · EN12209



2 M 7 0 0 C 2 B A 2 0

Testes realizados no nosso laboratório de fábrica - Tests made in our factory lab
Testes réalisés en notre laboratoire d'usine - Im Marques-Labor geprüft und bestätigt

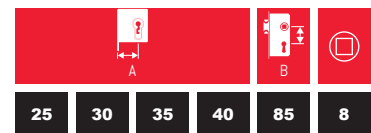

FTfa-528.92 / v.2

SÉRIE 528.92

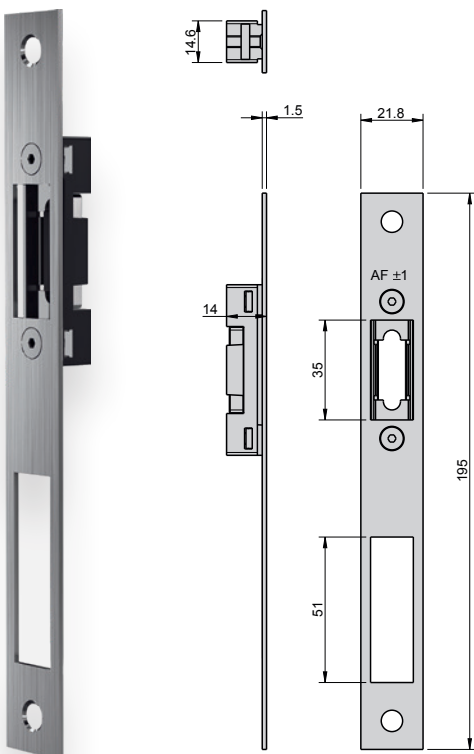
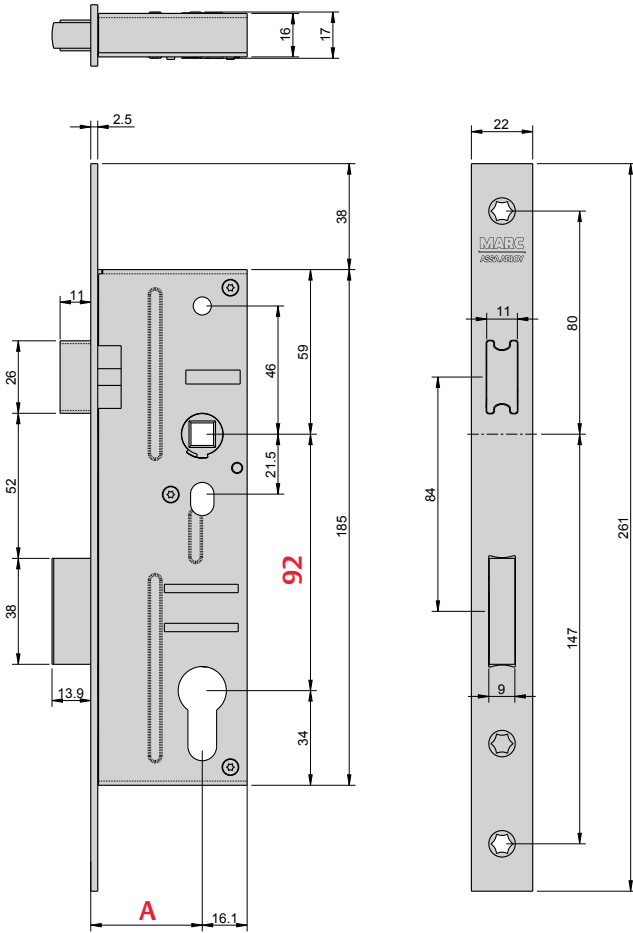

MAGNET

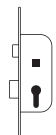
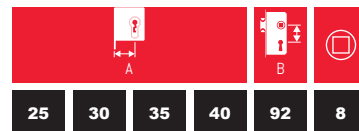

PT **CIL**
EN PClock
FR Clé-I
DE PZ-Schloss

NORMA · STANDARD · NORME · NORM · EN12209



1 B 7 0 0 C 2 B A 2 0

Testes realizados no nosso laboratório de fábrica · Tests made in our factory lab
Testes réalisés en notre laboratoire d'usine · Im Marques-Labor geprüft und bestätigt

SÉRIE 728.92

FTfa-728.92 / v.2

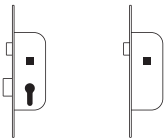
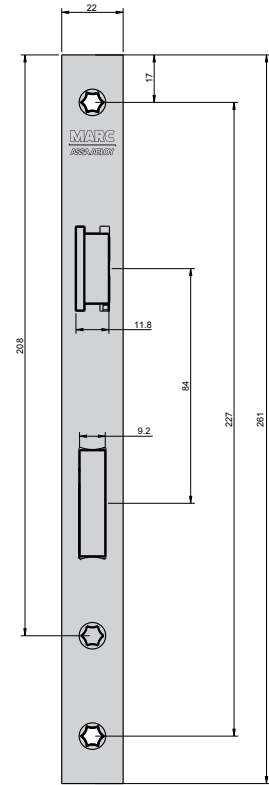
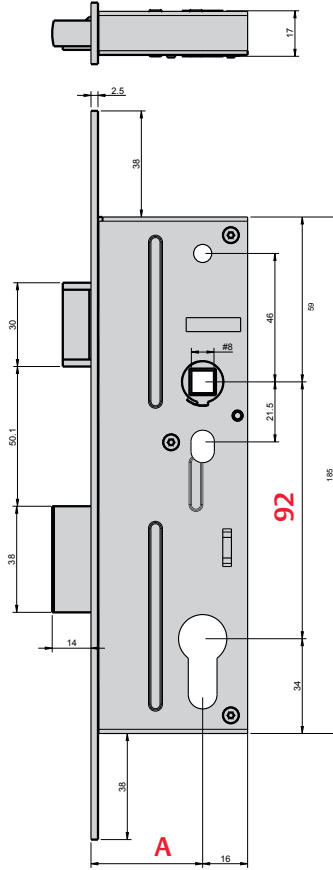

PT	LC (CIL)	ST (1Z)
EN	PC lock	Latch lock
FR	Clé-I	BdC
DE	PZ-Schloss	Fallenschloss

NORMA · STANDARD · NORME · NORM · EN12209



Testes realizados no nosso laboratório de fábrica - Tests made in our factory lab
Testes réalisés en notre laboratoire d'usine - Im Marques-Labor geprüft und bestätigt

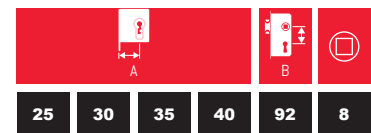

FTfa-728.AF.85 / v.2

SÉRIE 728.AF.85

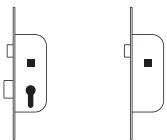
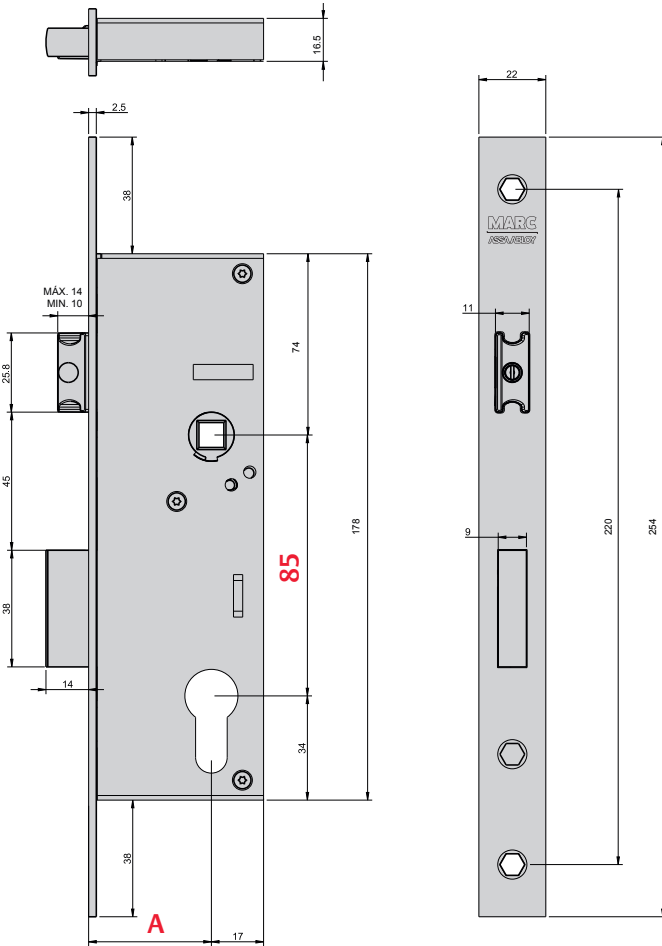

PT	LC (CIL)	ST (1Z)
EN	PC lock	Latch lock
FR	Clé-1	BdC
DE	PZ-Schloss	Fallenschloss

NORMA · STANDARD · NORME · NORM · EN12209



Testes realizados no nosso laboratório de fábrica - Tests made in our factory lab
Testes réalisés en notre laboratoire d'usine - Im Marques-Labor geprüft und bestätigt

30	35	40
85	8	

SÉRIE 728.AF.92

FTfa-728.AF.92 / v.2



Accessório - Accessory
Accessoire - Zubehör

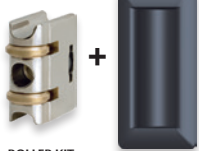

ROLLER KIT
Ref. R741

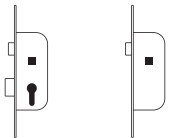
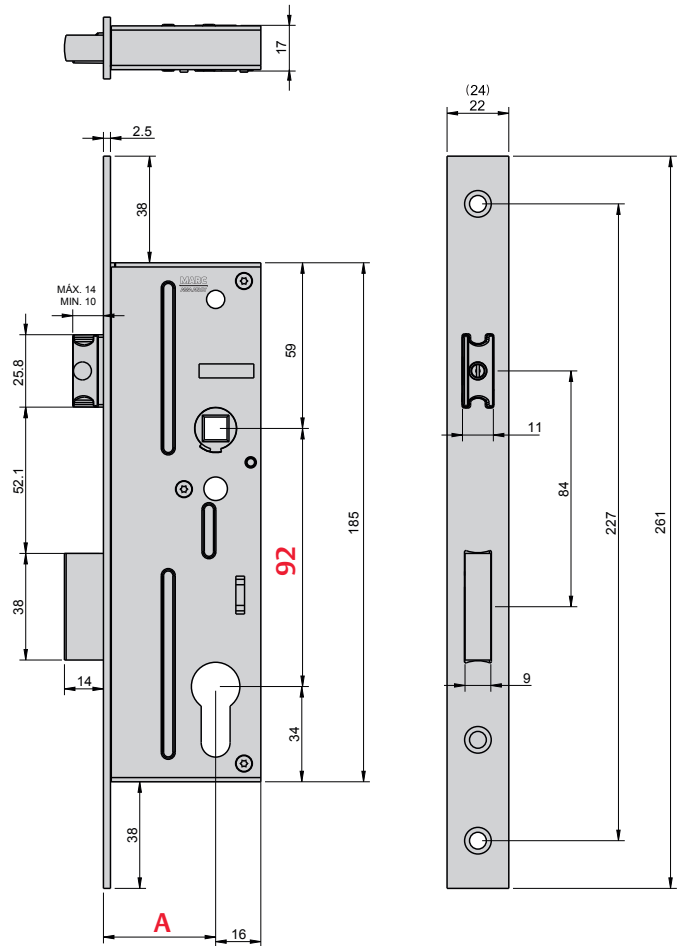

PT	LC (CIL)	ST (1Z)
EN	PC lock	Latch lock
FR	Clé-I	BdC
DE	PZ-Schloss	Fallenschloss

NORMA · STANDARD · NORME · NORM · EN12209



2 M 7 0 0 C 2 B A 2 0

Testes realizados no nosso laboratório de fábrica - Tests made in our factory lab
Testes réalisés en notre laboratoire d'usine - Im Marques-Labor geprüft und bestätigt

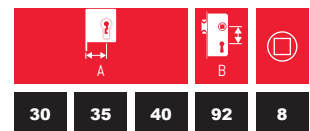

FTfa-730.85 / v.2

SÉRIE 730.85

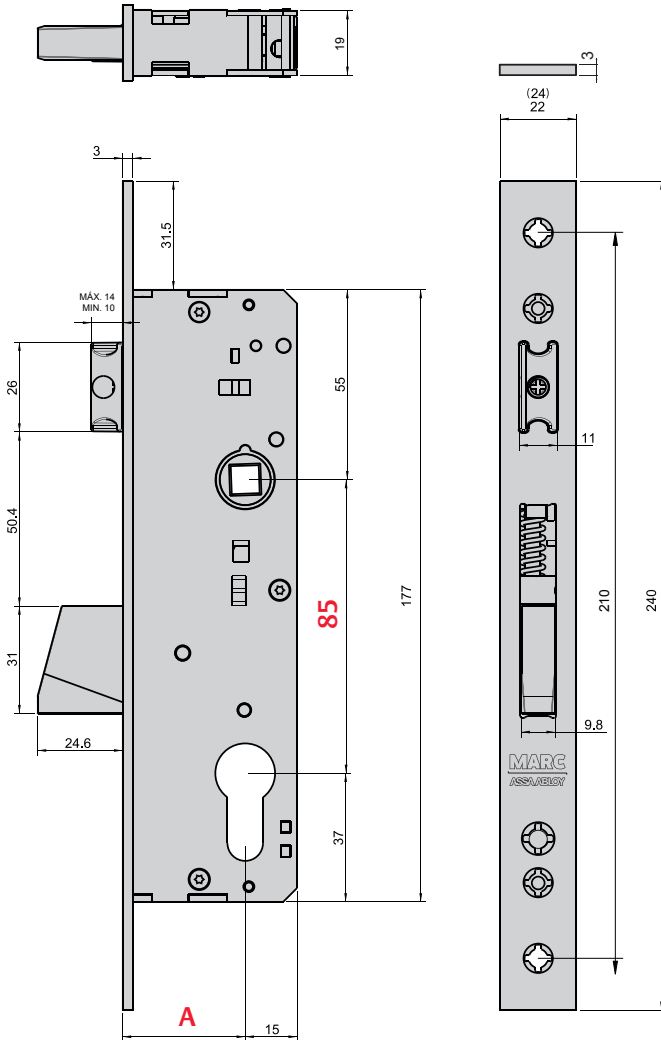

Opcional - Optional
Option - Optionen



Accesório - Accessory
Accessoire - Zubehör

PT LB	LG	SG	CIL (KABA)
EN LB	LG	SG	KABA lock
FR LB	LG	SG	Clé-I KABA
DE LB	LG	SG	KABA-Schloss

NORMA · STANDARD · NORME · NORM · EN12209



Testes realizados no nosso laboratório de fábrica - Tests made in our factory lab
Testes réalisés en notre laboratoire d'usine - Im Marques-Labor geprüft und bestätigt

LB	25	30	35
		85	8
KABA	-	30	-
		87	8

SÉRIE 741

FTfa-741 / v.2



Accessório - Accessory
Accessoire - Zubehör

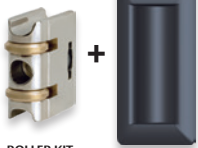

ROLLER KIT
Ref. R741

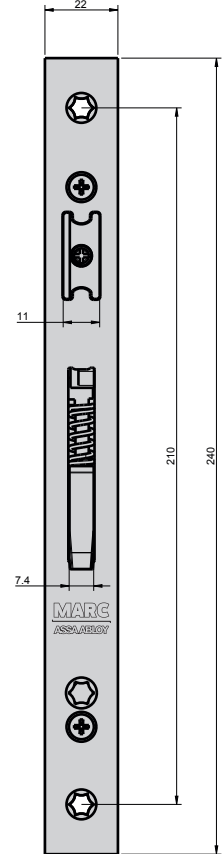
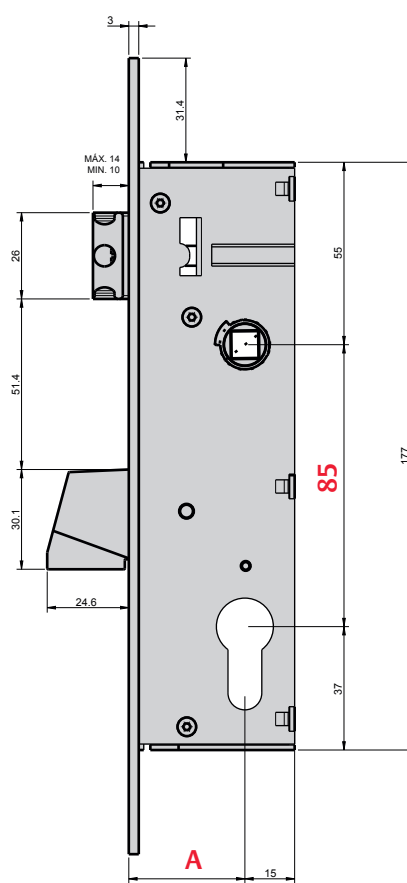
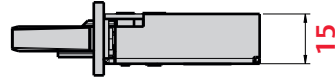

PT LB
EN LB
FR LB
DE LB

NORMA · STANDARD · NORME · NORM · EN12209



Testes realizados no nosso laboratório de fábrica - Tests made in our factory lab
Testes réalisés en notre laboratoire d'usine - Im Marques-Labor geprüft und bestätigt



FTfa-730.92 / v.2

SÉRIE 730.92

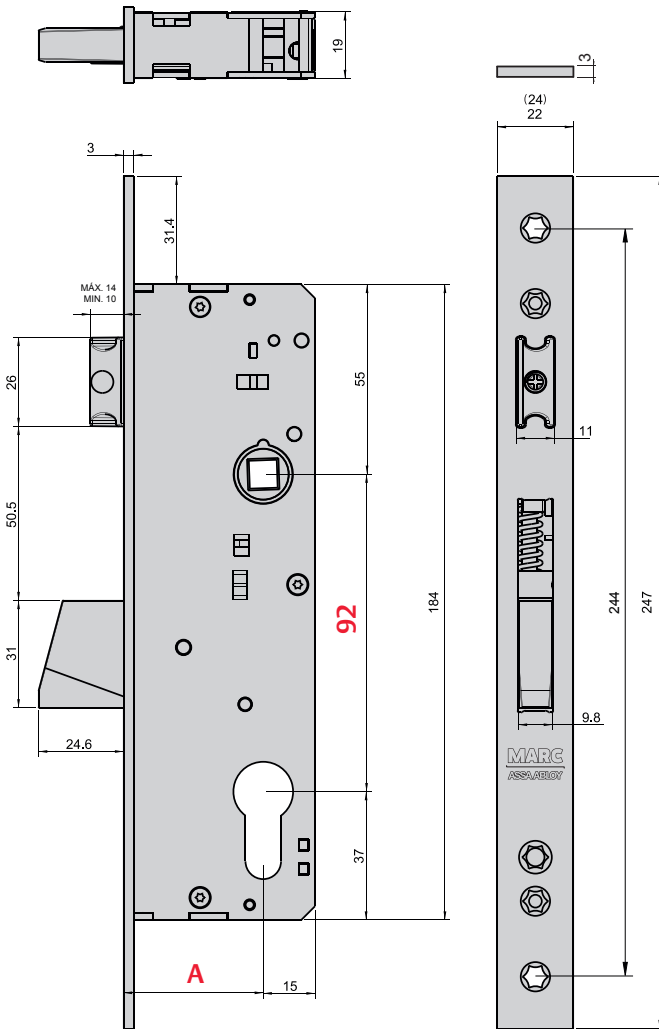

Optional - Optional
Option - Optionen



Acessório - Accessory
Accessoire - Zubehör



+



ROLLER KIT
Ref. R730

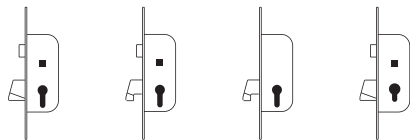

PT	LB	LG	SG	CIL (KABA)
EN	LB	LG	SG	KABA lock
FR	LB	LG	SG	Clé-1 KABA
DE	LB	LG	SG	KABA-Schloss

NORMA · STANDARD · NORME · NORM · EN12209



Testes realizados no nosso laboratório de fábrica - Tests made in our factory lab
Testes réalisés en notre laboratoire d'usine - Im Marques-Labor geprüft und bestätigt

	A				B	
LB	25	30	35	40	92	8
KABA	25	30	35	-	94	8

SÉRIE 430

FTfa-430 / v.2



ANTIPANIC*

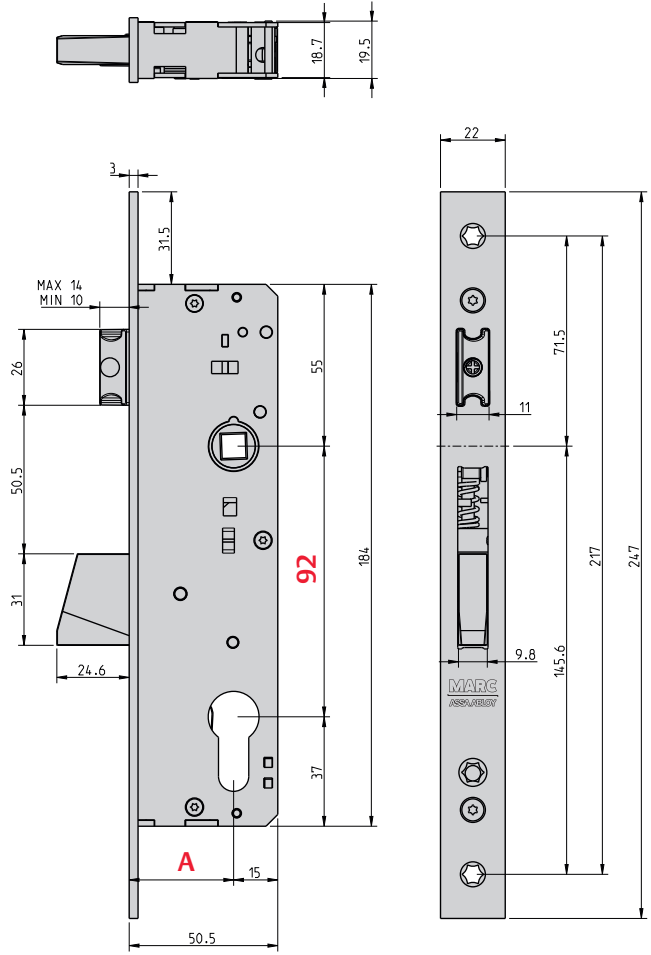

PT **CIL**
EN PC lock
FR Clé-I
DE PZ-Schloss

PT Perfil oval **UK** Oval-shaped profile
FR Profil ovale **DE** Ovaies Profil

NORMA · STANDARD · NORME · NORM · EN12209

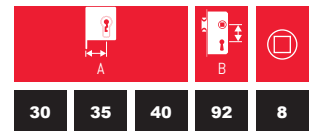

Testes realizados no nosso laboratório de fábrica - Tests made in our factory lab
Testes réalisés en notre laboratoire d'usine - Im Marques-Labor geprüft und bestätigt

* Fechadura com função antipânico tipo E sem certificação - * Lock with panic function type E without certification
* Serrure avec fonction anti-panique type E sans certification - * Schloss mit Panikfunktion Typ E ohne Zertifizierung

FTfa-730.DC / v.2

SÉRIE 730.DC

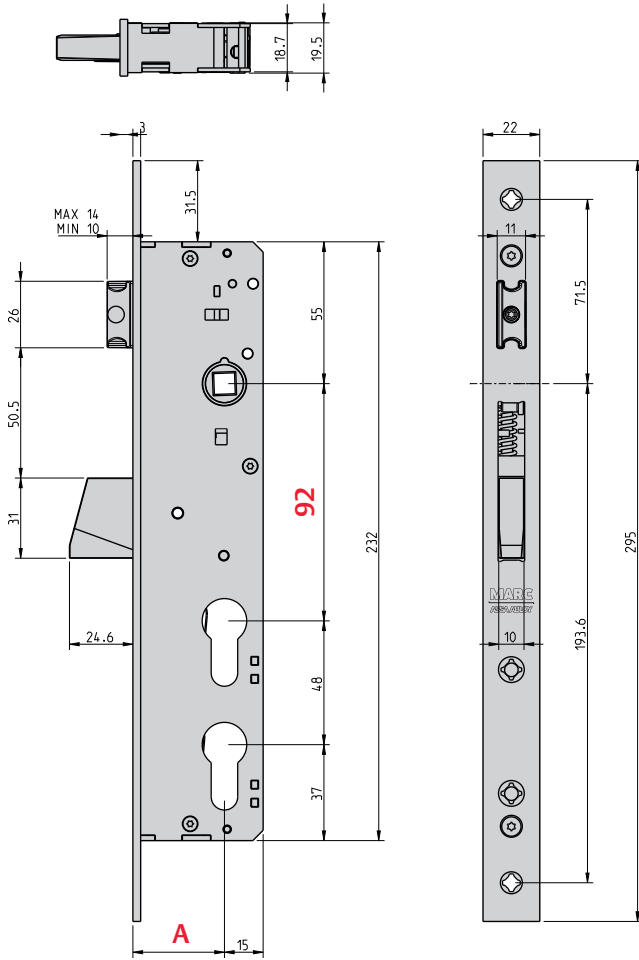

TANDEM



PT **CIL**
EN PC lock
FR Clé-I
DE PZ-Schloss

NORMA · STANDARD · NORME · NORM · EN12209



3 M 7 0 0 C 2 B A 3 0

Testes realizados no nosso laboratório de fábrica - Tests made in our factory lab
Testes réalisés en notre laboratoire d'usine - Im Marques-Labor geprüft und bestätigt

30	35	40
92	8	

SÉRIE 733

FTfa-733 / v.2



ELECTRIC
 | 12V
12VA

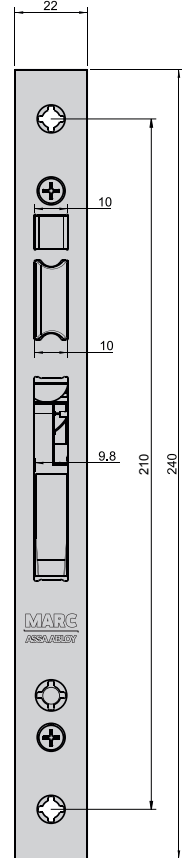
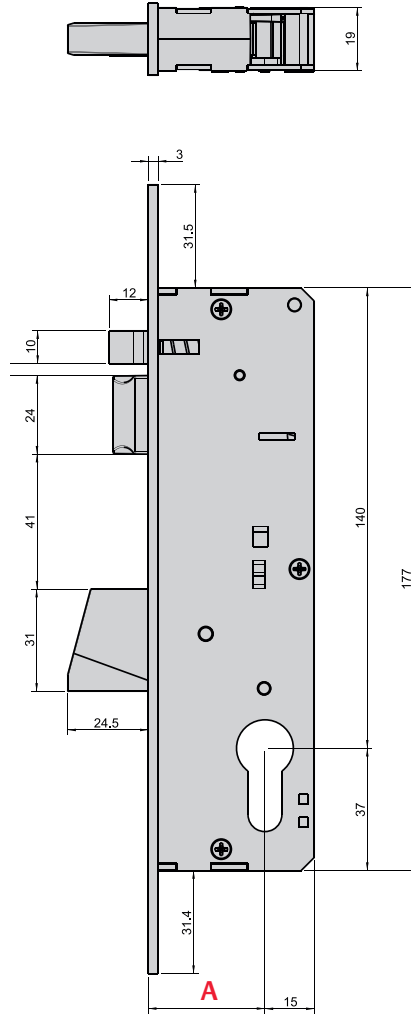

PT **LB**
 EN LB
 FR LB
 DE LB

NORMA · STANDARD · NORME · NORM · EN12209



3 C 7 0 0 C 2 B A 0 0

Testes realizados no nosso laboratório de fábrica - Tests made in our factory lab
 Testes réalisés en notre laboratoire d'usine - Im Marques-Labor geprüft und bestätigt



FTfa-ZKX35 / v.2

SÉRIE ZKX35 (40)

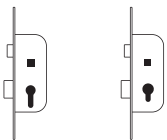
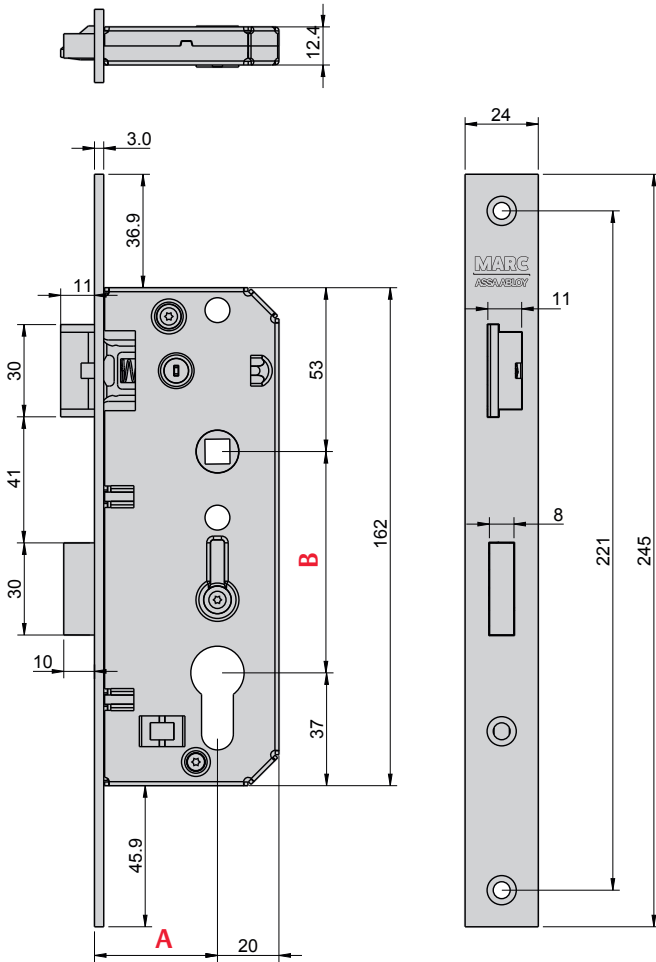

PT	CIL	CIL (KABA)
EN	PC lock	KABA lock
FR	Clé-1	Clé-1 KABA
DE	PZ-Schloss	KABA-Schloss

NORMA · STANDARD · NORME · NORM · EN12209



2 C 7 0 0 C 2 H A 2 0

Testes realizados no nosso laboratório de fábrica - Tests made in our factory lab
Testes réalisés en notre laboratoire d'usine - Im Marques-Labor geprüft und bestätigt

PZ	35	72	8
PZ	40		
KABA	35	74	
KABA	40		

SÉRIE 781

FTfa-781 / v.2

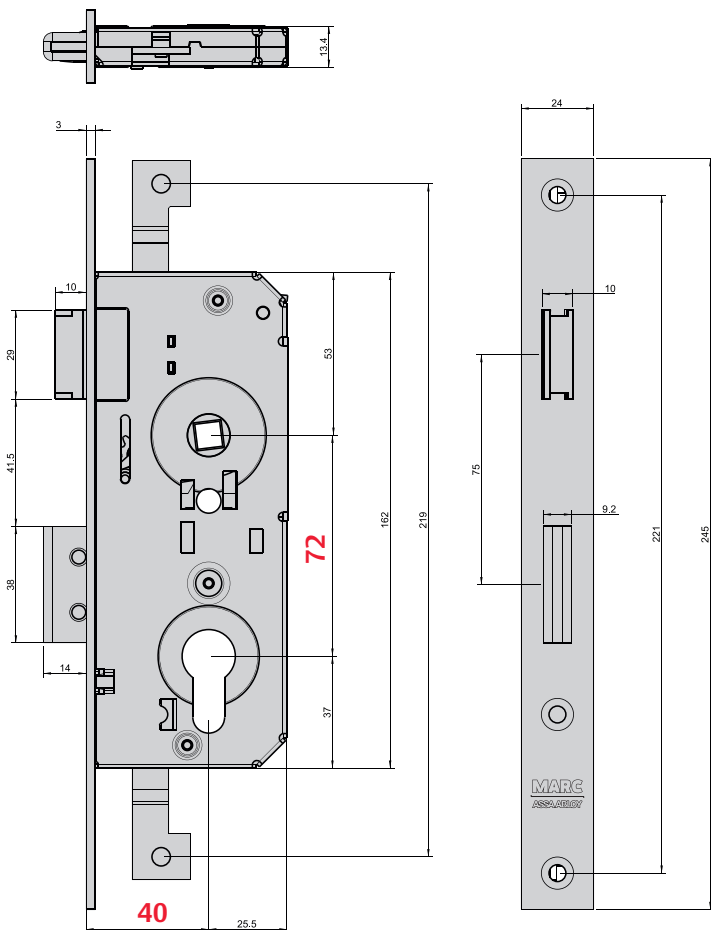

NORMA · STANDARD · NORME · NORM · EN12209



3 C 7 0 0 C 2 H A 2 0

Testes realizados no nosso laboratório de fábrica · Tests made in our factory lab
Testes réalisés en notre laboratoire d'usine · Im Marques-Labor geprüft und bestätigt

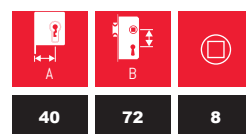

FTfa-745.U / v.2

SÉRIE 745-U

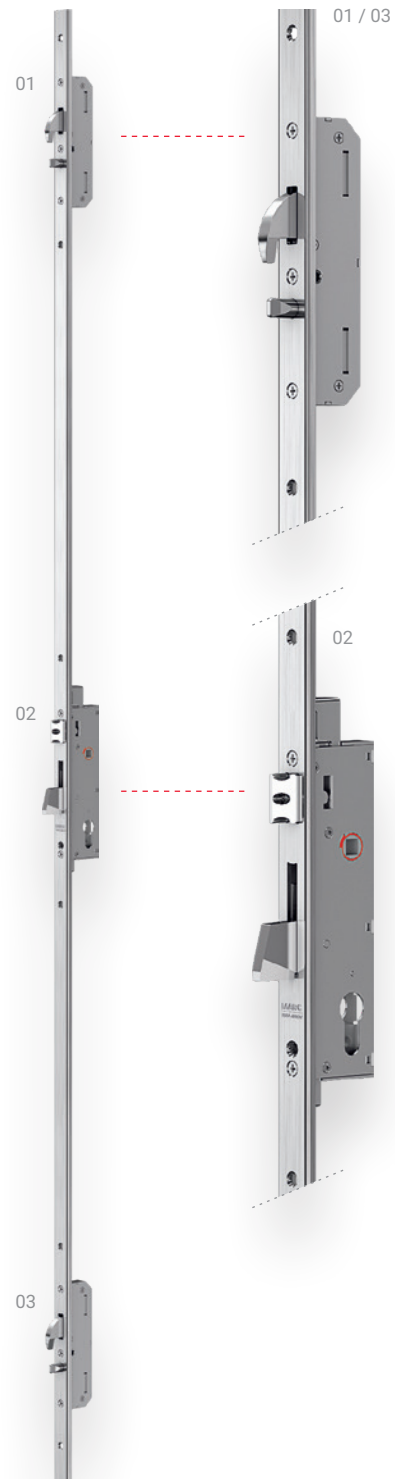
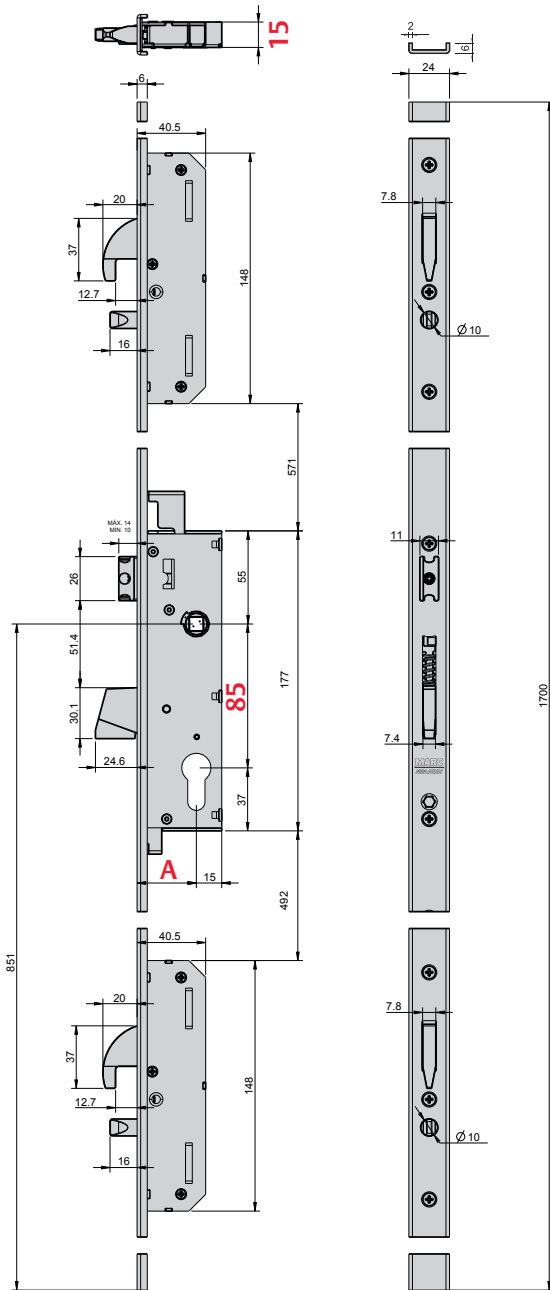

Accessório - Accessory
Accessoire - Zubehör

ROLLER KIT
Ref. R741



NORMA · STANDARD · NORME · NORM · EN12209



3 M 8 0 0 C 2 H A 2 0

Testes realizados no nosso laboratório de fábrica - Tests made in our factory lab
Testes réalisés en notre laboratoire d'usine - Im Marques-Labor geprüft und bestätigt

25	30	35
85	8	

SÉRIE 745

FTfa-745 / v.2



Accessório · Accessory
Accessoire · Zubehör

ROLLER KIT
Ref. R741



+

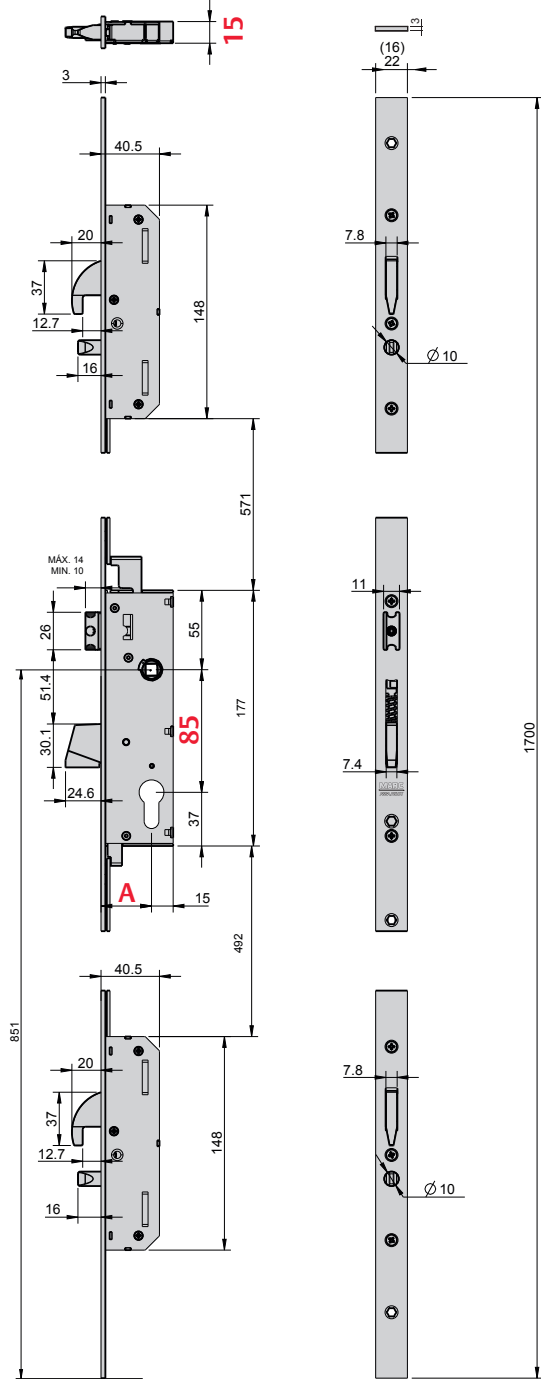
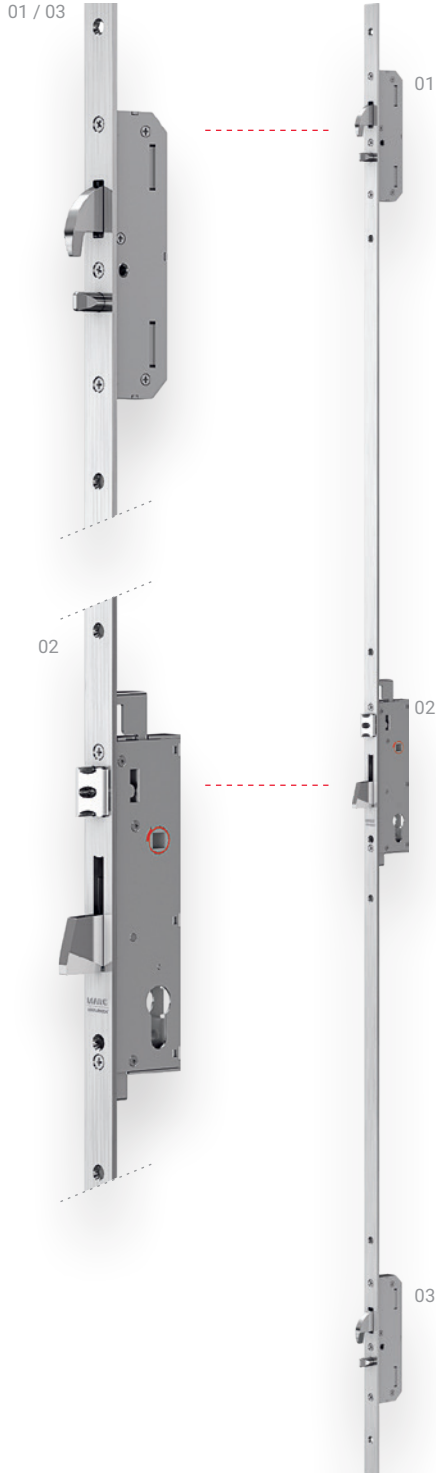

NORMA · STANDARD · NORME · NORM · EN12209



Testes realizados no nosso laboratório de fábrica · Tests made in our factory lab
Testes réalisés en notre laboratoire d'usine · Im Marques-Labor geprüft und bestätigt



SÉRIE 744

FTfa-744 / v.2



Accessório · Accessory
Accessoire · Zubehör

ROLLER KIT
Ref. R741

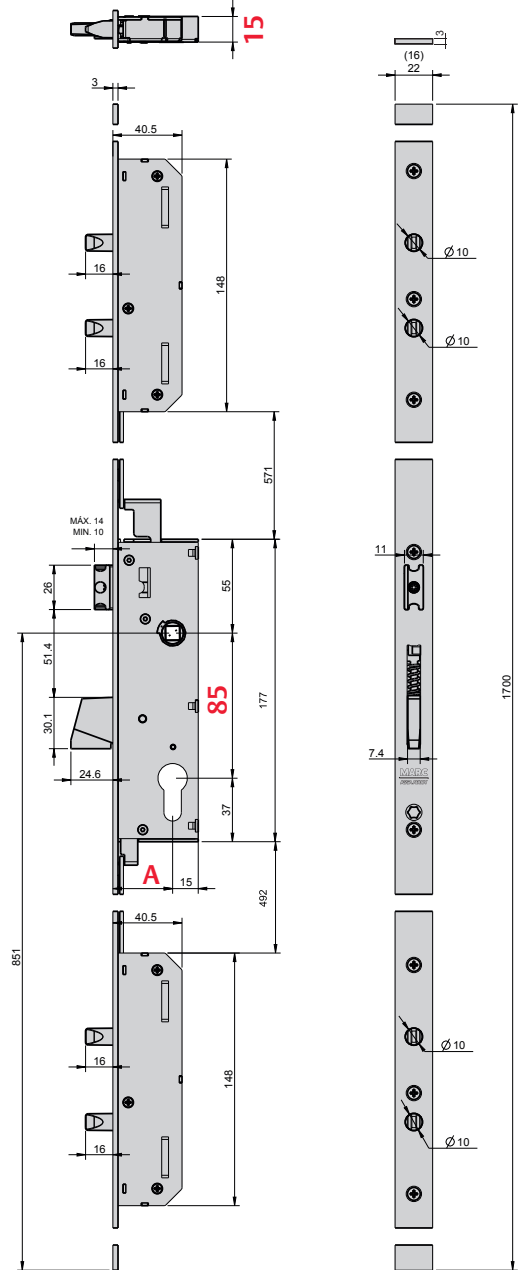
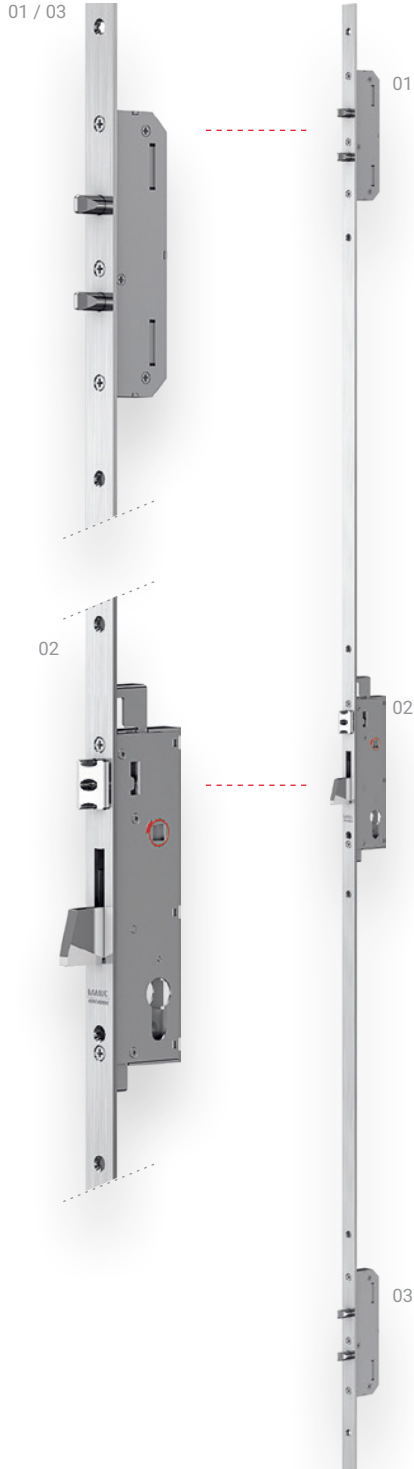

NORMA · STANDARD · NORME · NORM · EN12209



3 M 8 0 0 C 2 H A 0 0

Testes realizados no nosso laboratório de fábrica · Tests made in our factory lab
Testes réalisés en notre laboratoire d'usine · Im Marques-Labor geprüft und bestätigt

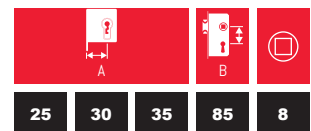

FTfa-750.85 / v.2

SÉRIE 750.85

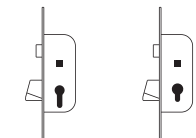
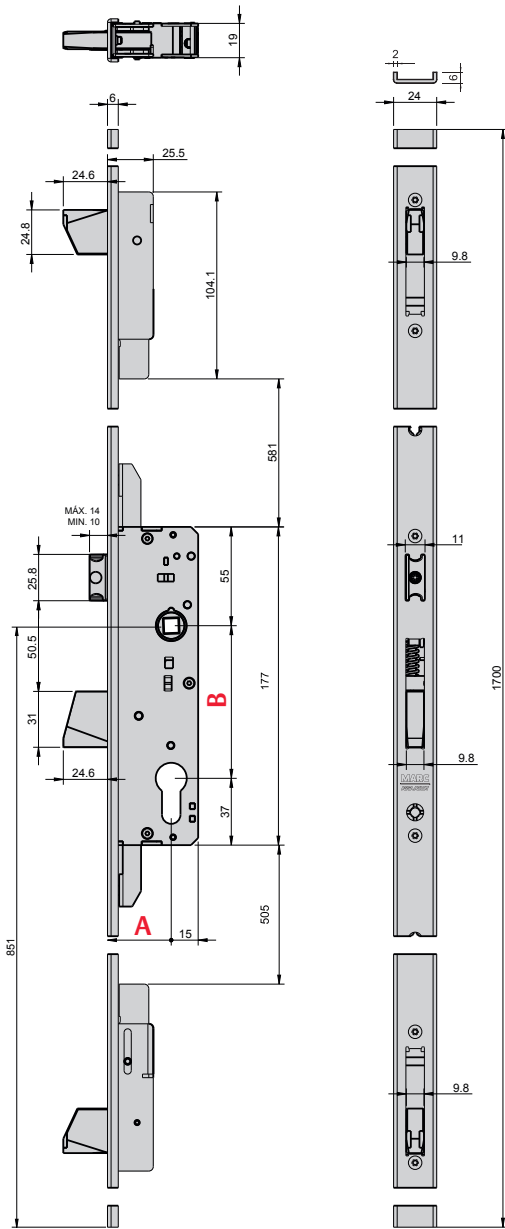

PT LB CIL (KABA)
EN LB KABA lock
FR LB Clé-I KABA
DE LB KABA-Schloss

NORMA · STANDARD · NORME · NORM · EN12209



Testes realizados no nosso laboratório de fábrica - Tests made in our factory lab
Testes réalisés en notre laboratoire d'usine - Im Marques-Labor geprüft und bestätigt

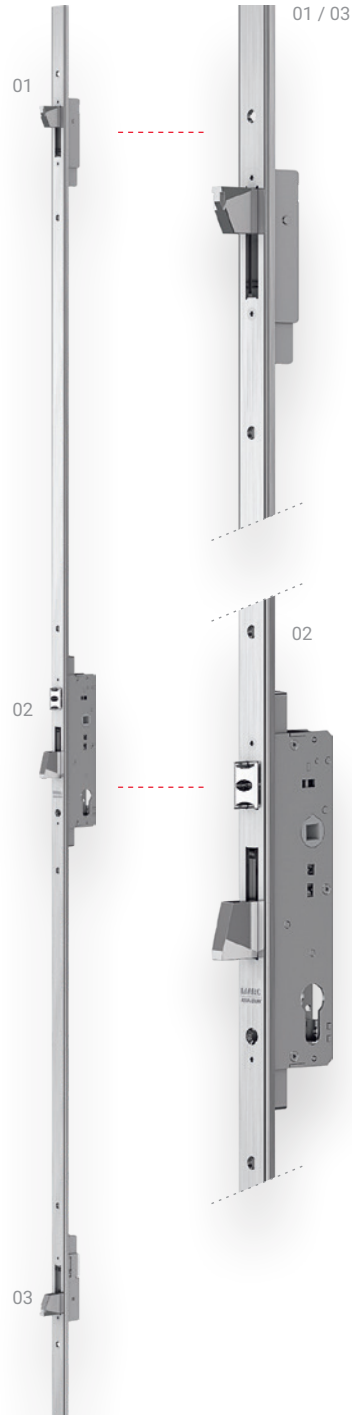

Optional - Optional
Option - Optionen



Accessório - Accessory
Accessoire - Zubehör

ROLLER KIT
Ref. R730



+



LB	25	30	35	85	8
KABA	-	30	-	87	8

SÉRIE 755.85

FTfa-755.85 / v.2



Opcional - Optional
Option - Optionen



Accessório - Accessory
Accessoire - Zubehör

ROLLER KIT
Ref. R730



+

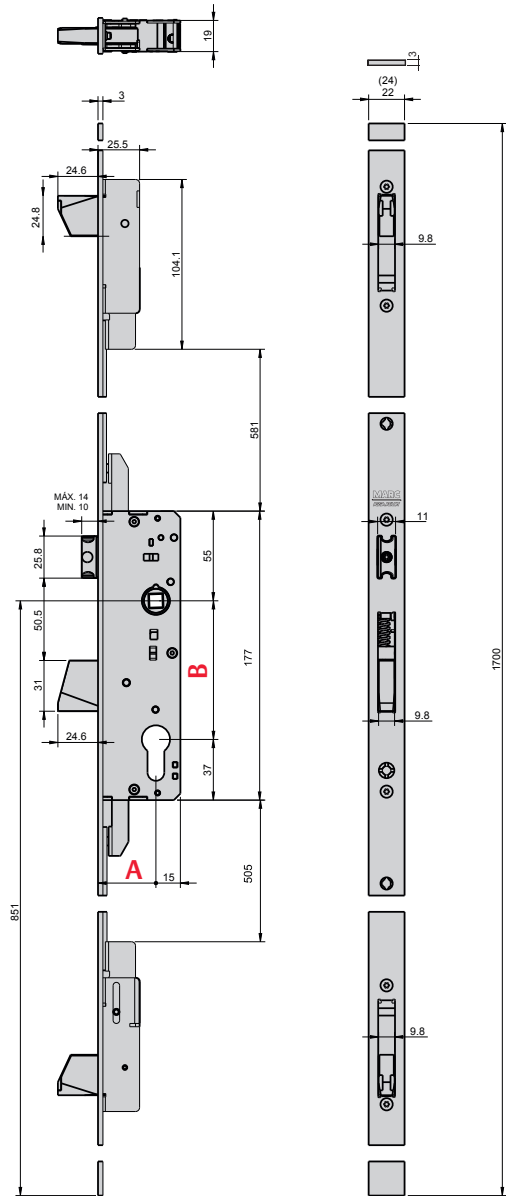
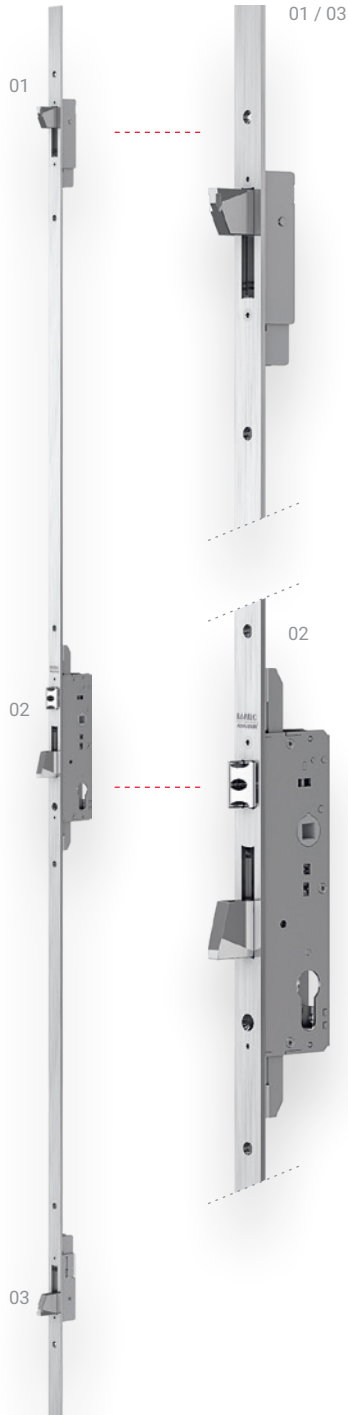

PT	LB	CIL (KABA)
EN	LB	KABA lock
FR	LB	Clé-I KABA
DE	LB	KABA-Schloss

NORMA · STANDARD · NORME · NORM · EN12209



Testes realizados no nosso laboratório de fábrica - Tests made in our factory lab
Testes réalisés en notre laboratoire d'usine - Im Marques-Labor geprüft und bestätigt

LB	25	30	35
KABA	-	30	87
			8

SÉRIE 755.92

FTfa-755.92 / v.2



Opcional · Optional
Option · Optionen



Accessório · Accessory
Accessoire · Zubehör

ROLLER KIT
Ref. R730



+



PT LB CIL (KABA)
EN LB KABA lock
FR LB Clé-I KABA
DE LB KABA-Schloss

01 / 03

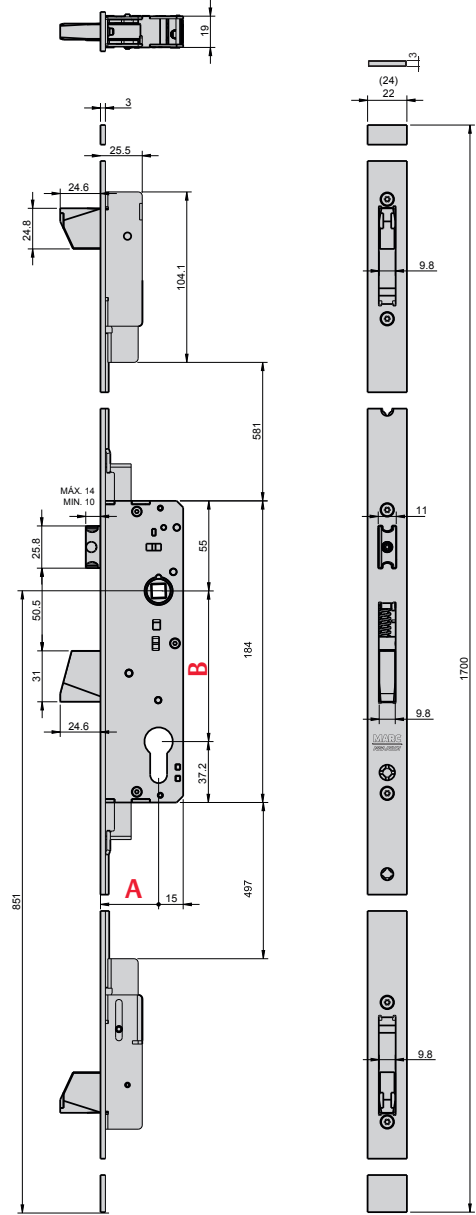
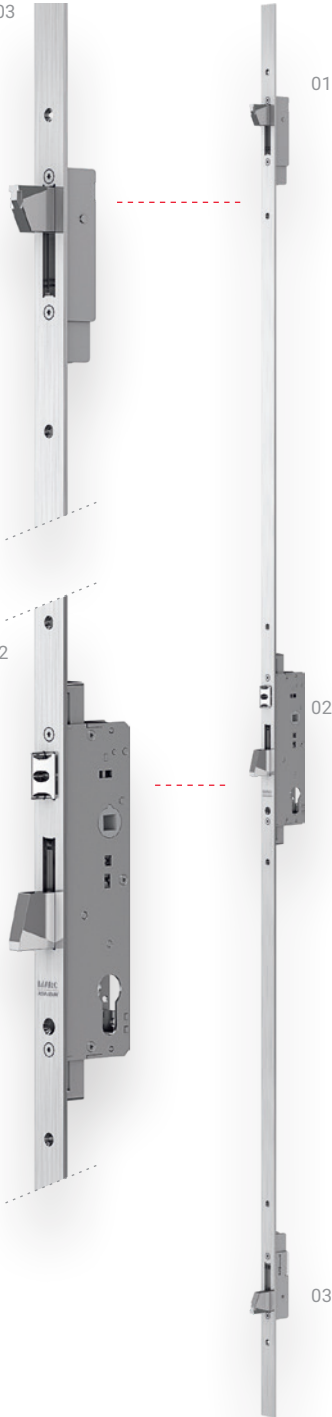

NORMA · STANDARD · NORME · NORM · EN12209



3 M 8 0 0 C 2 H A 2 0

Testes realizados no nosso laboratório de fábrica · Tests made in our factory lab
Testes réalisés en notre laboratoire d'usine · Im Marques-Labor geprüft und bestätigt

LB	25	30	35	40	92	8
KABA	25	30	35	-	94	8

FTfa-750 SEG.85 / v.2

SÉRIE 750 SEG.85

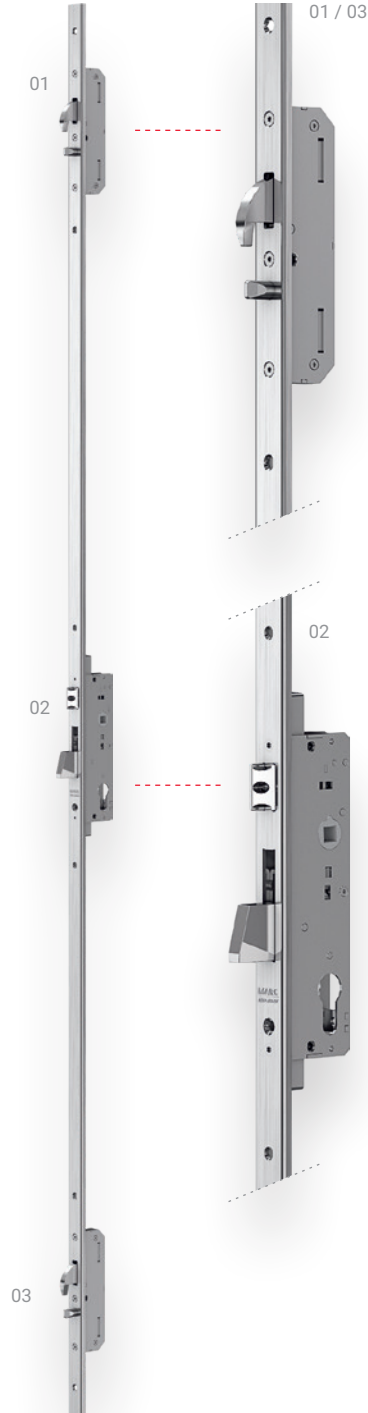
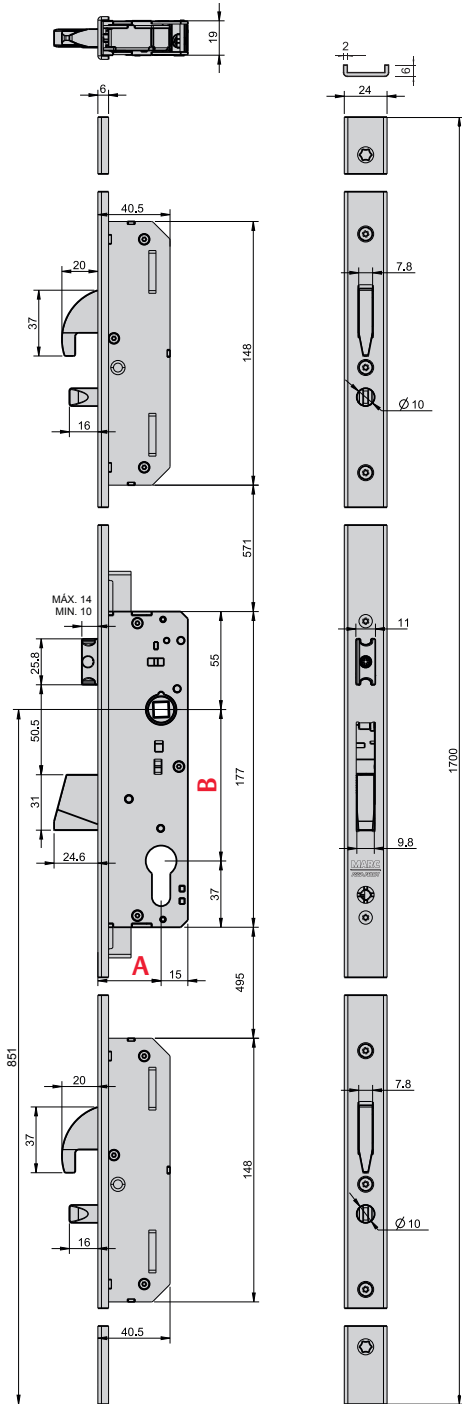

Optional - Optional
Option - Optionen

Accessório - Accessory
Accessoire - Zubehör

ROLLER KIT
Ref. R730



	PT	EN	FR	DE
LB	LB	LB	LB	LB
CIL (KABA)	KABA lock			
	Clé-1 KABA			
	KABA-Schloss			

NORMA · STANDARD · NORME · NORM · EN12209



Testes realizados no nosso laboratório de fábrica - Tests made in our factory lab
Testes réalisés en notre laboratoire d'usine - Im Marques-Labor geprüft und bestätigt

	A	B	
LB	25	30	35
KABA	-	30	-
	8	87	8

SÉRIE 755 SEG.85

FTfa-755 SEG.85 / v.2



Opcional · Optional
Option · Optionen



Accessório · Accessory
Accessoire · Zubehör

ROLLER KIT
Ref. R730



+



PT LB CIL (KABA)
EN LB KABA lock
FR LB Clé-I KABA
DE LB KABA-Schloss

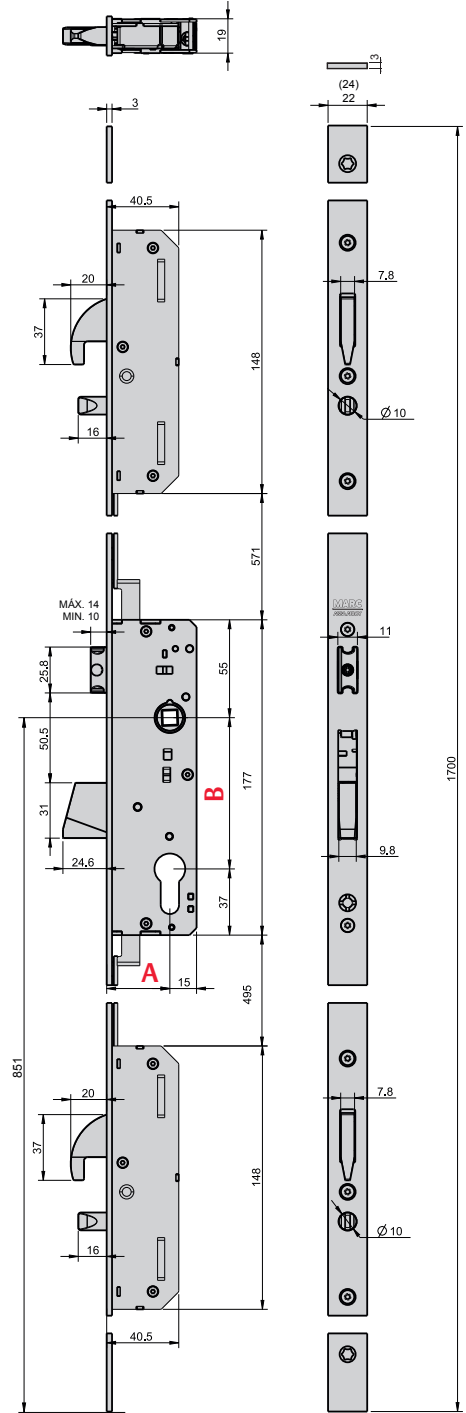
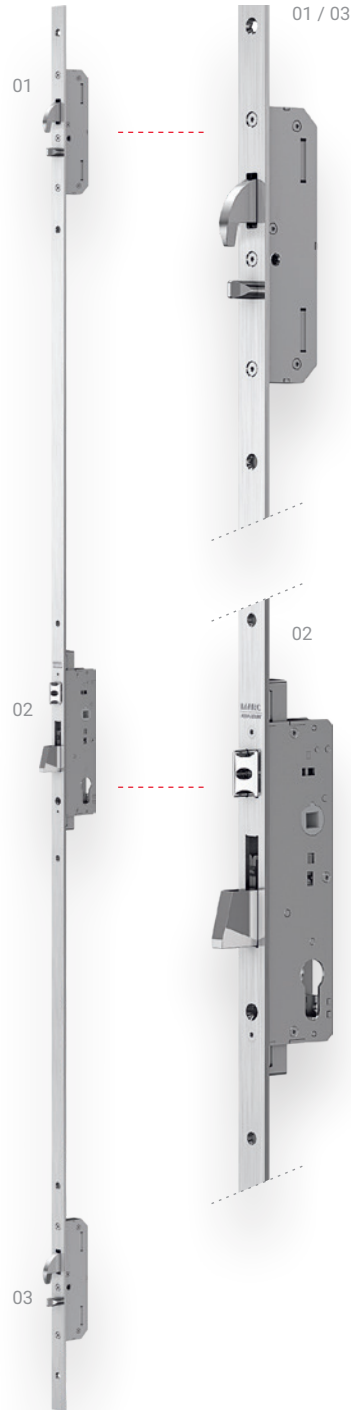

NORMA · STANDARD · NORME · NORM · EN12209



3 M 8 0 0 C 2 H A 2 0

Testes realizados no nosso laboratório de fábrica · Tests made in our factory lab
Testes réalisés en notre laboratoire d'usine · Im Marques-Labor geprüft und bestätigt

LB	25	30	35	85
KABA	-	30	-	87
				8

FTfa-750 SEG.92 / v.2

SÉRIE 750 SEG.92

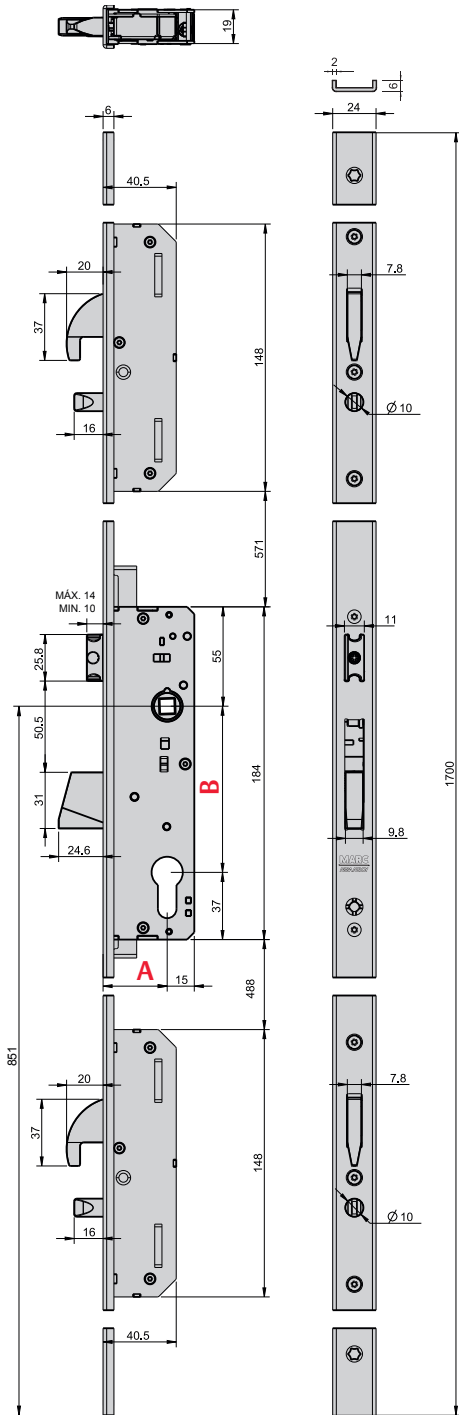

01 / 03

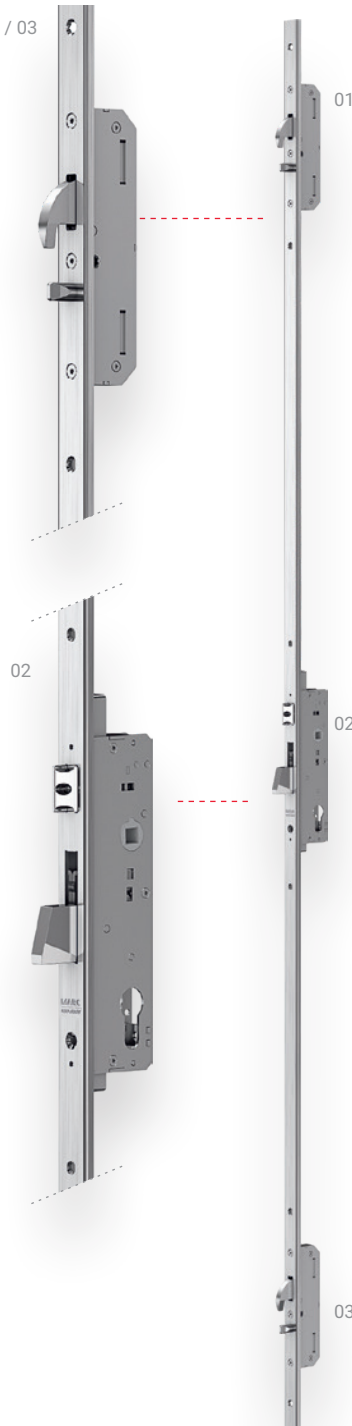

Opcional - Optional
Option - Optionen



Accessório - Accessory
Accessoire - Zubehör

ROLLER KIT
Ref. R730



+

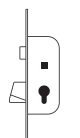
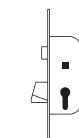

PT	LB	CIL (KABA)			
EN	LB	KABA lock			
FR	LB	Clé-I KABA			
DE	LB	KABA-Schloss			

NORMA · STANDARD · NORME · NORM · EN12209



Testes realizados no nosso laboratório de fábrica - Tests made in our factory lab
Testes réalisés en notre laboratoire d'usine - Im Marques-Labor geprüft und bestätigt

LB	25	30	35	40	92	8
KABA	25	30	35	-	94	8

SÉRIE 755 SEG.92

FTfa-755 SEG.92 / v.2



Opcional - Optional
Option - Optionen



Accessório - Accessory
Accessoire - Zubehör

ROLLER KIT
Ref. R730



+



PT LB CIL (KABA)
EN LB KABA Lock
FR LB Clé-I KABA
DE LB KABA-Schloss

01 / 03

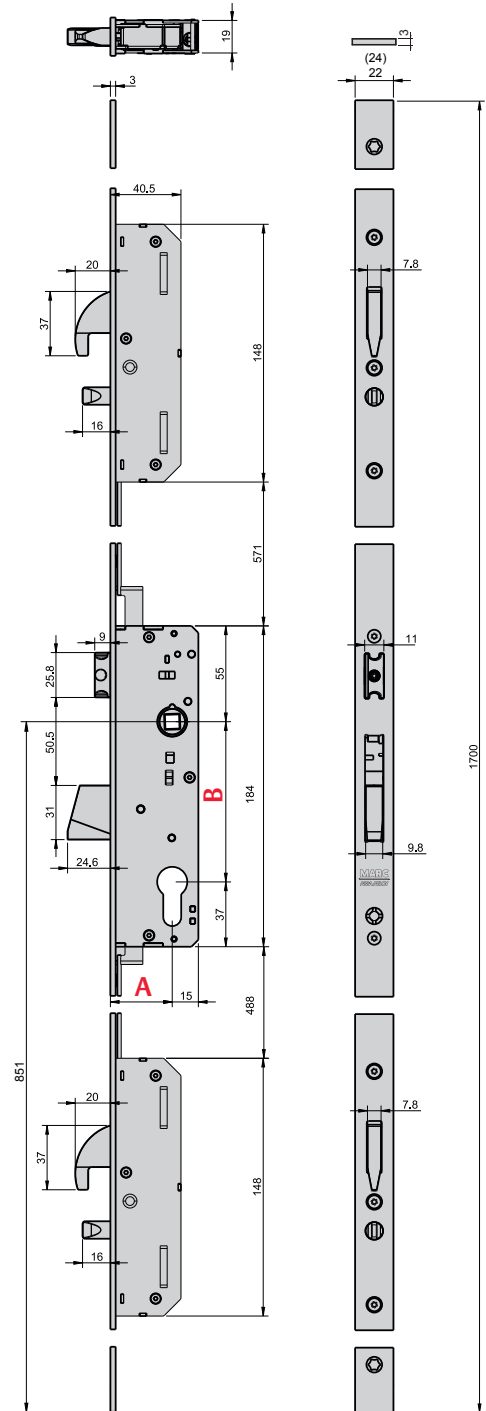
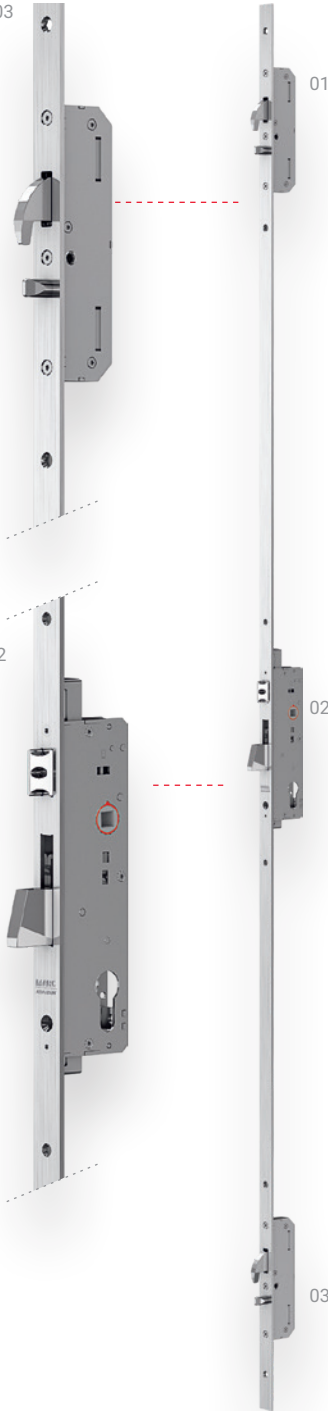

NORMA · STANDARD · NORME · NORM · EN12209



Testes realizados no nosso laboratório de fábrica - Tests made in our factory lab
Testes réalisés en notre laboratoire d'usine - Im Marques-Labor geprüft und bestätigt

LB	25	30	35	40	92	8
KABA	25	30	35	-	94	8

FTfa-735.U / v.2

SÉRIE 735-U

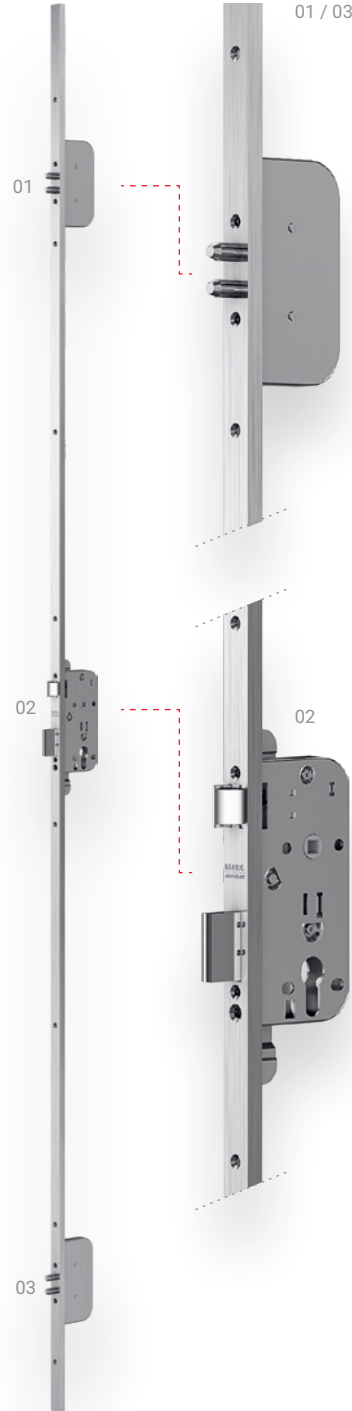
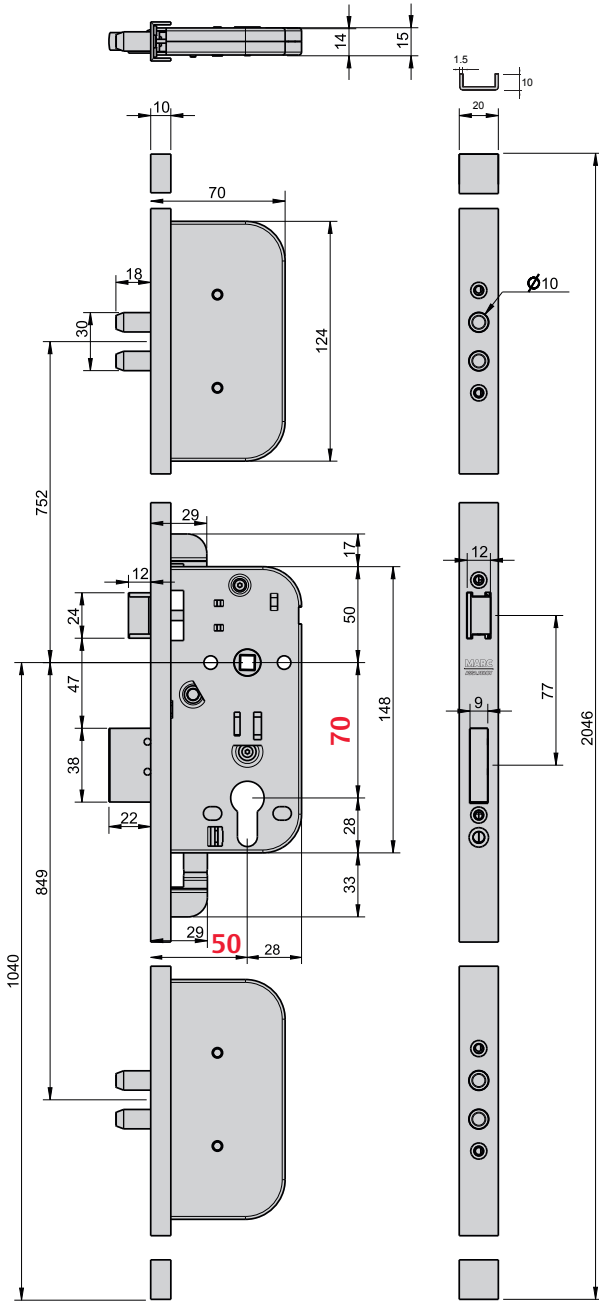

NORMA · STANDARD · NORME · NORM · EN12209



Testes realizados no nosso laboratório de fábrica - Tests made in our factory lab
Testes réalisés en notre laboratoire d'usine - Im Marques-Labor geprüft und bestätigt

A	B	
50	70	7
		8

FTfa-756 / v.2

SÉRIE 756

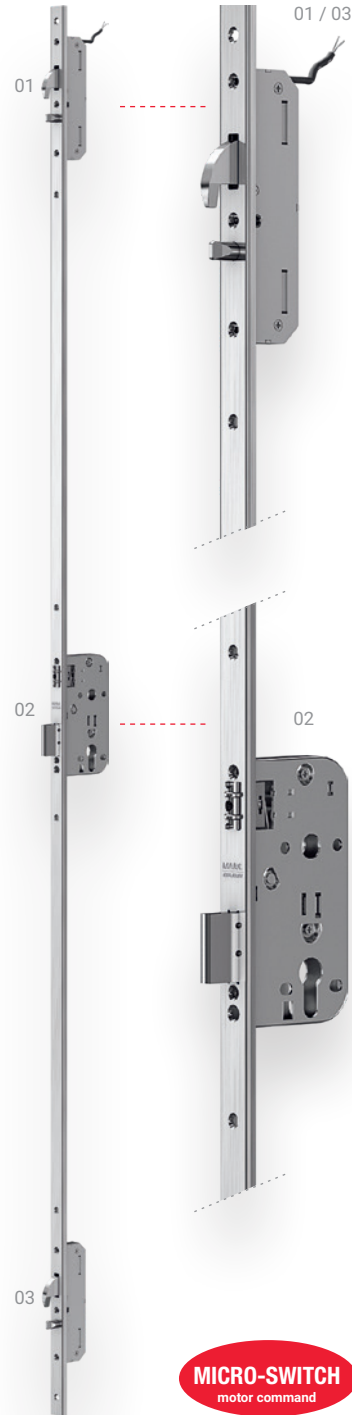
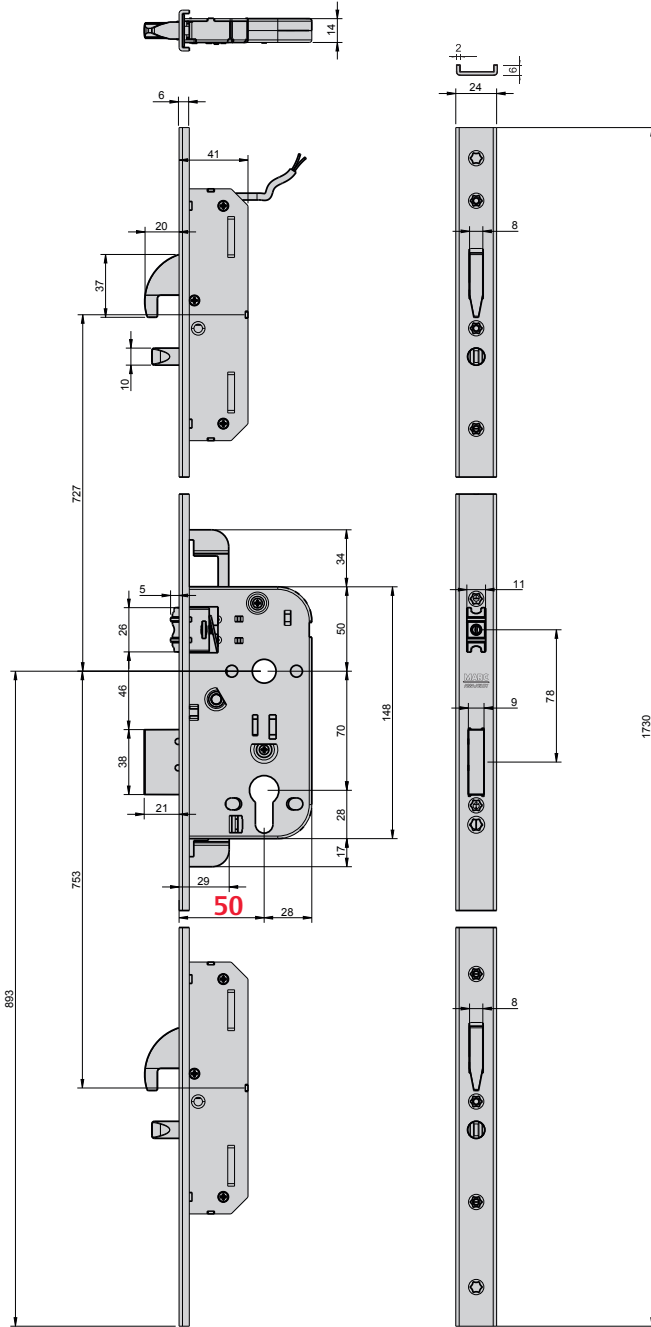

NORMA · STANDARD · NORME · NORM · EN12209



Testes realizados no nosso laboratório de fábrica · Tests made in our factory lab
Testes réalisés en notre laboratoire d'usine · Im Marques-Labor geprüft und bestätigt





Experience a safer
and more open world

 **MARC**

ASSA ABLOY



ASSA ABLOY





CILINDROS

CYLINDERS

CYLINDRES

ZYLINDER

www.mr.pt



MARC

ASSA ABLOY



DIG. 1	DIG. 2	DIG. 3	DIG. 4
Categoria de utilização Category of use Catégorie d'utilisation Einsatzbereich	Durabilidade Durability Durabilité Dauerfunktion	Massa da porta e força de fecho Door mass and closing force Masse de la porte et force de fermeture Türgewicht und Schliesskraft	Resistência ao fogo Fire resistance Resistance au feu Feuerschutz
1	4-6	-	0/A-B

1

- Utilização por pessoas muito cuidadosas apresentando um baixo risco de má utilização
- chave deve resistir a torque de 2,5 Nm e continuar utilizável
- for use by people with a high incentive to exercise care and with a small chance of misuse
- keys shall resist a torque of 2,5Nm and still be sable

4

- 25.000 ciclos
- 25.000 cycles

5

- 50.000 ciclos
- 50.000 cycles

6

- 100.000 ciclos
- 100.000 cycles

-

- sem requisito
- no requirement

0

- inapto para uso em blocos de porta resistentes ao fogo e/ou com estanquidade aos fumos
- not approved for use on fire resistant / smoke control door assemblies

A

- apto para uso em blocos de porta com estanquidade aos fumos
- suitable for use on smoke control door assemblies

B

- apto para uso em blocos de porta resistentes ao fogo e/ou com estanquidade aos fumos
- suitable for use on fire resistant smoke control door



DIG. 5	DIG. 6	DIG. 7	DIG. 8
Segurança das pessoas Safety Sécurité des personnes Die Sicherheit der Menschen	Resistência à corrosão e a temperatura Corrosion and temperature resistance Résistance à la corrosion et température Korrosionsschutz	Nível de segurança da chave key related security Sécurité des Clés Schlüsselsicherheit	Resistência a ataques Attack resistance Résistance à l'attaque Einbruchshemmung
-	0/A/B	1-6	0/A/B/C/D

-
- sem requisito
- no requirement

0
- não definido resistencia corrosão e temperatura
- no corrosion or temperature resistance requirements

A
- resistencia alta à corrosão (96h), sem requisito temperatura
- high corrosion resistance (96h), no temperature requirement

B
- resistencia corrosão não definido: temperatura extremas desde -25°C até +65 °C
- no corrosion resistance requirement: resistance -25/65°C temperature extremes

C
- resistencia alta à corrosão (96h) temperatura extremas desde -25°C até +65 °C
- high corrosion resistance (96h), -25/65°C temperature extremes

1
- 100 numero mínimo de variações efetivas
2 numero mínimo de peças de bloqueio.
- 100 Min. number of effective differs /
2 Min. number of movable detainers.

2
- 300 numero mínimo de variações efetivas
3 numero mínimo de peças de bloqueio.
- 300 Min. number of effective differs /
3 Min. number of movable detainers.

3
- 15 000 numero mínimo de variações efetivas
5 numero mínimo de peças de bloqueio.
- 15 000 Min. number of effective differs /
5 Min. number of movable detainers.

4
- 30 000 numero mínimo de variações efetivas
5 numero mínimo de peças de bloqueio.
- 30 000 Min. number of effective differs /
5 Min. number of movable detainers.

5
- 30 000 numero mínimo de variações efetivas
6 numero mínimo de peças de bloqueio.
- 30 000 Min. number of effective differs /
6 Min. number of movable detainers.

6
- 100 000 numero mínimo de variações efetivas
6 numero mínimo de peças de bloqueio.
- 100 000 Min. number of effective differs /
6 Min. number of movable detainers.

0
- nenhuma resistência à perfuração; nenhuma resistência a ataques mecânicos.
- no resistance against drilling; no resistance against mechanical attack.

A
- resistência de 3/5 min à perfuração; resistência a ataques mecânicos, exceto extração do rotor / cilindro.
- 3/5 min resistance against drilling; resistance against mechanical attack except plug/cylinder extraction.

B
- 5/10 min de resistência à perfuração; resistência a ataques mecânicos, exceto extração do rotor / cilindro.
- 5/10 min resistance against drilling; resistance against mechanical attack except plug/cylinder extraction.

C
- resistência de 3/5 min à perfuração; resistência a ataques mecânicos.
- 3/5 min resistance against drilling; resistance against mechanical attack.

D
- 5/10 min de resistência contra perfuração; resistência a ataques mecânicos.
- 5/10 min resistance against drilling; resistance against mechanical attack.

MONTAGEM E CONSELHOS DE UTILIZAÇÃO

INSTALLATION AND ADVICES OF USE

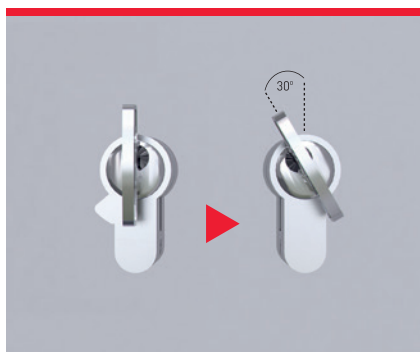

Rodar a chave até que o palhete esteja alinhado com a parte interior do cilindro.

Turn the inserted key until the lock cam is aligned with the cylinder stator.

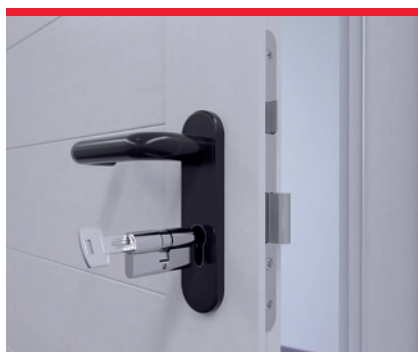

Inserir o cilindro no alojamento previsto no cofre da fechadura e/ou da porta.

Insert the cylinder into the intended compartment of the lock or door.

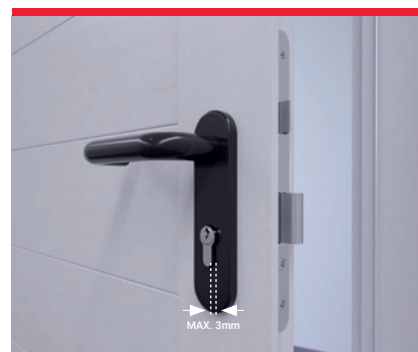

O cilindro não deve ultrapassar o espelho de proteção em mais de 3mm.

The cylinder projection must be maximum 3mm from the protective plate.

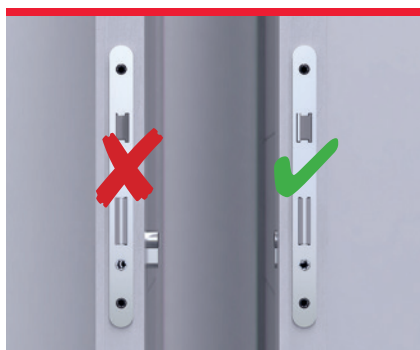

A posição do cilindro no cofre da fechadura é correta se os furos da fechadura e do cilindro estão alinhados e se o trinco e língua podem ser acionados usando a chave.

The cylinder is the correct position in the lock if the holes in the lock and cylinder are superimposed and the latch and/or deadbolt can be drawn back using the key.

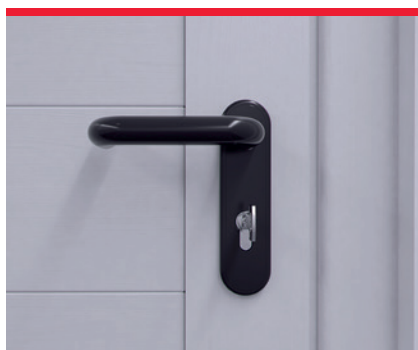

Posicionar a chave verticalmente, desde que o cilindro esteja em posição correta na fechadura.

Straighten vertically the key as soon as lock cylinder is in the right position in the lock case.



Fixar o cilindro com parafuso e apertar moderadamente sem que tal possa impedir o bom funcionamento da fechadura.

Secure the cylinder with the fixing screw and tighten moderately, without prevent the lock from working.



Não usar a força, nem ferramentas para inserir a chave.
 Don't use force (e.g. hammer) when inserting the key.



O cilindro não deve ser manipulado que com a chave correspondente. Nenhum outro instrumento deve ser utilizado.

Cylinders are only to be opened with the matching key. No other objects must be used.



A cabeça da chave não pode ser utilizada como um puxador para puxar a porta.

The key head is not a handle replacing the fitting.

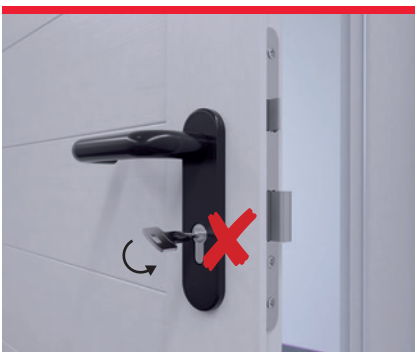

A chave deve ser totalmente inserida do cilindro antes de a manobrar.

Keys have to be inserted completely before the torque may be applied.

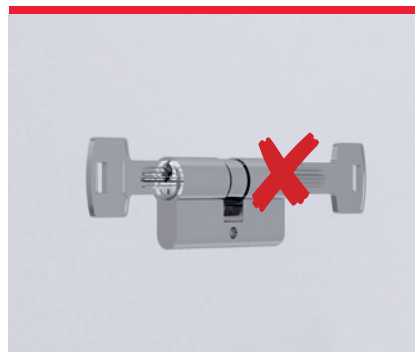

No caso de cilindros standard, não inserir as chaves dos dois lados simultaneamente.

In case of normal cylinders keys must not be put in from both sides at the same time.



Não utilizar chaves deformadas.

Bent keys must not be reused.

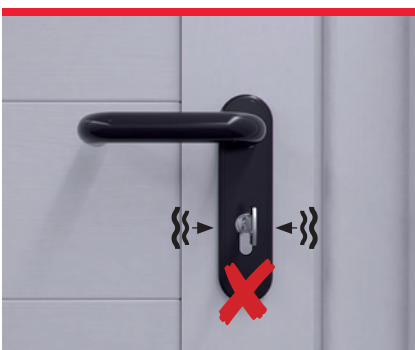

Não aplicar força lateral sobre a chave quando a introduzimos ou retiramos.

Avoid sideways force when pitting in or pulling out the key.



Os cilindros não devem ser manobrados que com as chaves originais ou reproduções autorizadas.

Lock cylinders may only be locked using original and authorised keys.

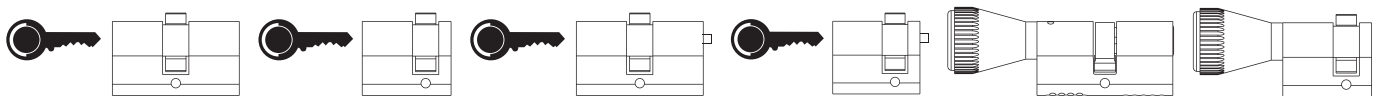
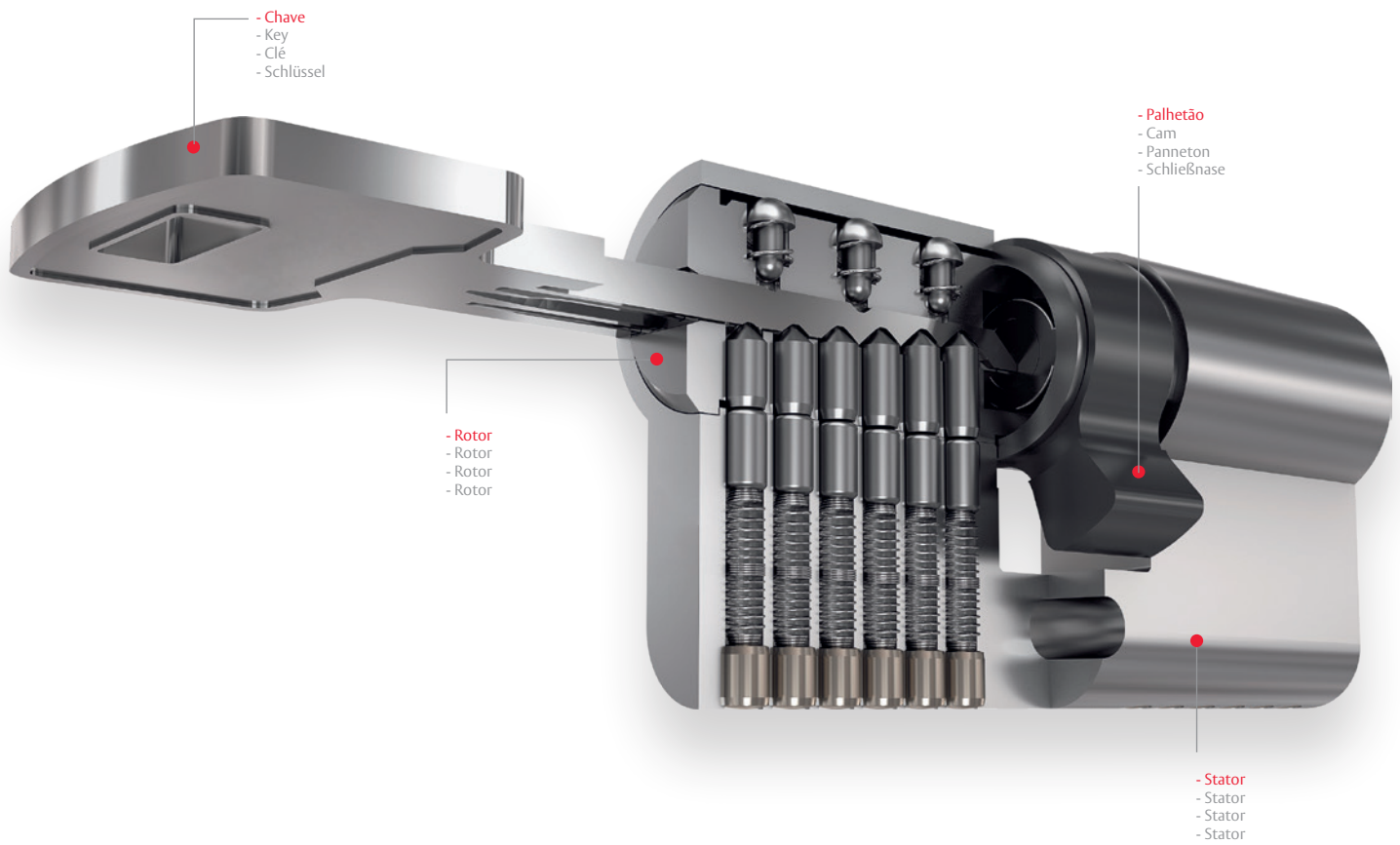

PT	C	1/2 C	C P2012	1/2 C P2012	BT	1/2 BT
EN	C	1/2 C	C P2012	1/2 C P2012	BT	1/2 BT
FR	C	1/2 C	C P2012	1/2 C P2012	BT	1/2 BT
DE	C	1/2 C	C P2012	1/2 C P2012	BT	1/2 BT



PT	T	1/2 T	WC	1/2 WC
EN	T	1/2 T	WC	1/2 WC
FR	T	1/2 T	WC	1/2 WC
DE	T	1/2 T	WC	1/2 WC

PT	UK	FR	DE
<p>Porquê uma mestragem?</p> <p>Para definir, organizar e controlar o acesso de prédios, hotéis, hospitais, escritórios, fábricas, armazéns, escolas, etc.</p>	<p>Why master key systems?</p> <p>To define, organize and control access to buildings, hotels, hospitals, offices, factories, warehouses, schools, etc.</p>	<p>Pourquoi un organigramme sur plan?</p> <p>Pour définir, organiser et contrôler l'accès aux bâtiments, hôtels, hôpitaux, bureaux, usines, entrepôts, écoles, etc.</p>	<p>Warum ein Organigramm-Plan erstellen?</p> <p>Um die Zugangsberechtigungen zu definieren, zu organisieren und zu kontrollieren. Insbesondere bei Hotels, Krankenhäusern, Bureaux, Fabriken, Lagern und Schulen ist es ratsam.</p>
Exemplos	Exemples	Exemples	Beispiele

01
SISTEMAS DE CHAVES IGUAIS
Keys alike systems
Systèmes de clés identiques (s'ouvrant)
Gleichschließende Systeme

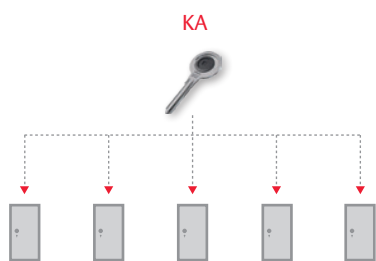

02
SISTEMAS DE ENTRADA COMUM (CILINDRO CENTRAL)
Common Entrance System (Central Cylinder)
Système D'entrée Commun (Cylindre Central)
Zentral-Zylinder-Systeme

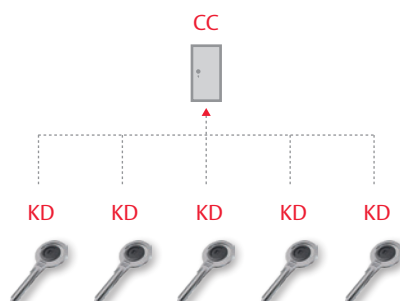

03
SISTEMA DE MESTRAGEM DE 1 NÍVEL
1 Level master key system
Système d'organigramme sur plan de 1 niveau
Organigramme auf einer Ebene

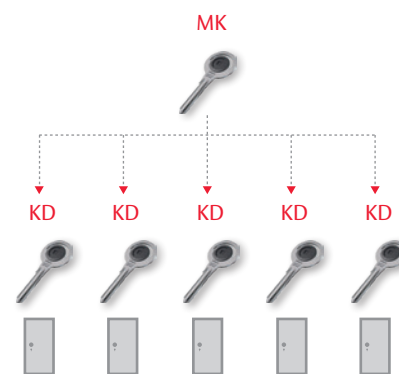

04
SISTEMAS DE MESTRAGEM DE 3 NÍVEIS
3 Levels Master Key System
Système De Organigramme Sur Plan De 3 Niveaux
Organigramme auf 3 Ebenen

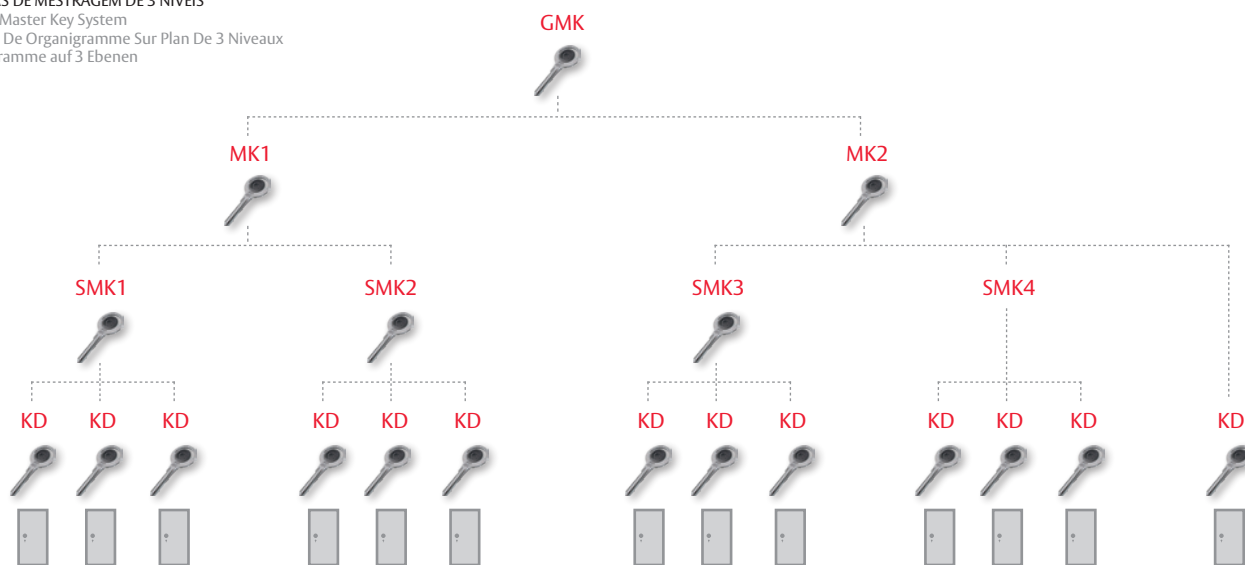

LEGENDA
Subtitle
Sous-titre
Untertitel

GMK
- Chave grande mestra
- Grand master key
- Clé grand master
- Grand Master Key

MK
- Chave mestra
- Master key
- Clé master
- Master-Key

SMK
- Chave sub mestra
- Sub master key
- Clé sub master
- Sub-Master-Key

CC
- Entrada comum
- Common entrance
- Entrée commune
- Gemeinsamer Eingang

KA
- Chaves iguais
- Keys alike
- Clés identiques
- Gleichschliessende
Schlüssel

KD
- Chaves diferentes
- Keys to differ
- Clés différentes
- Verschieden
Schließende Schlüssel

SÉRIE E500

FTcil-E500 / v.2

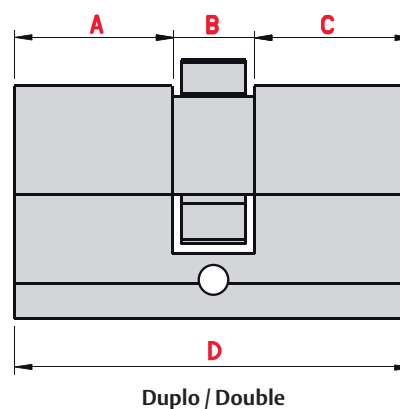
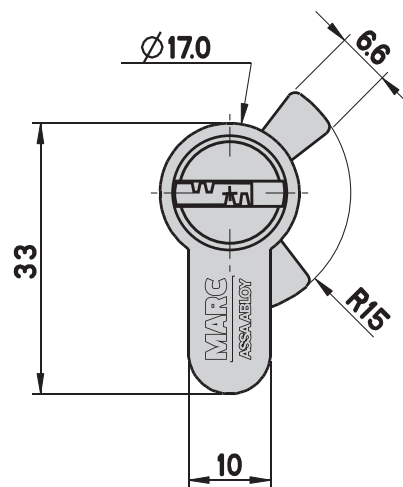

NORMA · STANDARD · NORME · NORM · EN1303



Testes realizados no nosso laboratório de fábrica · Tests made in our factory lab
Testes réalisés en notre laboratoire d'usine · Im Marques-Labor geprüft und bestätigt

	A	B	C
30/30	25	10	25
30/40	25	10	35
30/50	25	10	45
30/60	25	10	55

FTcil-E1000 / v.2

SÉRIE E1000

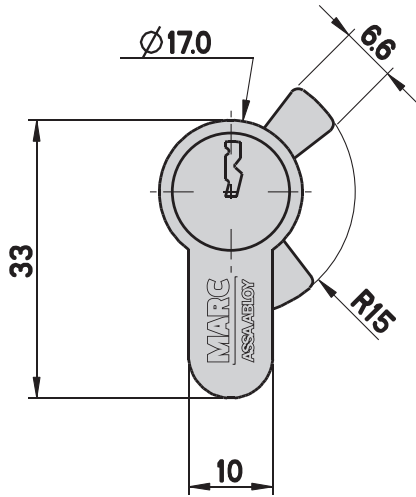

Optional - Optional
Option - Optionen

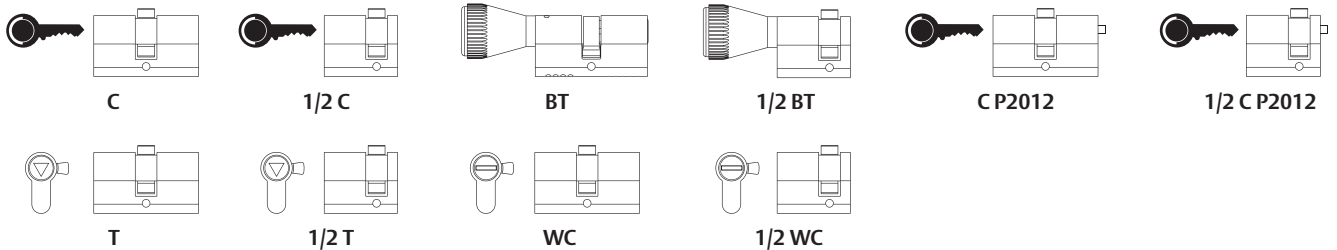
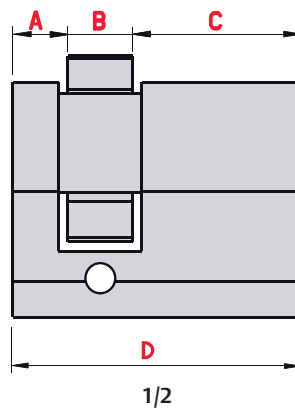
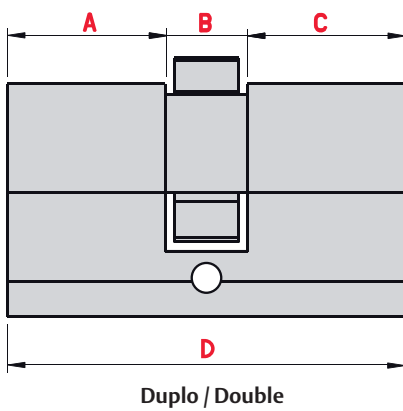

NORMA · STANDARD · NORME · NORM · EN1303



	A	B	C	D
symmetrical	25 - 55	10	25 - 55	max. 120
asymmetrical	25 - 55	10	25 - 95	max. 160
1/2 CIL	5	10	25 - 95	max. 110

Testes realizados no nosso laboratório de fábrica - Tests made in our factory lab
Testes réalisés en notre laboratoire d'usine - Im Marques-Labor geprüft und bestätigt

SÉRIE E100

-  
- 
- 
- 
- 

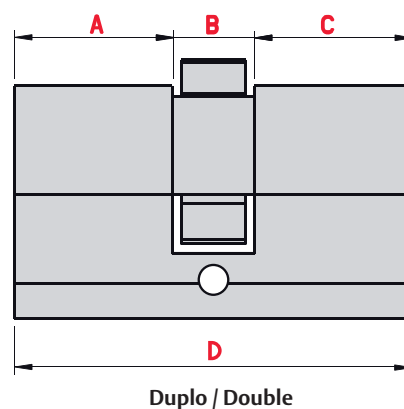
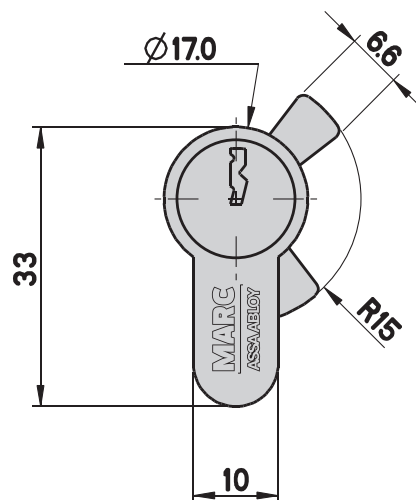

NORMA · STANDARD · NORME · NORM · EN1303



Testes realizados no nosso laboratório de fábrica - Tests made in our factory lab
Testes réalisés en notre laboratoire d'usine - Im Marques-Labor geprüft und bestätigt

	A	B	C
27,5/27,5	22,5	10	22,5
30/30	25	10	25
30/40	25	10	35
30/50	25	10	45
30/60	25	10	55

PUXADORES

Knobs · Boutons · Knöpfe

LATÃO · BRASS · LAITON · MESSING



P100

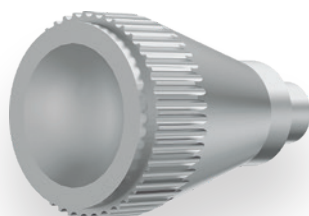

P110



P102

ZAMAK



P103



P105

ESPELHOS DE SEGURANÇA

Defender · Protecteur de Cylindre · Zylinderschutz



ESP763



ESP763 NIQ



ESP763 LAT

Together we are

A ASSA ABLOY Opening Solutions Portugal, parte do Grupo ASSA ABLOY, o líder mundial em soluções de acesso. Formado em 1994, o Grupo ASSA ABLOY está presente em mais de 70 países.

Dispomos de um vasto e completo portfólio de soluções, desde fechaduras mecânicas até aos mais recentes e inovadores sistemas de controlo de acessos. A gama de produtos ASSA ABLOY abrange molas hidráulicas, produtos de segurança para portas corta-fogo, sistemas de controlo de acessos eletromecânicos, soluções para arquitetura, dispositivos de saída antipânico e soluções de acesso mãos-livres.

Desde o início que a inovação tem definido a nossa direção e isto permite-nos ajudar milhares de milhões de pessoas a sentirem-se tranquilas, seguras e a experimentarem um mundo mais aberto.

ASSA ABLOY Opening Solutions Portugal part of the ASSA ABLOY Group, the global leader in access solutions. Formed in 1994, the ASSA ABLOY Group has grown to now cover more than 70 countries.

We offer a vast range of hardware, everything from mechanical locks to the latest innovative access control systems. The range covers door controls, fire door safety products, electromechanical access control systems, architectural hardware, panic and exit devices and hands-free solutions.

From the very beginning innovation has defined our direction and enabled us to help billions of people feel safe, secure, and experience a more open world.

Globalmente somos · Globally we are



51,000

colaboradores · employees



70+

países · countries



190+

marcas · brands



9,500

patentes · patents



2,800

colaboradores* · employees*

*dedicados à investigação & desenvolvimento
*dedicated to research & development



Os nossos valores

Our values

As ferragens para portas estão no coração da nossa atividade e temos muito orgulho nas nossas soluções, rigorosamente testadas, que abrangem tudo, desde fechaduras mecânicas até aos mais recentes sistemas de controlo de acessos.

Door hardware is at the core of our business, and we pride ourselves on our tried and tested offering, which covers everything from mechanical locks to the latest access control systems.



Segurança e prevenção de riscos · Security and loss prevention

Proteja o seu espaço para se sentir livre. Estamos dedicados em fornecer soluções de alta qualidade para a sua segurança e proteção da sua privacidade.

Secure your space to feel free. We are dedicated to delivering high-quality door solutions to protect you and your privacy.



Soluções para construção sustentável · Sustainable building solutions

Num mundo em acelerada evolução, a eficiência é tudo. Soluções rápidas e seguras de alto desempenho reduzem a utilização de energia e contribuem para um mundo mais sustentável.

In a fast moving world, efficiency is everything. Swift and secure high-performance solutions reduce energy use and make for a more sustainable world.



Design arquitetónico · Aesthetic design

Enquadre o seu espaço. O nosso objetivo é fornecer os materiais que inspirem e revitalizem os seus interiores.

Frame your space. We aim to provide hardware that will inspire and revitalise your interiors.



Segurança da vida · Life safety

A segurança em primeiro lugar. Acreditamos que os nossos produtos de segurança corta-fogo e dispositivos de saída antipânico devem demonstrar a sua conformidade através de credenciações reconhecidas de terceiros.

Safety first. We believe our fire and emergency safety products should demonstrate their compliance through recognised third-party accreditations.



Design inclusivo · Inclusive design

Certifique-se de que o seu edifício oferece acolhimento e não barreiras. Facilitar o envolvimento de todos na vida contemporânea, contribui para uma sociedade mais rica e diversa.

Ensure your building offers a welcome, not a barrier. Facilitating the involvement of everyone in contemporary life, contributes to a richer, more diverse society.

Valores e crenças essenciais · Core values and beliefs

Autonomia · Empowerment



Nós confiamos nas pessoas
We have trust in people

Inovação · Innovation



Nós temos coragem para mudar
We have the courage to change

Integridade · Integrity



Nós defendemos o que está certo
We stand for what's right

NÚMERO 2000/CEP.1295
Number

O Sistema de Gestão da Qualidade
The Quality Management System of



MARQUES, S.A.

Sede | Head Office
Zona Industrial da Alagôa
3750-301 ÁGUEDA - PORTUGAL

MR ASSA ABLOY - HARDWARE SYSTEMS, S.A.

Unidade Industrial | Industrial Unit
Raso de Travassô
3754-901 ÁGUEDA - PORTUGAL

Unidade Industrial 2 | Industrial Unit 2
Raso de Paredes
3750-316 ÁGUEDA - PORTUGAL

implementado na | implemented in the

Marques, S.A.: design, desenvolvimento, produção e comercialização de soluções / sistemas de ferragens (fechaduras, fechos, cilindros e controlo de acesso);
MR Assa Abloy - Hardware Systems, S.A.: design, desenvolvimento, produção e comercialização de acessórios para soluções / sistemas de alumínio e PVC,

*Marques, S.A.: design, development, production and commercialization of building hardware solutions / systems (locks, closures, cylinders and access control);
MR Assa Abloy - Hardware Systems, S.A.: design, development, production and commercialization of accessories for aluminum and PVC solutions/ systems, meets the requirements of the standard.*

cumpre os requisitos da norma | meets the requirements of the standard

NP EN ISO 9001:2015



Emitido em 2022-09-30
Date of issue
Válido até 2023-07-10
Valid until

José Leitão
CEO

APCER - Associação Portuguesa de Certificação
o/Porto Bessa Leite Complex | Rua António Bessa Leite, 1430 - 1.º Esq.
4150-014 Porto
www.apcergroup.com



THE INTERNATIONAL CERTIFICATION NETWORK

CERTIFICATE

APCER has issued an IQNet recognized certificate that
the organization

MARQUES, S.A.
Head Office

Zona Industrial da Alagôa
3750-301 ÁGUEDA - PORTUGAL

MR ASSA ABLOY - HARDWARE SYSTEMS, S.A.

Industrial Unit
Raso de Travassô
3754-901 ÁGUEDA - PORTUGAL

Industrial Unit 2
Raso de Paredes
3750-316 ÁGUEDA - PORTUGAL

has implemented and maintains a

Quality Management System

for the following scope:

Marques, S.A.: design, development, production and commercialization of building hardware solutions / systems (Locks, Closures, Cylinders and Access Control)

MR Assa Abloy - Hardware Systems, S.A.: design, development, production and commercialization of accessories for aluminum and PVC solutions/ systems

which fulfils the requirements of the following standard

ISO 9001:2015

Issued on: 2022-09-30
Expires on: 2023-07-10

This attestation is directly linked to the IQNet Partner's original certificate and shall not be used as a stand-alone document

Registration Number: PT- 2000/CEP.1295



Alex Stoichitoiu
President of IQNet

José Leitão
APCER CEO



IQNet Partners*:

AENOR Spain AFNOR Certification France APCER Portugal CCC Cyprus CISQ Italy
CQC China CQM China CQS Czech Republic Cro Cert Croatia DQS Holding GmbH Germany ENGL Certification Group USA
FCV Brazil FONDOPOROMA Venezuela ICONTEC Colombia Inspecta Serbisanti Oy Finland INTECO Costa Rica
IRAM Argentina JQA Japan KFQ Korea MIRTEC Greece MSZT Hungary Nemko AS Norway NSAI Ireland
NYCE-SIGE Mexico PCBC Poland Quality Austria Austria RR Russia SII Israel SIQ Slovenia
SIRIM QAS International Malaysia SQS Switzerland SRAC Romania TEST St Petersburg Russia TSE Turkey YUQS Serbia

* The list of IQNet partners is valid at the time of issue of this certificate. Updated information is available under www.iqnet-certification.com

Experience a safer
and more open world



ASSA ABLOY Opening Solutions

MR ASSA ABLOY
Raso de Travassô - Apartado 3147
3754-901 Águeda - Portugal

Tel + 351 234 630 440
mr@assaabloy.com
www.mr.pt



Eficiência
Energética

